

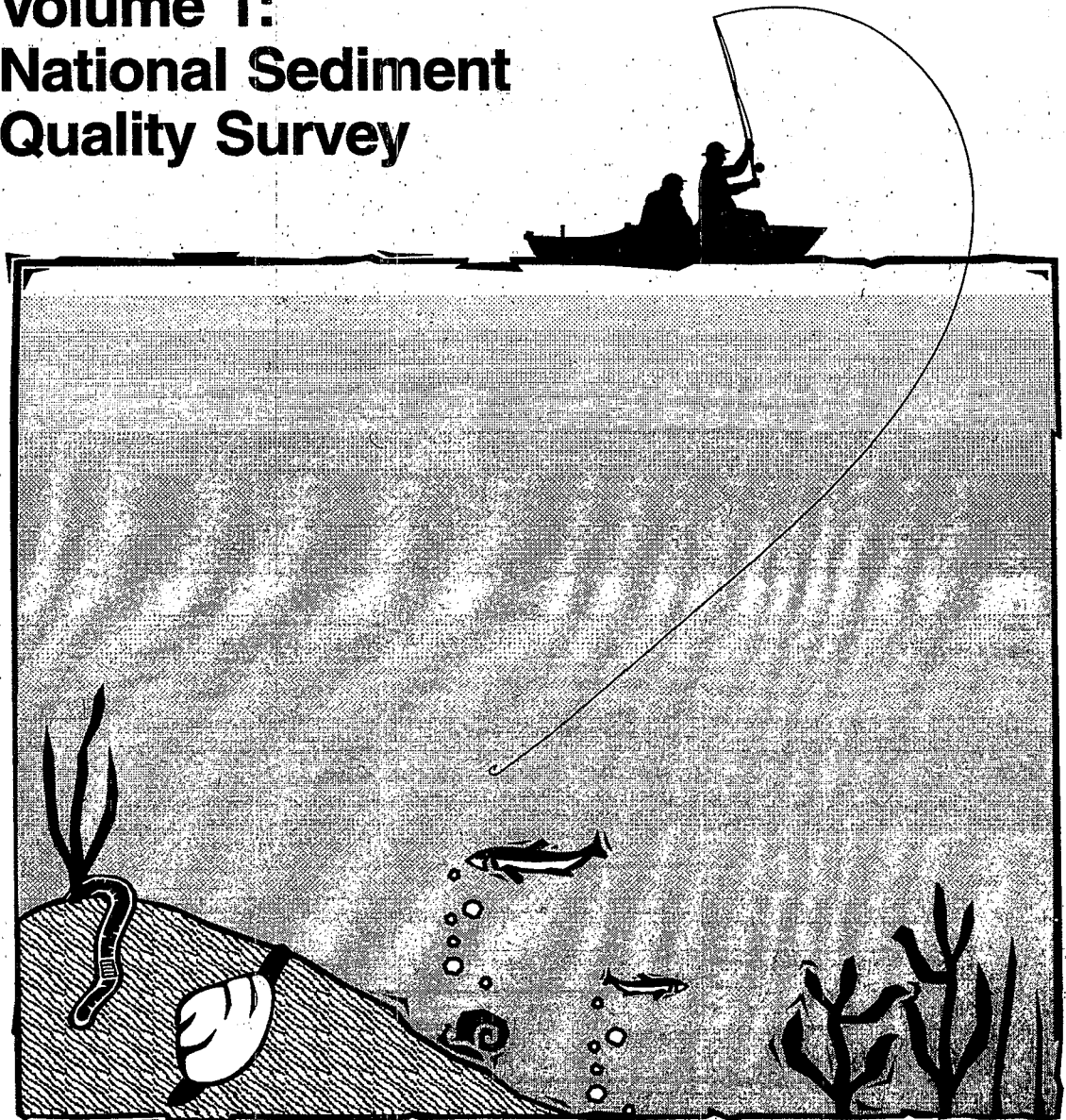

The Incidence And Severity Of Sediment Contamination In Surface Waters Of The United States

Volume 1: National Sediment Quality Survey

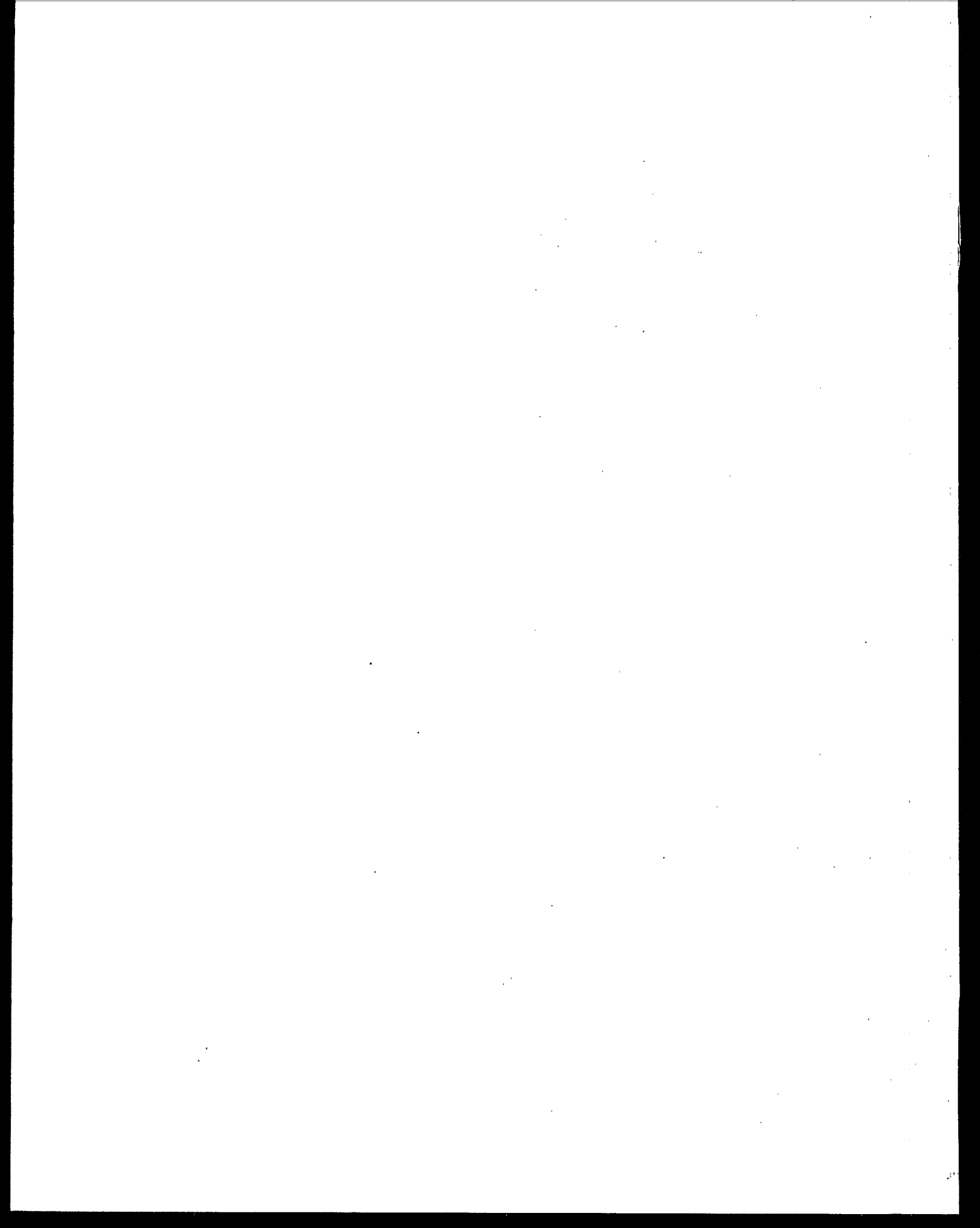





UNITED STATES ENVIRONMENTAL PROTECTION AGENCY
WASHINGTON, D.C. 20460

JAN 7 1997

THE ADMINISTRATOR

The Honorable Albert Gore, Jr.
President of the Senate
Washington, D.C. 20510

Dear Mr. President:

As required by the Water Resources Development Act of 1992 (WRDA), I am pleased to transmit the Environmental Protection Agency's (EPA) Report to Congress on the Incidence and Severity of Sediment Contamination in Surface Waters of the United States. This report describes the accumulation of chemical contaminants in river, lake, ocean, and estuary bottoms and includes a screening assessment of the potential for associated adverse effects to human and environmental health. It represents the first comprehensive EPA analysis of sediment chemistry and related biological data to assess what is known about the national incidence and severity of sediment contamination. As directed by WRDA, EPA consulted with the U.S. Army Corps of Engineers and the National Oceanic and Atmospheric Administration in compiling data and preparing the report.

EPA studied available data from sixty-five percent of the 2,111 watersheds in the continental United States and identified ninety-six watersheds that contain "areas of probable concern." In portions of these watersheds, environmental conditions may be unsuitable for bottom dwelling creatures, and fish that live in these waters may contain chemicals at levels unsafe for regular consumption. Areas of probable concern are located in regions affected by urban and agricultural runoff, municipal and industrial waste discharge, and other pollution sources. EPA recommends that resource managers fully examine the risks to human health and the environment in these watersheds. Authorities should take steps to ensure that major pollution sources are effectively controlled and that plans are in place to improve sediment conditions and to support long-term health goals. EPA's goals for managing the problem of contaminated sediment are provided as an enclosure to this letter.



Printed on Recycled Paper

The process to produce EPA's Report to Congress on the Incidence and Severity of Sediment Contamination in Surface Waters of the United States has been thorough and extensive, meeting WRDA requirements for Federal agency consultation, as well as EPA's own standards and policies regarding internal program and regional office review, external scientific peer review, and external stakeholder review. I would be pleased to further discuss the contents of this report at your convenience.

Sincerely,

A handwritten signature in cursive script, reading "Carol M. Browner". The signature is written in black ink and is positioned centrally on the page, below the word "Sincerely,".

Carol M. Browner

Enclosure



UNITED STATES ENVIRONMENTAL PROTECTION AGENCY
WASHINGTON, D.C. 20460

JAN 7 1997

THE ADMINISTRATOR

The Honorable Newt Gingrich
Speaker of the House of Representatives
Washington, D.C. 20515

Dear Mr. Speaker:

As required by the Water Resources Development Act of 1992 (WRDA), I am pleased to transmit the Environmental Protection Agency's (EPA) Report to Congress on the Incidence and Severity of Sediment Contamination in Surface Waters of the United States. This report describes the accumulation of chemical contaminants in river, lake, ocean, and estuary bottoms and includes a screening assessment of the potential for associated adverse effects to human and environmental health. It represents the first comprehensive EPA analysis of sediment chemistry and related biological data to assess what is known about the national incidence and severity of sediment contamination. As directed by WRDA, EPA consulted with the U.S. Army Corps of Engineers and the National Oceanic and Atmospheric Administration in compiling data and preparing the report.

EPA studied available data from sixty-five percent of the 2,111 watersheds in the continental United States and identified ninety-six watersheds that contain "areas of probable concern." In portions of these watersheds, environmental conditions may be unsuitable for bottom dwelling creatures, and fish that live in these waters may contain chemicals at levels unsafe for regular consumption. Areas of probable concern are located in regions affected by urban and agricultural runoff, municipal and industrial waste discharge, and other pollution sources. EPA recommends that resource managers fully examine the risks to human health and the environment in these watersheds. Authorities should take steps to ensure that major pollution sources are effectively controlled and that plans are in place to improve sediment conditions and to support long-term health goals. EPA's goals for managing the problem of contaminated sediment are provided as an enclosure to this letter.



Printed on Recycled Paper

The process to produce EPA's Report to Congress on the Incidence and Severity of Sediment Contamination in Surface Waters of the United States has been thorough and extensive, meeting WRDA requirements for Federal agency consultation, as well as EPA's own standards and policies regarding internal program and regional office review, external scientific peer review, and external stakeholder review. I would be pleased to further discuss the contents of this report at your convenience.

Sincerely,

A handwritten signature in black ink, appearing to read "Carol M. Browner". The signature is fluid and cursive, with the first name "Carol" being the most prominent.

Carol M. Browner

Enclosure

Managing Contaminated Sediment in the United States

Issue Background

Many pollutants released to the environment settle and accumulate in the silt and mud called sediment on the bottoms of rivers, lakes, estuaries, and oceans. Much of the contaminated sediment in the U.S. was polluted years ago by such chemicals as DDT, PCBs, and mercury, which have since been banned or restricted. These contaminants are now found less frequently in overlying surface water than in the past. However, they can persist for many years in the sediment, where they can cause adverse effects to aquatic organisms and to human health. Some other chemicals released to surface waters from industrial and municipal discharges, and polluted runoff from urban and agricultural areas, continue to accumulate to environmentally harmful levels in sediment.

Costs of Sediment Contamination

Ecological and human health impairment due to contaminated sediment imposes costs on society. Fish diseases causing tumors and fin rot and loss of species and communities that cannot tolerate sediment contamination can severely damage aquatic ecosystems. Contaminants in sediment can also poison the food chain. Fish and shellfish can become unsafe for human or wildlife consumption. Potential costs to society include lost recreational enjoyment and revenues or, worse, possible long-term adverse health effects such as cancer or children's neurological and IQ impairment if fish consumption warnings are not issued and heeded. The health and ecological risks posed by contaminated sediment dredged from harbors can lead to increased cost of disposal and lost opportunities for beneficial uses, such as habitat restoration.

Volume of Contaminated Sediments

The U.S. Environmental Protection Agency estimates that approximately 10 percent of the sediment underlying our nation's surface water is sufficiently contaminated with toxic pollutants to pose potential risks to fish and to humans and wildlife who eat fish. This represents about 1.2 billion cubic yards of contaminated sediment out of the approximately 12 billion cubic yards of total surface sediments (upper five centimeters) where many bottom dwelling organisms live, and where the primary exchange processes between the sediment and overlying surface water occur. Approximately 300 million

cubic yards of sediments are dredged from harbors and shipping channels annually to maintain commerce, and about 3-12 million cubic yards of those are sufficiently contaminated to require special handling and disposal. These amounts are graphically illustrated in the diagram below.

Volume of U.S. Sediment by Category

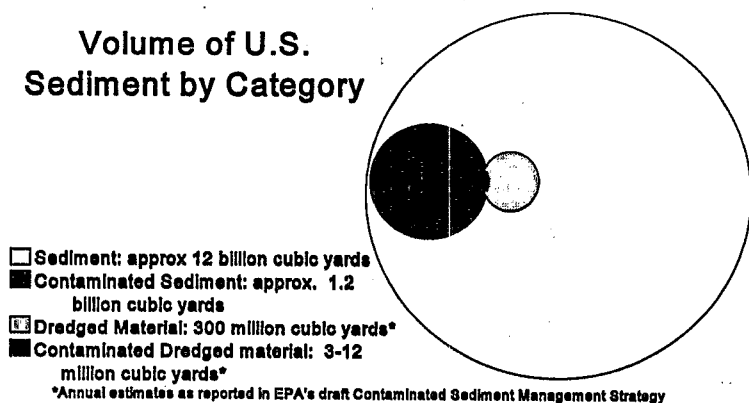

Where is contaminated sediment a potential concern?

EPA has studied data from 1,372 of the 2,111 watersheds in the continental U.S. Of these, EPA has identified 96 watersheds that contain "areas of probable concern" where potential adverse effects of sediment contamination are more likely to be found. These areas, identified in the figure below, are on the Atlantic, Gulf, Great Lakes, and Pacific coasts, as well as in inland waterways, in regions affected by urban and agricultural runoff, municipal and industrial waste discharges, and other pollution sources. Some of these areas have been studied extensively, and now have appropriate management actions in place. However, others may require further evaluation to confirm that environmental effects are occurring.

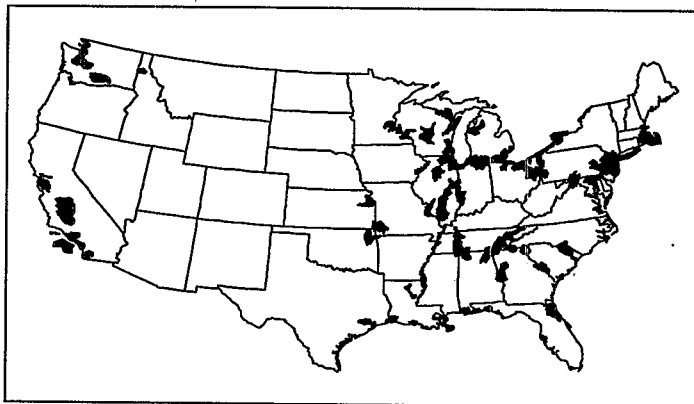

EPA's Contaminated Sediment Goals

EPA's Contaminated Sediment Management Strategy establishes four goals to manage the problem of contaminated sediment, and describes actions the Agency intends to take to accomplish those goals. The four goals are:

- 1. Prevent the volume of contaminated sediment from increasing.** To accomplish this, EPA will employ its pollution prevention and source control programs. Both the pesticides and toxic substances programs will use new and existing chemical registration programs to reduce the potential for release of sediment contaminants to surface waters. The water program will work with States and Tribes to identify waterbodies with contaminated sediment as impaired and target them for Total Maximum Daily Load evaluations. EPA will also work with the States and Tribes to enhance the implementation of point and nonpoint source controls in these watersheds.
- 2. Reduce the volume of existing contaminated sediment.** EPA will consider a range of risk management alternatives to reduce the volume and effects of existing contaminated sediment, including in-situ containment and contaminated sediment removal. In some cases, risk managers may select a combination of practicable alternatives as the remedy. Where natural attenuation is part of the selected alternative, EPA will accelerate pollution prevention and source control efforts, where appropriate, to ensure that clean sediments will bury contaminated ones within an acceptable recovery period. During the recovery period, EPA will work with the States to improve human health protection by establishing and maintaining appropriate fish consumption advisories. In all cases, environmental monitoring will be conducted to ensure that risk management goals are achieved.
- 3. Ensure that sediment dredging and dredged material disposal are managed in an environmentally sound manner.** EPA carefully evaluates the potential environmental effects of proposed dredged material disposal. In addition, EPA is initiating a national stakeholder review process to help the Agency review the ocean disposal testing requirements and ensure that any future revisions reflect both sound policy and sound science. EPA and the Army Corps of Engineers also will provide appropriate guidance to further encourage and promote beneficial uses of dredged material.

4. Develop scientifically sound sediment management tools for use in pollution prevention, source control, remediation, and dredged material management. Such tools include national inventories of sediment quality and environmental releases of contaminants, numerical assessment guidelines to evaluate contaminant concentrations, and standardized bioassay tests to evaluate the bioaccumulation and toxicity potential of specific sediment samples.

Working with States and Tribes through existing statutory authorities, EPA can identify impaired waterbodies and watersheds at risk from contaminated sediment, implement appropriate actions to accomplish the goals described above, and monitor the effectiveness of actions taken to accomplish the Agency's goals.

The Incidence And Severity Of Sediment Contamination In Surface Waters Of The United States:

Volume 1: National Sediment Quality Survey

September 1997

Office of Science and Technology
United States Environmental Protection Agency
401 M Street, SW
Washington, DC 20460

The *National Sediment Quality Survey* is a screening-level assessment of sediment quality that compiles and evaluates sediment chemistry data and related biological data taken from existing databases. The data and information contained in this document could be used in various EPA regulatory programs for priority setting or other purposes after further evaluation for program-specific criteria. However, this document has no immediate or direct regulatory consequence. It does not in itself establish any legally binding requirements, establish or affect legal rights or obligations, or represent a determination of any party's liability.

Contents

	<i>Page</i>
Tables	v
Figures	ix
Acknowledgments	xiii
Executive Summary	xv
1 Introduction	1-1
What Is the National Sediment Quality Survey?	1-1
Why Is Contaminated Sediment an Important National Issue?	1-2
How Significant is the Problem?	1-3
What Are the Potential Sources of Sediment Contamination?	1-4
2 Methodology	2-1
Background	2-2
Description of NSI Data	2-3
NSI Data Evaluation Approach	2-4
Sediment Chemistry Data	2-12
Tissue Residue Data	2-15
Toxicity Data	2-15
Incorporation of Regional Comments on the Preliminary Evaluation of Sediment Chemistry Data	2-16
Evaluation Using EPA Wildlife Criteria	2-16
3 Findings	3-1
National Assessment	3-1
Watershed Analysis	3-12
Wildlife Assessment	3-17
Regional and State Assessment	3-17
EPA Region 1	3-22
EPA Region 2	3-27
EPA Region 3	3-32
EPA Region 4	3-37
EPA Region 5	3-43
EPA Region 6	3-49
EPA Region 7	3-54
EPA Region 8	3-59
EPA Region 9	3-63
EPA Region 10	3-68
Potentially Highly Contaminated Sites Not Identified by the NSI Evaluation	3-73

Contents (continued)

4	Pollutant Sources	4-1
	Extent of Sediment Contamination by Chemical Class	4-2
	Major Sediment Contaminant Source Categories	4-3
	Land Use Patterns and Sediment Contamination	4-8
	EPA's Point and Nonpoint Source Sediment Contaminant Inventories	4-14
5	Conclusions and Discussion	5-1
	Extent of Sediment Contamination	5-2
	Sources of Sediment Contamination	5-4
	Comparison of NSI Evaluation Results to Results of Previous Sediment Contamination Studies	5-4
	Comparison of NSI Evaluation Results to Fish Consumption Advisories	5-5
	Sensitivity of Selected PCB Evaluation Parameters	5-7
	Strengths of the NSI Data Evaluation	5-8
	Limitations of the NSI Data Evaluation	5-10
	Limitations of Data	5-10
	Limitations of Approach	5-12
6	Recommendations	6-1
	Recommendation 1: Further Investigate Conditions in the 96 Targeted Watersheds ..	6-1
	Recommendation 2: Coordinate Efforts to Address Sediment Quality Through Watershed Management Programs	6-2
	Recommendation 3: Incorporate a Weight-of-Evidence Approach and Measures of Chemical Bioavailability into Sediment Monitoring Programs	6-2
	Recommendation 4: Evaluate the NSI's Coverage and Capabilities and Provide Better Access to Information in the NSI	6-3
	Recommendation 5: Develop Better Monitoring and Assessment Tools	6-4
	Glossary	Glossary-1
	Acronyms	Acronyms-1
	References	References-1
	Appendices	
	A. Detailed Description of NSI Data	A-1
	B. Description of Evaluation Parameters Used in the NSI Data Evaluation	B-1
	C. Method for Selecting Biota-Sediment Accumulation Factors and Percent Lipids in Fish Tissue Used for Deriving Theoretical Bioaccumulation Potentials	C-1
	D. Screening Values for Chemicals Evaluated	D-1
	E. Cancer Slope Factors and Noncancer Reference Doses Used to Develop EPA Risk Levels	E-1
	F. Species Characteristics Related to NSI Bioaccumulation Data	F-1
	G. Notes on the Methodology for Evaluating Sediment Toxicity Tests	G-1
	H. Additional Analyses for PCBs and Mercury	H-1
	I. NSI Data Evaluation Approach Recommended at the National Sediment Inventory Workshop, April 26-27, 1994	I-1

Tables

<i>Table</i>	<i>Page</i>
2-1	Number of Stations Evaluated in the NSI by State 2-5
2-2	NSI Data Evaluation Approach 2-9
3-1	National Assessment: Evaluation of Results for Sampling Stations and River Reaches by EPA Region 3-3
3-2	Chemicals or Chemical Groups Most Often Associated With Tier 1 or Tier 2 Sampling Station Classifications 3-7
3-3	Number of Sampling Stations Classified as Tier 1 and Tier 2 Based on Each Component of the Evaluation Approach 3-11
3-4	USGS Cataloging Unit Numbers and Names for Watersheds Containing APCs 3-14
3-5	River Reaches With 10 or More Tier 1 Sampling Stations Located in Watershed Containing APCs 3-17
3-6	Increased Number of Sampling Stations Classified as Tier 1 and Tier 2 by Including Wildlife Criteria in the National Assessment 3-20
3-7	Region 1: Evaluation Results for Sampling Stations and River Reaches by State 3-23
3-8	Region 1: Watersheds Containing Areas of Probable Concern for Sediment Contamination 3-25
3-9	Region 1: Water Bodies With Sampling Stations Classified as Tier 1 Located in Watersheds Containing APCs 3-25
3-10	Region 1: Chemicals Most Often Associated With Tier 1 or Tier 2 Sampling Station Classifications 3-26
3-11	Region 2: Evaluation Results for Sampling Stations and River Reaches by State 3-28
3-12	Region 2: Watersheds Containing Areas of Probable Concern for Sediment Contamination 3-30
3-13	Region 2: Water Bodies With Sampling Stations Classified as Tier 1 Located in Watersheds Containing APCs 3-30
3-14	Region 2: Chemicals Most Often Associated With Tier 1 or Tier 2 Sampling Station Classifications 3-31
3-15	Region 3: Evaluation Results for Sampling Stations and River Reaches by State 3-33
3-16	Region 3: Watersheds Containing Areas of Probable Concern for Sediment Contamination 3-35
3-17	Region 3: Water Bodies With Sampling Stations Classified as Tier 1 Located in Watersheds Containing APCs 3-35

Tables (continued)

3-18	Region 3: Chemicals Most Often Associated With Tier 1 or Tier 2 Sampling Station Classifications	3-36
3-19	Region 4: Evaluation Results for Sampling Stations and River Reaches by State	3-38
3-20	Region 4: Watersheds Containing Areas of Probable Concern for Sediment Contamination	3-40
3-21	Region 4: Water Bodies With Sampling Stations Classified as Tier 1 Located in Watersheds Containing APCs	3-41
3-22	Region 4: Chemicals Most Often Associated With Tier 1 or Tier 2 Sampling Station Classifications	3-42
3-23	Region 5: Evaluation Results for Sampling Stations and River Reaches by State	3-44
3-24	Region 5: Watersheds Containing Areas of Probable Concern for Sediment Contamination	3-46
3-25	Region 5: Water Bodies With Sampling Stations Classified as Tier 1 Located in Watersheds Containing APCs	3-47
3-26	Region 5: Chemicals Most Often Associated With Tier 1 or Tier 2 Sampling Station Classifications	3-48
3-27	Region 6: Evaluation Results for Sampling Stations and River Reaches by State	3-50
3-28	Region 6: Watersheds Containing Areas of Probable Concern for Sediment Contamination	3-52
3-29	Region 6: Water Bodies With Sampling Stations Classified as Tier 1 Located in Watersheds Containing APCs	3-52
3-30	Region 6: Chemicals Most Often Associated With Tier 1 or Tier 2 Sampling Station Classifications	3-53
3-31	Region 7: Evaluation Results for Sampling Stations and River Reaches by State	3-55
3-32	Region 7: Watersheds Containing Areas of Probable Concern for Sediment Contamination	3-57
3-33	Region 7: Water Bodies With Sampling Stations Classified as Tier 1 Located in Watersheds Containing APCs	3-57
3-34	Region 7: Chemicals Most Often Associated With Tier 1 or Tier 2 Sampling Station Classifications	3-58
3-35	Region 8: Evaluation Results for Sampling Stations and River Reaches by State	3-60
3-36	Region 8: Chemicals Most Often Associated With Tier 1 or Tier 2 Sampling Station Classifications	3-62

Tables (continued)

3-37	Region 9: Evaluation Results for Sampling Stations and River Reaches by State	3-64
3-38	Region 9: Watersheds Containing Areas of Probable Concern for Sediment Contamination	3-66
3-39	Region 9: Water Bodies With Sampling Stations Classified as Tier 1 Located in Watersheds Containing APCs	3-66
3-40	Region 9: Chemicals Most Often Associated With Tier 1 or Tier 2 Sampling Station Classifications	3-67
3-41	Region 10: Evaluation Results for Sampling Stations and River Reaches by State	3-69
3-42	Region 10: Watersheds Containing Areas of Probable Concern for Sediment Contamination	3-71
3-43	Region 10: Water Bodies With Sampling Stations Classified as Tier 1 Located in Watersheds Containing APCs	3-71
3-44	Region 10: Chemicals Most Often Associated With Tier 1 or Tier 2 Sampling Station Classifications	3-72
3-45	Potentially Highly Contaminated Sites Not Identified in the NSI Evaluation	3-73
4-1	Correlations of Sources to Chemical Classes of Sediment Contaminants	4-4
4-2	Tier 1 and Tier 2 Station Classification by Chemical Class and Land Uses in Watersheds Containing APCs	4-9
4-3	Comparison of Percent Agricultural Land Use in Watersheds Containing APCs to Percent of Tier 1 and Tier 2 Stations by Chemical Class	4-13
4-4	Comparison of Percent Urban Land Use in Watersheds Containing APCs to Percent of Tier 1 and Tier 2 Stations by Chemical Class	4-14
5-1	Comparison of Contaminants Most Often Associated With Fish Consumption Advisories and Those Which Most Often Cause Stations To Be Placed in Tier 1 or Tier 2 Based on the NSI Data Evaluation	5-5
5-2	National Sediment Inventory Database: Summary of QA/QC Information	5-11

Figures

<u>Figure</u>	<u>Page</u>
2-1 NSI Sediment Sampling Stations Evaluated	2-6
2-2 NSI Tissue Residue Sampling Stations Evaluated	2-7
2-3 NSI Toxicity Test Stations Evaluated	2-8
2-4 Aquatic Life Assessments: Sediment Chemistry Analysis for Organic Chemicals and Metals Not Included in the AVS Analysis	2-9
2-5 Aquatic Life Assessments: Sediment Chemistry Analysis for Divalent Metals	2-10
2-6 Aquatic Life Assessments: Sediment Toxicity Analysis	2-10
2-7 Human Health Assessments: Sediment Chemistry and Fish Tissue Residue Analysis (excluding dioxins and PCBs)	2-11
2-8 Human Health Assessments: PCBs and Dioxin in Fish Tissue Analysis	2-11
3-1 Location of All NSI Sampling Stations	3-2
3-2 Sampling Stations Classified as Tier 1 (Associated Adverse Effects Probable)	3-4
3-3 National Assessment: Percent of River Reaches That Include Tier 1, Tier 2, and Tier 3 Sampling Stations	3-5
3-4 National Assessment: Percent of NSI Measurements That Indicate Potential Risk	3-6
3-5 Sampling Stations Classified as Tier 1 or Tier 2 for Potential Risk to Aquatic Life ..	3-9
3-6 Sampling Stations Classified as Tier 1 or Tier 2 for Potential Risk to Human Health	3-10
3-7 Watersheds Identified as Containing APCs	3-13
3-8 National Assessment: Watershed Classifications	3-16
3-9 Sampling Stations Classified as Tier 1 or Tier 2 Based on Wildlife Criteria	3-19
3-10 Region 1: Percent of River Reaches That Include Tier 1, Tier 2, and Tier 3 Sampling Stations	3-22
3-11 Region 1: Watershed Classifications	3-22
3-12 Region 1: Location of Sampling Stations Classified as Tier 1 or Tier 2 and Watersheds Containing Areas of Probable Concern for Sediment Contamination	3-24
3-13 Region 2: Percent of River Reaches That Include Tier 1, Tier 2, and Tier 3 Sampling Stations	3-27
3-14 Region 2: Watershed Classifications	3-27
3-15 Region 2: Location of Sampling Stations Classified as Tier 1 or Tier 2 and Watersheds Containing Areas of Probable Concern for Sediment Contamination ...	3-29
3-16 Region 2: Percent of River Reaches That Include Tier 1, and Tier 3 Sampling Stations	3-32

Figures (continued)

3-17	Region 3: Watershed Classifications	3-32
3-18	Region 3: Location of Sampling Stations Classified as Tier 1 or Tier 2 and Watersheds Containing Areas of Probable Concern for Sediment Contamination	3-34
3-19	Region 4: Percent of River Reaches That Include Tier 1, Tier 2, and Tier 3 Sampling Stations	3-37
3-20	Region 4: Watershed Classifications	3-37
3-21	Region 4: Location of Sampling Stations Classified as Tier 1 or Tier 2 and Watersheds Containing Areas of Probable Concern for Sediment Contamination	3-39
3-22	Region 5: Percent of River Reaches That Include Tier 1, Tier 2, and Tier 3 Sampling Stations	3-43
3-23	Region 5: Watershed Classifications	3-43
3-24	Region 5: Location of Sampling Stations Classified as Tier 1 or Tier 2 and Watersheds Containing Areas of Probable Concern for Sediment Contamination	3-45
3-25	Region 6: Percent of River Reaches That Include Tier 1, Tier 2, and Tier 3 Sampling Stations	3-49
3-26	Region 6: Watershed Classifications	3-49
3-27	Region 6: Location of Sampling Stations Classified as Tier 1 or Tier 2 and Watersheds Containing Areas of Probable Concern for Sediment Contamination	3-51
3-28	Region 7: Percent of River Reaches That Include Tier 1, Tier 2, and Tier 3 Sampling Stations	3-54
3-29	Region 7: Watershed Classifications	3-54
3-30	Region 7: Location of Sampling Stations Classified as Tier 1 or Tier 2 and Watersheds Containing Areas of Probable Concern for Sediment Contamination	3-56
3-31	Region 8: Percent of River Reaches That Include Tier 1, Tier 2, and Tier 3 Sampling Stations	3-59
3-32	Region 8: Watershed Classifications	3-59
3-33	Region 8: Location of Sampling Stations Classified as Tier 1 or Tier 2	3-61
3-34	Region 9: Percent of River Reaches That Include Tier 1, Tier 2, and Tier 3 Sampling Stations	3-63
3-35	Region 9: Watershed Classifications	3-63
3-36	Region 9: Location of Sampling Stations Classified as Tier 1 or Tier 2 and Watersheds Containing Areas of Probable Concern for Sediment Contamination	3-65
3-37	Region 10: Percent of River Reaches That Include Tier 1, Tier 2, and Tier 3 Sampling Stations	3-68

Figures (continued)

3-38	Region 10: Watershed Classifications	3-68
3-39	Region 10: Location of Sampling Stations Classified as Tier 1 or Tier 2 and Watersheds Containing Areas of Probable Concern for Sediment Contamination	3-70
3-40	Location of Potentially Highly Contaminated Water Bodies Not Identified in the NSI Evaluation	3-74
4-1	Average Percent Contamination in Watersheds Containing APCs by Chemical Class	4-3
4-2	Percent Tier 1 and Tier 2 Stations vs. Agricultural Land Use in APCs	4-13
4-3	Percent Tier 1 and Tier 2 Stations vs. Total Urban Land Use in APCs	4-14
5-1	Tier 1 and Tier 2 Sampling Stations for Potential Risk to Human Health Located Within Water Bodies With Fish Consumption Advisories in Place for the Same Chemical Responsible for the Tier 1 or Tier 2 Classification	5-6
5-2	Sampling Stations Classified as Tier 1 or Tier 2 for Potential Risk to Human Health Excluding PCBs	5-9

Acknowledgments

The United States Environmental Protection Agency's Office of Science and Technology (OST) produced this report with technical support from Tetra Tech, Inc., under EPA Contract Number 68-C3-0374. Staff from EPA Regional Offices and other headquarters program offices have participated in this project, provided technical guidance, and reviewed previous reports. We greatly appreciate their efforts and helpful comments. In particular, we wish to acknowledge Catherine Fox who served as the initial project officer and oversaw the development of the database and evaluation methodology. We also wish to express our appreciation to the EPA Regional Office and State personnel who participated in the review of the preliminary evaluation of sediment chemistry data, as well as to the persons who participated in national workshops in April 1993 (data compilation) and April 1994 (evaluation methodology).

We wish to offer a special expression of gratitude to several Agency scientists who provided technical information, guidance, and expert counsel to OST. Gerald Ankley, Phil Cook, David Hansen, Richard Swartz, and Nelson Thomas provided technical assistance in refining the evaluation methodology. Charles Stephan assisted in the process of reviewing aquatic toxicity literature. Samuel Karickhoff and J. MacArthur Long reviewed chemical property literature and recommended organic carbon partitioning coefficients for specific chemicals.

We also wish to acknowledge the following persons who provided external peer review of the evaluation methodology and its application to the data compiled for this report: William Adams of Kennecott Utah Copper Corporation in Magna, Utah; Derek Muir of the Freshwater Institute in Winnipeg, Manitoba; Spyros Pavlou of URS Grenier in Seattle, Washington; Anne Spacie of Purdue University in Lafayette, Indiana; and William Stubblefield of ENSR Technology in Fort Collins, Colorado. These persons reviewed the soundness of proposed evaluation methods for intended purposes, and recommended appropriate and meaningful presentation and interpretation of results. Chapter 4 and the Executive Summary of this document were not included in prior reviews because they had not yet been completed. Participation in the review process does not imply concurrence by these individuals with all observations and recommendations contained in this report.

We greatly appreciate the comments received from various stakeholders during the review of the July 1996 of this report. Our thanks to all state government officials, trade association representatives, environmental advocacy professionals, and members of the scientific community who provided valuable insights. We also wish to acknowledge the consultation with the National Oceanic and Atmospheric Administration, the United States Army Corps of Engineers, and the United States Geological Survey.

Finally, we wish to recognize Andrew Zacherle, Jon Harcum, Alex Trounov, Esther Peters, and all other participating staff and management at Tetra Tech, Inc. for their efforts and professionalism in providing technical support and data management.

James Keating, Principal Investigator
Thomas Armitage, Acting Chief, Risk Assessment and Management Branch
Elizabeth Southerland, Acting Director, Standards and Applied Science Division

Executive Summary

This report, *The Incidence and Severity of Sediment Contamination in Surface Waters of the United States*, describes the accumulation of chemical contaminants in river, lake, ocean, and estuary bottoms and includes a screening assessment of the potential for associated adverse effects on human and environmental health. The United States Environmental Protection Agency (EPA) prepared this report to Congress in response to requirements set forth in the Water Resources Development Act (WRDA) of 1992, which directed EPA, in consultation with the National Oceanic and Atmospheric Administration (NOAA) and the U.S. Army Corps of Engineers (USACE), to conduct a comprehensive national survey of data regarding the quality of aquatic sediments in the United States. The Act required EPA to compile all existing information on the quantity, chemical and physical composition, and geographic location of pollutants in aquatic sediment, including the probable source of such pollutants and identification of those sediments which are contaminated. The Act further required EPA to report to the Congress the findings, conclusions, and recommendations of such survey, including recommendations for actions necessary to prevent contamination of aquatic sediments and to control sources of contamination. The Act also requires EPA to establish a comprehensive and continuing program to assess aquatic sediment quality. As part of this continuing program, EPA must submit a national sediment quality report to Congress every 2 years.

To comply with the WRDA mandate, EPA's Office of Science and Technology (OST) initiated the National Sediment Inventory (NSI). The NSI is a compilation of existing sediment quality data; protocols used to evaluate the data; and various reports and analyses produced to present the findings, conclusions, and recommendations for action. EPA produced this first report to Congress in four volumes:

- **Volume 1: National Sediment Quality Survey**—Screening analysis to qualitatively assess the probability of associated adverse human or ecological effects based on a weight-of-evidence evaluation
- **Volume 2: Data Summaries for Areas of Probable Concern (APCs)**—Sampling station location maps and chemical and biological summary data for watersheds containing APCs
- **Volume 3: National Sediment Contaminant Point Source Inventory**—Screening analysis to identify probable point source contributors of sediment pollutants
- **Volume 4: National Sediment Contaminant Nonpoint Source Inventory**—Screening analysis to identify probable nonpoint source contributors of sediment pollutants (in preparation for subsequent biennial reports)

EPA prepared Volume I, the *National Sediment Quality Survey*, to provide a national baseline screening-level assessment of contaminated sediment over a time period of the past 15 years. To accomplish this objective, EPA applied assessment protocols to existing available data in a uniform fashion. EPA intended to accurately depict and characterize the incidence and severity of sediment contamination based on the *probability* of adverse effects to human health and the environment. The process has demonstrated the use of "weight-of-evidence" measures (including measures of the bioavailability of toxic chemicals) in sediment quality assessment. Information contained in this volume may be used to further investigate sediment contamination on a national, regional, and site-specific scale. Further studies may involve toxicological investigations, risk assessment, analyses of temporal and spatial trends, feasibility of natural recovery, and source control.

The *National Sediment Quality Survey* is the first comprehensive EPA analysis of sediment chemistry and related biological data to assess what is known about the national incidence and severity of sediment contamination. This volume presents a screening-level identification of sampling stations in several areas across the country where sediment is contaminated at levels suggesting an increased probability of adverse effects on aquatic life and human health. Based on the number and percentage of sampling stations containing contaminated

sediment within watershed boundaries, EPA identified a number of watersheds containing areas of probable concern where additional studies may be needed to draw conclusions regarding adverse effects and the need for actions to reduce risks.

In addition to this and future reports to Congress, EPA anticipates that products generated through the NSI will provide managers at the federal, state, and local levels with information. Many of the NSI data were obtained by local watershed managers from monitoring programs targeted toward areas of known or suspected contamination. NSI data and evaluation results can assist local watershed managers by providing additional data that they may not have, demonstrating the application of a weight-of-evidence approach for identifying and screening contaminated sediment locations, and allowing researchers to draw upon a large data set of information to conduct new analyses that ultimately will be relevant for local assessments.

Description of the NSI Database

The NSI is the largest set of sediment chemistry and related biological data ever compiled by EPA. It includes approximately two million records for more than 21,000 monitoring stations across the country. To efficiently collect usable information for inclusion in the NSI, EPA sought data that were available in electronic format, represented broad geographic coverage, and represented specific sampling locations identified by latitude and longitude coordinates. The minimum data requirements for inclusion of computerized data in the NSI were monitoring program, sampling date, latitude and longitude coordinates, and measured units. Additional data fields such as sampling method and other quality assurance/quality control information were retained in the NSI if available, but were not required for a data set to be included in the NSI.

The NSI includes data from the following data storage systems and monitoring programs:

- Selected data from EPA's Storage and Retrieval System (STORET)
- NOAA's Coastal Sediment Inventory (COSED)
- EPA's Ocean Data Evaluation System (ODES)
- EPA Region 4's Sediment Quality Inventory
- Gulf of Mexico Program's Contaminated Sediment Inventory

- EPA Region 10/USACE Seattle District's Sediment Inventory
- EPA Region 9's Dredged Material Tracking System (DMATS)
- EPA's Great Lakes Sediment Inventory
- EPA's Environmental Monitoring and Assessment Program (EMAP)
- United States Geological Survey (Massachusetts Bay) Data

In addition to sediment chemistry data, the NSI includes tissue residue, toxicity, benthic abundance, histopathology, and fish abundance data. The sediment chemistry, tissue residue, and toxicity data were evaluated for this report to Congress. Data from 1980 to 1993 were used in the NSI data evaluation, but older data also are maintained in the NSI.

Evaluation Approach

The WRDA defines contaminated sediment as aquatic sediment that contains chemical substances in excess of appropriate geochemical, toxicological, or sediment quality criteria or measures; or is otherwise considered to pose a threat to human health or the environment. The approach used to evaluate the NSI data focuses on the risk to benthic organisms exposed directly to contaminated sediments, and the risk to human consumers of organisms exposed to sediment contaminants. EPA evaluated sediment chemistry data, chemical residue levels in edible tissue of aquatic organisms, and sediment toxicity data taken at the same sampling station (where available) using a variety of assessment methods.

The following measurement parameters and techniques were used alone or in combination to evaluate the probability of adverse effects:

Aquatic Life

- (1) Comparison of sediment chemistry measurements to sediment chemistry screening values
 - Draft sediment quality criteria (SQC's)
 - Sediment quality advisory levels (SQAL's)
 - Effects range-median (ERM) and effects range-low (ERL) values

- Probable effects levels (PELs) and threshold effects levels (TELs)
 - Apparent effects thresholds (AETs)
- (2) Comparison of the molar concentration of acid volatile sulfides ([AVS]) in sediment to the molar concentration of simultaneously extracted metals ([SEM]) in sediment (under equilibrium conditions, sediment with [EVS] greater than [SEM] will not demonstrate toxicity from metals)
- (3) Lethality based on sediment toxicity data

Human Health

- (4) Comparison of theoretical bioaccumulation potential (TBP) of measured sediment contaminants to:
- EPA cancer and noncancer risk levels
 - Food and Drug Administration (FDA) tolerance, action, or guidance values
- (5) Comparison of fish tissue contaminant levels to
- EPA cancer and noncancer risk levels
 - FDA tolerance, action, or guidance values

The sediment chemistry screening values used in this report are not regulatory criteria, site-specific cleanup standards, or remediation goals. Sediment chemistry screening values are reference values above which a sediment ecotoxicological assessment might indicate a potential threat to aquatic life. For example, independent analyses of matching chemistry and bioassay data reveal that ERL/ERMs and TEL/PELs frequently classify samples correctly either as nontoxic when chemical concentrations are lower than all these values or as toxic when concentrations exceed these values. (See Appendix B.) The sediment chemistry screening values include both theoretically and empirically derived values. The theoretically derived screening values (e.g., SQC, SQAL, [SEM]-[AVS]) rely on the physical/chemical properties of sediment and chemicals to predict the level of contamination that would not cause an adverse effect on aquatic life under equilibrium conditions in sediment. The empirically derived, or correlative, screening values (e.g., ERM/ERL, PEL/TEL, AET) rely on paired field and laboratory data to relate incidence of observed biological effects to the dry-weight sediment concentration of a specific chemical. Correlative screening values can relate measured concentration to a probability of association with adverse effects, but do not

establish cause and effect for a specific chemical. Toxicity data were used to classify sediment sampling stations based on their demonstrated lethality to aquatic life in laboratory bioassays.

Under an assumed exposure scenario, theoretical bioaccumulation potential (TBP) and tissue residue data can indicate potential adverse effects on humans from the consumption of fish that become contaminated through exposure to contaminated sediment. TBP is an estimate of the equilibrium concentration (concentration that does not change with time) of a contaminant in tissues of aquatic organisms if the sediment in question were the only source of contamination to the organism. At present, the TBP calculation can be performed only for nonpolar organic chemicals. The TBP is estimated from the concentration of contaminant in the sediment, the organic carbon content of the sediment, the lipid content of the organism, and the relative affinity of the chemical for sediment organic carbon and animal lipid content. This relative affinity is measured in the field and is called a biota-sediment accumulation factor (BSAF, as discussed in detail in Appendix C). In practice, field measured BSAFs can vary by an order of magnitude or greater for individual compounds depending on location and time of measurement. For this evaluation, EPA selected BSAFs that represents the central tendency, suggesting an approximate 50 percent chance that an associated tissue residue level would exceed a screening risk value.

Uncertainty is associated with site-specific measures, assessment techniques, exposure scenarios, and default parameter selections. Many mitigating biological, chemical, hydrological, and habitat factors may affect whether sediment poses a threat to aquatic life or human health. Because of the limitations of the available sediment quality measures and assessment methods, EPA characterizes this evaluation as a screening-level analysis. Similar to a potential human illness screen, a screening-level analysis should pick up potential problems and note them for further study. A screening-level analysis will typically identify many potential problems that prove not to be significant upon further analysis. Thus, classification of sampling stations in this analysis is not meant to be definitive, but is intended to be inclusive of potential problems arising from persistent metal and organic chemical contaminants. For this reason, EPA elected to evaluate data collected from 1980 to 1993 and to evaluate each chemical or biological measurement taken at a given sampling station individually. A single measurement of a chemical at a sampling station, taken at any point in time over the past 15 years, may have been sufficient to categorize the sampling station as having an increased probability of association with adverse effects on aquatic life or human health.

In this report, EPA associates sampling stations with their "probability of adverse effects." Each sampling station falls into one of three categories, or tiers:

- Tier 1: associated adverse effects are probable
- Tier 2: associated adverse effects are possible, but expected infrequently
- Tier 3: no indication of associated adverse effects (any sampling station not classified as Tier 1 or Tier 2; includes sampling stations for which substantial data were available, as well as sampling stations for which limited data were available).

The potential risk of adverse effects on aquatic life and human health is greatest in areas with a multitude of contaminated locations. The assessment of individual sampling stations is useful for estimating the number and distribution of contaminated spots and overall magnitude of sediment contamination in monitored waterbodies of the United States. However, a single "hot spot" might not pose a great threat to either the benthic community at large or consumers of resident fish because the spatial extent of exposure could be small. On the other hand, if many contaminated spots are located in close proximity, the spatial extent and probability of exposure are much greater. EPA examined sampling station classifications within watersheds to identify areas of probable concern for sediment contamination (APCs), where the exposure of benthic organisms and resident fish to contaminated sediment might be more frequent. In this report, EPA defines watersheds by 8-digit United States Geological Survey (USGS) hydrologic unit codes, which are roughly the size of a county. Watersheds containing APCs are those in which 10 or more sampling stations were classified as Tier 1, and in which at least 75 percent of all sampling stations were categorized as either Tier 1 or Tier 2.

The definition of "area of probable concern" was developed for this report to identify watersheds for which further study of the effects and sources of sediment contamination, and possible risk reduction needs, would be warranted. Where data have been generated through intensive sampling in areas of known or suspected contamination within a watershed, the APC definition should identify watersheds which contain even relatively small areas that are considerably contaminated. However, this designation does not imply that sediment throughout the entire watershed, which is typically very large compared to the extent of available sampling data, is contaminated. On the other hand, where data have been generated through comprehensive sampling, or where sampling stations were selected randomly

or evenly distributed throughout a sampling grid, the APC definition might not identify watersheds that contain small or sporadically contaminated areas. A comprehensively surveyed watershed of the size typically delineated by a USGS cataloging unit might contain small but significant areas that are considerably contaminated, but might be too large in total area for 75 percent of all sampling stations to be classified as Tier 1 or Tier 2. Limited random or evenly distributed sampling within such a watershed also might not yield 10 Tier 1 sampling stations. Thus, the process used to identify watersheds containing APCs may both include some watersheds with limited areas of contamination and omit some watersheds with significant contamination. However, given available data EPA believes it represents a reasonable screening analysis to identify watersheds where further study is warranted.

Strengths and Limitations

For this report to Congress, EPA has compiled the most extensive database of sediment quality information currently available in electronic format. To evaluate these data, EPA has applied sediment assessment techniques in a weight-of-evidence approach recommended by national experts. The process to produce this report to Congress has engaged a broad array of government, industry, academic, and professional experts and stakeholders in development and review stages. The evaluation approach uses sediment chemistry, tissue residue, and toxicity test results. The assessment tools employed in this analysis have been applied in North America, with results published in peer-reviewed literature. Toxicity test data were generated using established standard methods employed by multiple federal agencies. The evaluation approach addresses potential impacts on both aquatic life and human health. Some chemicals pose a greater risk to human health than to aquatic life; for others, the reverse is true. By evaluating both potential human health and aquatic life impacts, EPA has ensured that the most sensitive endpoint is used to assess environmental impacts.

Two general types of limitations are associated with this report to Congress—limitations of the compiled data and limitations of the evaluation approach. Limitations of the compiled data include the mixture of data sets derived from different sampling strategies, incomplete sampling coverage, the age and quality of data, and the lack of measurements of important assessment parameters. Limitations of the evaluation approach include uncertainties in the interpretive tools to assess sediment quality, lack of quantitative risk assessment that considers exposure potentials as well as contamination (e.g., fish consumption rates within APCs for human health risk), and the subsequent difficulties in interpreting assessment results.

These limitations and uncertainties are discussed in detail in Chapter 5 of this volume under "Limitations of the NSI Data Evaluation."

Data compiled for this report were generated using a number of different sampling strategies. Component sources contain data derived from different spatial sampling plans, sampling methods, and analytical methods. Most of the NSI data were compiled from nonrandom monitoring programs. Such monitoring programs focus their sampling efforts on areas where contamination is known or suspected to occur. Reliance on these data is consistent with the stated objective of this survey: to identify those sediments which are contaminated. However, one cannot accurately make inferences regarding the overall condition of the Nation's sediment, or characterize the "percent contamination," using the data in the NSI because uncontaminated areas are most likely substantially underrepresented.

Because this analysis is based only on readily available electronically formatted data, contamination problems exist at some locations where data are lacking. Conversely, older data might not accurately represent current sediment contamination conditions. The reliance on readily available electronic data has undoubtedly excluded a vast amount of information available from sources such as local and state governments and published academic studies. In addition, some data in the NSI were not evaluated because of questions concerning data quality or because no locational information (latitude and longitude) was available. NSI data do not evenly represent all geographic regions in the United States, nor do the data represent a consistent set of monitored chemicals.

EPA recognizes that sediment is dynamic and that great temporal and spatial variability in sediment quality exists. Movement of sediment is highly temporal, and dependent upon the physical and biological processes at work in the watershed. Some deposits will redistribute while others will remain static unless disturbed by extreme events. Because the data analyzed in this report were collected over a relatively long period of time, conditions might have improved or worsened since the sediment was sampled. Consequently, this report does not definitively assess the current condition of sediments, but serves as a baseline for future assessments

The lack of data required to apply some important assessment parameters hampered EPA's efforts to determine the incidence and severity of sediment contamination. For example, the component databases contain a dearth of total organic carbon (TOC) and acid volatile sulfide (AVS) measurements relative to the abundance of contaminant concentration measurements in bulk sedi-

ment. TOC and AVS are essential pieces of information for interpreting the bioavailability, and subsequent toxicity, of nonpolar organic and metal contaminants, respectively. In addition, matched sediment chemistry with toxicity tests, and matched sediment chemistry with tissue residue data, were typically lacking.

It is important to understand both the strengths and limitations of this analysis to appropriately interpret and use the information contained in this report. The limitations do not prevent intended uses, and future reports to Congress on sediment quality will contain less uncertainty. To ensure that future reports to Congress accurately reflect current knowledge concerning the conditions of the Nation's sediment as our knowledge and application of science evolve, the NSI will develop into a periodically updated, centralized assemblage of sediment quality measurements and state-of-the-art assessment techniques.

Findings

EPA evaluated more than 21,000 sampling stations nationwide as part of the NSI data evaluation. Of the sampling stations evaluated, 5,521 stations (26 percent) were classified as Tier 1, 10,401 (49 percent) were classified as Tier 2, and 5,174 (25 percent) were classified as Tier 3. This distribution suggests that state monitoring programs (accounting for the majority of NSI data) have been efficient and successful in focusing their sampling efforts on areas where contamination is known or suspected to occur. The frequency of Tier 1 classification based on all NSI data is greater than the frequency of Tier 1 classification based on data sets derived from purely random sampling.

The percentage of all NSI sampling stations where associated effects are "probable" or "possible but expected infrequently" (i.e., 26 percent in Tier 1 and 49 percent in Tier 2) does not represent the overall condition of sediment across the country: the overall extent of contaminated sediment is much less, as is the percentage of sampling stations where contamination is expected to actually exert adverse effects. For example, a reasonable estimate of the national extent of contamination leading to adverse effects to aquatic life is between 6 and 12 percent of sediment underlying surface waters (see Chapter 5 for expanded discussion of "extent of contamination"). This is primarily because most of the NSI data were obtained from monitoring programs targeted toward areas of known or suspected contamination (i.e., sampling stations were not randomly selected).

The NSI sampling stations were located in 6,744 individual river reaches (or water body segments) across the

contiguous United States, or approximately 11 percent of all river reaches in the country (based on EPA's River Reach File 1). A river reach can be part of a coastal shoreline, a lake, or a length of stream between two major tributaries ranging from approximately 1 to 10 miles long. As depicted in Figure 1, approximately 4 percent of all river reaches in the contiguous United States had at least one station categorized as Tier 1, approximately 5 percent of reaches had at least one station categorized as Tier 2 (but none as Tier 1), and all of the sampling stations were classified as Tier 3 in about 2 percent of reaches.

Watersheds containing areas of probable concern for sediment contamination (APCs) are those that include at least 10 Tier 1 sampling stations and in which at least 75 percent of all sampling stations were classified as either Tier 1 or Tier 2. The NSI data evaluation identified 96 watersheds throughout the United States as containing APCs (Figure 2 and Table 1). (The map numbers listed on Table 1 correspond to the numbered watersheds identified in Figure 2.) These watersheds represent about 5 percent of all watersheds in the United States (96 of 2,111). APC designation could result from extensive sampling throughout a watershed, or from intensive sampling at a single contaminated location or a few contaminated locations. In comparison to the overall results presented on Figure 1, sampling stations are located on an average of 46 percent of reaches within watersheds containing APCs. On the average, 30 percent of reaches in watersheds containing APCs have at least one Tier 1 sampling station, and 13 percent have no Tier 1 sampling station but at least one Tier 2 sampling station. In many of these watersheds, the risk might be concentrated on certain water bodies or river reaches. Within the 96 watersheds containing APCs, 57 river reaches include 10 or more Tier 1 sampling stations. For more detailed information concerning individual watersheds containing APCs, please consult Volume 2 of this report.

The evaluation results indicate that sediment contamination associated with probable or possible but infrequent adverse effects exists for both aquatic life and human health. More sampling stations were categorized as either Tier 1 or Tier 2 for aquatic life concerns than for human health concerns. About 41 percent more sampling stations were classified as Tier 1 for aquatic life (3,287 stations) than for human health (2,327 stations). About 60 percent more sampling stations

were categorized as Tier 2 for aquatic life (9,921 stations) than for human health (6,196 stations).

Recognizing the imprecise nature of some assessment parameters used in this report, Tier 1 sampling stations are distinguished from Tier 2 sampling stations based on the magnitude of a contaminant concentration in sediment, or the degree of corroboration among the different types of sediment quality measures. In response to uncertainty in both biological and chemical measures of sediment contamination, environmental managers must balance Type I errors (false positives: sediment classified as posing a threat that does not) with Type II errors (false negatives: sediment that poses a threat but was not classified as such). In screening analyses, the environmentally protective approach is to minimize Type II errors, which leave toxic sediment unidentified. To achieve a balance and to direct attention to areas most likely to be associated with adverse effects, Tier 1 sampling stations are intended to have a high rate of "correct" classification (e.g., sediment definitely posing or definitely not posing a threat) and a balance between Type I and Type II errors. On the other hand, to retain a sufficient degree of environmental conservatism in screening, Tier 2 sampling stations are intended to have a very low number of false negatives in exchange for a large number of false positives.

To help judge the effectiveness of the evaluation approach described previously, EPA examined the agreement between matched sediment chemistry and toxicity test re-

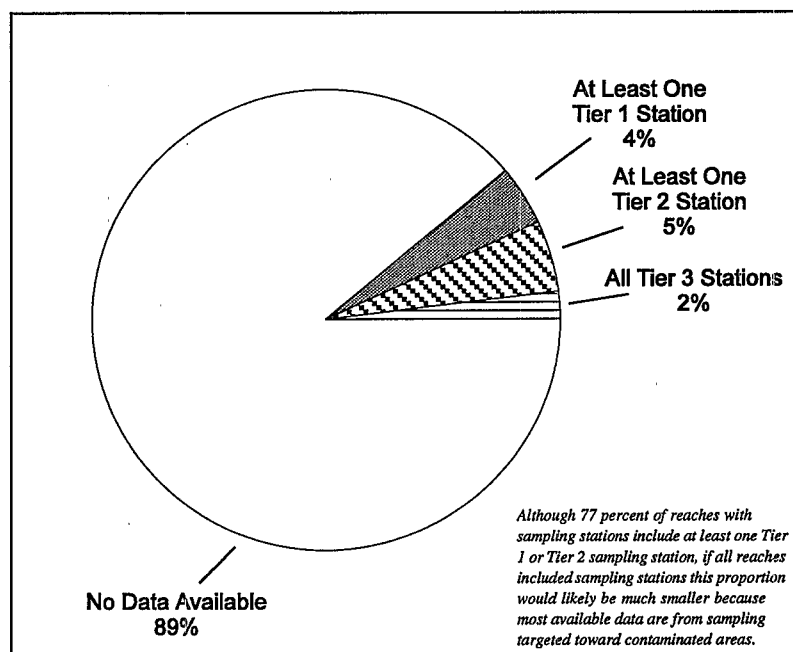

Figure 1. National Assessment: Percent of River Reaches That Include Tier 1, Tier 2, and Tier 3 Sampling Stations.

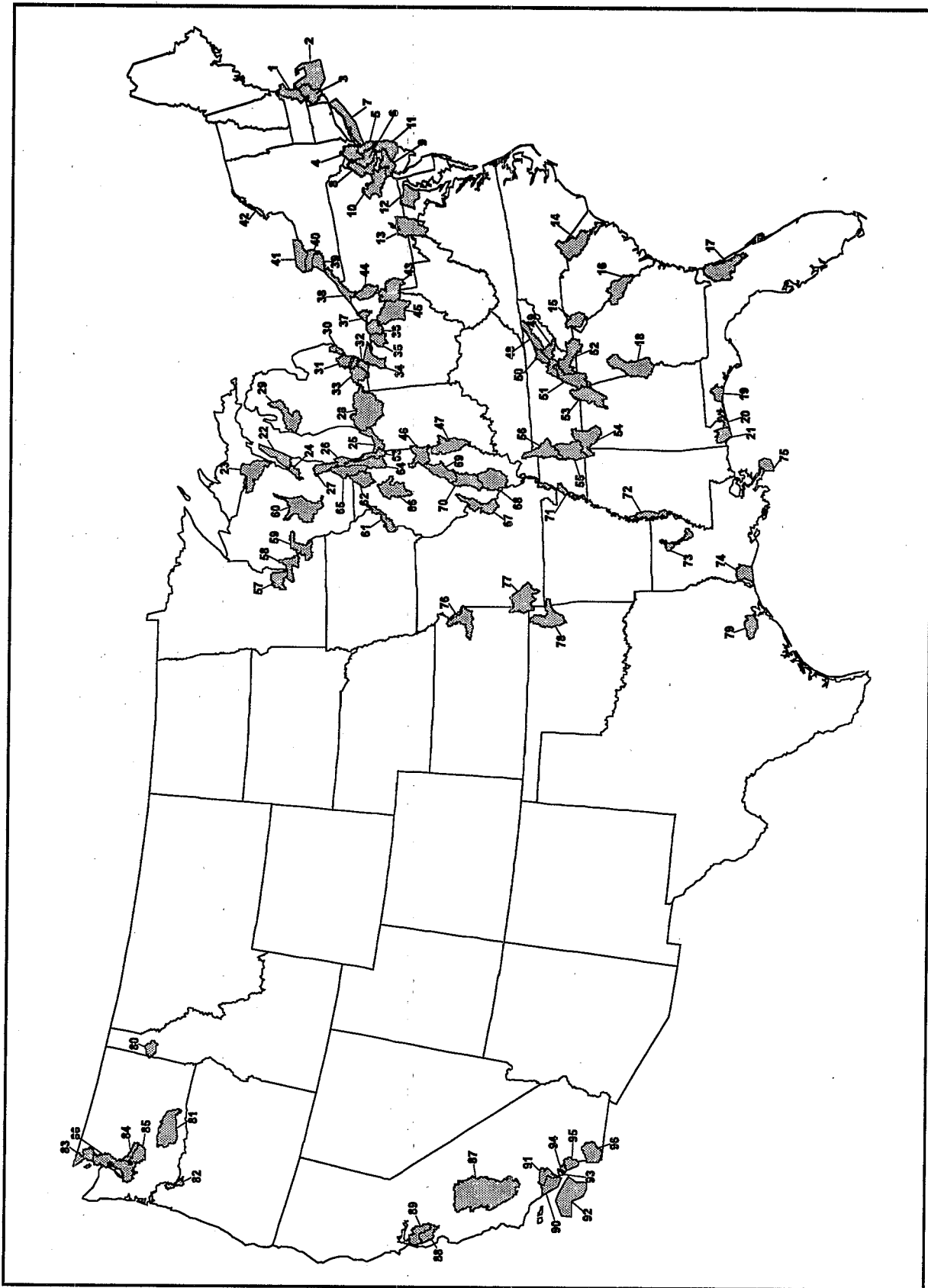

Figure 2. Watersheds Containing Areas of Probable Concern for Sediment Contamination (APCs).

Table 1. USGS Cataloging Unit Number and Name for Watersheds Containing APCs.

Map #	Cataloging Unit Number	Cataloging Unit Name
1	1090001	Charles
2	1090002	Cape Cod
3	1090004	Narragansett
4	2030103	Hackensack-Passaic
5	2030104	Sandy Hook-Staten Island
6	2030105	Raritan
7	2030202	Southern Long Island
8	2040105	Middle Delaware-Musconetcong
9	2040202	Lower Delaware
10	2040203	Schuylkill
11	2040301	Mullica-Toms
12	2060003	Gunpowder-Patapsco
13	2070004	Conococheague-Opequon
14	3040201	Lower Pee Dee
15	3060101	Seneca
16	3060106	Middle Savannah
17	3080103	Lower St. Johns
18	3130002	Middle Chattahoochee-Lake Harding
19	3140102	Choctawhatchee Bay
20	3140107	Perdido Bay
21	3160205	Mobile Bay
22	4030102	Door-Kewaunee
23	4030108	Menominee
24	4030204	Lower Fox
25	4040001	Little Calumet-Galien
26	4040002	Pike-Root
27	4040003	Milwaukee
28	4050001	St. Joseph
29	4060103	Manistee
30	4090002	Lake St. Clair
31	4090004	Detroit
32	4100001	Ottawa-Stony
33	4100002	Raisin
34	4100010	Cedar-Portage
35	4100012	Huron-Vermillion
36	4110001	Black-Rocky
37	4110003	Ashtabula-Chagrin

Table 1. (Continued)

Map #	Cataloging Unit Number	Cataloging Unit Name
38	4120101	Chautauqua-Conneaut
39	4120103	Buffalo-Eighteenmile
40	4120104	Niagara
41	4130001	Oak Orchard-Twelvemile
42	4150301	Upper St. Lawrence
43	5030101	Upper Ohio
44	5030102	Shenango
45	5040001	Tuscarawas
46	5120109	Vermilion
47	5120111	Middle Wabash-Busseron
48	6010104	Holston
49	6010201	Watts Bar Lake
50	6010207	Lower Clinch
51	6020001	Middle Tennessee-Chickamauga
52	6020002	Hiwassee
53	6030001	Guntersville Lake
54	6030005	Pickwick Lake
55	6040001	Lower Tennessee-Beech
56	6040005	Kentucky Lake
57	7010206	Twin Cities
58	7040001	Rush-Vermillion
59	7040003	Buffalo-Whitewater
60	7070003	Castle Rock
61	7080101	Copperas-Duck
62	7090006	Kishwaukee
63	7120003	Chicago
64	7120004	Des Plaines
65	7120006	Upper Fox
66	7130001	Lower Illinois-Senachwine Lake
67	71401001	Cahokia-Joachim
68	7140106	Big Muddy
69	7140201	Upper Kaskaskia
70	7140202	Middle Kaskaskia
71	8010100	Lower Mississippi-Memphis
72	8030209	Deer-Steele
73	8040207	Lower Ouachita

Table 1. (Continued)

Map #	Cataloging Unit Number	Cataloging Unit Name
74	8080206	Lower Calcasieu
75	8090100	Lower Mississippi-New Orleans
76	10270104	Lower Kansas
77	11070207	Spring
78	11070209	Lower Neosho
79	12040104	Buffalo-San Jacinto
80	17010303	Coeur D'Alene Lake
81	17030003	Lower Yakima
82	17090012	Lower Willamette
83	17110002	Strait of Georgia
84	17110013	Duwamish
85	17110014	Puyallup
86	17110019	Puget Sound
87	18030012	Tulare-Buena Vista Lakes
88	18050003	Coyote
89	18050004	San Francisco Bay
90	18070104	Santa Monica Bay
91	18070105	Los Angeles
92	18070107	San Pedro Channel Islands
93	18070201	Seal Beach
94	18070204	Newport Bay
95	18070301	Aliso-San Onofre
96	18070304	San Diego

sults for the 805 sampling stations where both data types are available. The toxicity test data indicate whether significant lethality to indicator organisms occurs as a result of exposure to sediment. Tier 1 classification for aquatic life effects from sediment chemistry data correctly matched toxicity test results for about three-quarters of the sampling stations, with the remainder balanced between false positives (12 percent) and false negatives (14 percent). In contrast, when Tier 2 classifications from sediment chemistry data are added in, false negatives drop to less than 1 percent at the expense of false positives (increases to 68 percent) and correctly matched sampling stations (drops to 30 percent). This result highlights the fact, already discussed above, that classification in Tier 2 is very conservative, and it does not indicate a high probability of adverse effects to aquatic life. If bioassay test results for chronic toxicity endpoints were included in the NSI evaluation, the rate of false

positives would likely decrease and correctly matched sampling stations would likely increase for both tiers.

Data related to more than 230 different chemicals or chemical groups were included in the NSI evaluation. Approximately 40 percent of these chemicals or chemical groups (97) were present at levels that resulted in classification of sampling stations as Tier 1 or Tier 2. The contaminants most frequently at levels in fish or sediment where associated adverse effects are probable include PCBs (58 percent of the 5,521 Tier 1 sampling stations) and mercury (20 percent of Tier 1 sampling stations). Pesticides, most notably DDT and metabolites at 15 percent of Tier 1 sampling stations, and polynuclear aromatic hydrocarbons (PAHs) such as pyrene at 8 percent of Tier 1 sampling stations, also were frequently at levels where associated adverse effects are probable.

Dry weight measures of divalent metals other than mercury (e.g., copper, cadmium, lead, nickel, and zinc) in sediment were not used to place a sampling station in Tier 1 without an associated measurement of acid volatile sulfide, a primary mediator of bioavailability for which data are not often available in the database. As a result, metals other than mercury (which also include arsenic, chromium, and silver) are solely responsible for only 6 percent of Tier 1 sampling stations and overlap with mercury or organic compounds at an additional 6 percent of Tier 1 sampling stations. In contrast, metals other than mercury are solely responsible for about 28 percent of the 15,922 Tier 1 and Tier 2 sampling stations and overlap with mercury or organic compounds at an additional 28 percent of Tier 1 and Tier 2 sampling stations. The remaining 44 percent of Tier 1 and Tier 2 sampling stations are classified solely for mercury or organic compounds.

Two important issues in interpreting the results of sampling station classification are naturally occurring "background" levels of chemicals and the effect of chemical mixtures. Site-specific naturally occurring (or background) levels of chemicals may be an important risk management consideration in examining sampling station classification. This is most often an issue for naturally occurring chemicals such as metals and PAHs. In addition, although the sediment chemistry screening levels for individual chemicals are used as indicators of potential adverse biological effects, other co-occurring chemicals (which may or may not be measured) can cause or contribute to observed adverse effects at specific locations.

Because PCBs were the contaminants most often responsible for Tier 1 classifications in the NSI evaluation, and because EPA took a precautionary approach (described in Chapter 2) in evaluating the effects of PCB exposure, the Agency conducted two separate analyses of PCB data to determine the impact of the precautionary approach on the overall classification of NSI sampling stations. EPA first examined the effect of excluding PCBs entirely from the NSI evaluation. If PCBs were excluded, the number of Tier 1 stations would be reduced by 42 percent, from 5,521 to 3,209 stations. The number of Tier 2 stations would be increased by 18 percent, from 10,401 to 11,957 stations. This increase reflects the movement of stations formerly classified as Tier 1 into Tier 2. In the second PCB evaluation, EPA evaluated the effect on the overall results of using a less precautionary noncancer screening value (rather than the cancer screening value) for predicting human health risk associated with PCB sediment contamination. When the noncancer screening value was used, the number of Tier 1 stations decreased by 12

percent, from 5,521 to 4,844 stations, and the number of Tier 2 stations increased by 4 percent, from 10,401 to 10,802 stations.

Conclusions and Recommendations

The characteristics of the NSI data, as well as the degree of certainty afforded by available assessment tools, allow neither an absolute determination of adverse effects on human health or the environment at any location, nor a determination of the areal extent of contamination on a national scale. However, the evaluation results strongly suggest that sediment contamination may be significant enough to pose potential risks to aquatic life and human health in some locations. The evaluation methodology was designed for the purpose of a screening-level assessment of sediment quality; further evaluation would be required to confirm that sediment contamination poses actual risks to aquatic life or human health for any given sampling station or watershed.

EPA's evaluation of the NSI data was the most geographically extensive investigation of sediment contamination ever performed in the United States. The evaluation was based on procedures to address the probability of adverse effects on aquatic life and human health. Based on the evaluation, sediment contamination exists at levels where associated adverse effects are probable (Tier 1) in some locations within each region and state of the country. The water bodies affected include streams, lakes, harbors, nearshore areas, and oceans. At the Tier 1 level, PCBs, mercury, organochlorine pesticides, and PAHs are the most frequent chemical indicators of sediment contamination.

The results of the NSI data evaluation must be interpreted in the context of data availability. Many states and EPA Regions appear to have a much greater incidence of sediment contamination than others. To some degree, this appearance reflects the relative abundance of readily available electronic data, not necessarily the relative incidence of sediment contamination.

Although the APCs were selected by means of a screening exercise, EPA believes that they represent the highest priority for further ecotoxicological assessments, risk analysis, temporal and spatial trend assessment, contaminant source evaluation, and management action because of the preponderance of evidence in these areas. Although the procedure for classifying APCs using multiple sampling stations was intended to minimize the probability of making an erroneous classification, further evaluation of conditions in watersheds containing APCs is necessary because the same mitigating factors that might

reduce the probability of associated adverse effects at one sampling station might also affect neighboring sampling stations.

EPA chose the watershed as the unit of spatial analysis because many state and federal water and sediment quality management programs, as well as data acquisition efforts, are centered around this unit. This choice reflects the growing recognition that activities taking place in one part of a watershed can greatly affect other parts of the watershed, and that management efficiencies are achieved when viewing the watershed holistically. At the same time, the Agency recognizes that contamination in some reaches in a watershed does not necessarily indicate that the entire watershed is affected.

Watershed management is a vital component of community-based environmental protection. The Agency and its state and federal partners can address sediment contamination problems through watershed management approaches. Watershed management programs focus on hydrologically defined drainage basins rather than areas defined by political boundaries. Local management, stakeholder involvement, and holistic assessments of water quality are characteristics of the watershed approach. The National Estuary Program is one example of the watershed approach that has led to specific actions to address contaminated sediment problems. Specifically, the Narragansett (Rhode Island) Bay, Long Island Sound, New York/New Jersey Harbor, and San Francisco Bay Estuary Programs have all recommended actions to reduce sources of toxic contaminants to sediment. Numerous other examples of watershed management programs are summarized in *The Watershed Approach: 1993/94 Activity Report* (USEPA, 1994g) and *A Phase I Inventory of Current EPA Efforts to Protect Ecosystems* (USEPA, 1995b).

Available options for reducing health and environmental risks from contaminated sediment include physical removal and land disposal; subaqueous capping; *in situ* or *ex situ* biological, physical/chemical, or thermal treatment to destroy or remove contaminants; or natural recovery through continuing deposition of clean sediment. Assuming further investigation reveals the need for management attention to reduce risks, the preferred means depends on factors such as the degree and extent of contamination, the value of the resource, the cost of available options, likely human and ecological exposure, and the acceptable time period for recovery. If risk managers anticipate a lengthy period of time prior to recovery of the system, state and local authorities can consider options such as placing a fish consumption advisory on water

bodies or portions of water bodies where a significant human health risk exists.

Some of the most significant sources of persistent and toxic chemicals have been eliminated or reduced as the result of environmental controls put into place during the past 10 to 20 years. For example, the commercial use of PCBs and the pesticides DDT and chlordane has been restricted or banned in the United States. In addition, effluent controls on industrial and municipal point source discharges and best management practices for the control of nonpoint sources have greatly reduced contaminant loadings to many of our rivers and streams.

The feasibility of natural recovery, as well as the long-term success of remediation projects, depends on the effective control of pollutant sources. Although most active sources of PCBs are controlled, past disposal and use continue to result in evaporation from some landfills and leaching from soils. The predominant continuing sources of organochlorine pesticides are runoff and atmospheric deposition from past applications on agricultural land. For other classes of sediment contaminants, active sources continue to contribute substantial environmental releases. For example, liberation of inorganic mercury from fuel burning and other incineration operations continues, as do urban runoff and atmospheric deposition of metals and PAHs. In addition, discharge limits for municipal and industrial point sources are based on either technology-based limits or state-adopted standards for protection of the water column, not necessarily for downstream protection of sediment quality. Determining the local and far-field effects of individual point and nonpoint sources on sediment quality usually requires site-specific in-depth study.

The primary recommendation of this report to Congress is to encourage further investigation and assessment of contaminated sediment. States, in cooperation with EPA and other federal agencies, should proceed with further evaluations of the 96 watersheds containing APCs. In many cases, it is likely that much additional investigation and assessment has already occurred, especially in well-known areas at risk for contamination, and some areas have been remediated. If active watershed management programs are in place, these evaluations should be coordinated within the context of current or planned actions. Future assessment efforts should focus on areas such as the 57 water body segments located within the 96 watersheds containing APCs that had 10 or more sampling stations classified as Tier 1. The purpose of these efforts should be to gather additional sediment chemistry and related biological data, and to conduct further evaluation of data to deter-

mine human health and ecological risk, to determine temporal and spatial trends, to identify potential sources of sediment contamination and determine whether potential sources are adequately controlled, and to determine whether natural recovery is a feasible option for risk reduction.

Other recommendations resulting from the NSI evaluation include the following:

- *Coordinate efforts to address sediment quality through watershed management programs.* Federal, state, and local government agencies should pool their resources and coordinate their efforts to address their common sediment contamination issues. These activities should support efforts such as the selection of future monitoring sites, the setting of priorities for reissuance of National Pollutant Discharge Elimination System (NPDES) permits and permit synchronization, pollutant trading between non-point and point sources, and total maximum daily load (TMDL) development.
 - *Incorporate a weight-of-evidence approach and measures of chemical bioavailability into sediment monitoring programs.* Future monitoring programs should specify collection of AVS and SEM measurements where metals are a concern and site-specific total organic carbon (TOC) measurements where organic chemicals are a concern. Future sediment monitoring programs
- should also collect tissue residue, biological effects, and biological community measurements as well as sediment chemistry measurements.
- *Evaluate the NSI's coverage and capabilities and provide better access to information in the NSI.* EPA should consider whether to design future evaluations of NSI data to determine the temporal trends of contamination and to identify where and why conditions are improving or worsening. EPA should consider whether to expand the NSI to provide more complete national coverage of sediment quality data. EPA should also consider increasing the number of water bodies for evaluation and expanding the suite of biological and chemical information available to evaluate each site. EPA should continue its efforts to make the NSI data and evaluation results more accessible to other agencies and to the states.
 - *Develop better monitoring and assessment tools.* EPA should continue to update the NSI evaluation methodology as new assessment tools become available and the state of the science evolves. In the context of the budget process, EPA and other federal agencies should evaluate whether to request funding to support the development of tools to better characterize the sources, fate, and effects of sediment contaminants.

Chapter 1

Introduction

What Is The National Sediment Quality Survey?

The Water Resources Development Act (WRDA) of 1992 directed the U.S. Environmental Protection Agency (EPA), in consultation with the National Oceanic and Atmospheric Administration (NOAA) and the U.S. Army Corps of Engineers, to conduct a comprehensive national survey of data regarding the quality of sediments in the United States. The Act required EPA to compile all existing information on the quantity, chemical and physical composition, and geographic location of pollutants in aquatic sediment, including the probable sources of such pollutants and identification of those sediments which are contaminated. The statute defines contaminated sediment as aquatic sediment that contains chemical substances in excess of appropriate geochemical, toxicological, or sediment quality criteria or measures, or is otherwise considered to pose a threat to human health or the environment. The Act further required EPA to report to the Congress the findings, conclusions, and recommendations of such survey, including recommendations for actions necessary to prevent contamination of aquatic sediments and to control sources of contamination. In addition, the Act requires EPA to establish a comprehensive and continuing program to assess aquatic sediment quality. As part of this continuing program, EPA must report to Congress every 2 years on the assessment's findings.

To comply with the WRDA mandate, EPA's Office of Science and Technology (OST) initiated the National Sediment Inventory (NSI). The goals of the NSI are to compile sediment quality information from available electronic databases, gather information from available electronic databases and published reports on sediment contaminant sources, develop screening-level assessment protocols to identify potentially contaminated sediment, and produce biennial reports to Congress on the incidence and severity of sediment contamination nationwide. *The Incidence and Severity of Sediment Contamination in Surface Waters of the United States* is the first of these reports to Congress. To ensure that future reports to Congress accurately reflect contemporary conditions of the Nation's sediment as science evolves, the NSI will develop into a

regularly updated, centralized assemblage of sediment quality measurements and assessment techniques.

The Incidence and Severity of Sediment Contamination in Surface Waters of the United States is presented as a four-volume series. This volume, *Volume 1: The National Sediment Quality Survey*, presents a national baseline screening-level assessment of contaminated sediment over a time period of the past 15 years using a weight-of-evidence approach. The purpose of *The National Sediment Quality Survey* is to depict and characterize the incidence and severity of sediment contamination based on the *probability* of adverse effects to human health and the environment. Information contained in this volume may be used to further investigate sediment contamination on a national, regional, and site-specific scale. Volume 2 of this series presents data summaries for watersheds that have been identified in this volume as containing areas of probable concern for sediment contamination. Volume 3 presents a screening analysis to identify probable point source contributors of sediment pollutants. Volume 4 presents a screening analysis to identify probable nonpoint contributors of sediment pollutants (in preparation for subsequent biannual reports).

For *The National Sediment Quality Survey*, OST compiled and analyzed historical data that were collected from 1980 to 1993 from across the country and are currently stored in large electronic databases. This effort required a substantial synthesis of multiple formats and the coordinated efforts of many federal and state environmental information programs that maintain relevant data. Published data that have not been entered into databases, or are not readily available to EPA, are not included in the NSI at this time and thus were not evaluated for this report to Congress. As data management systems and access capabilities continue to improve, EPA anticipates that a greater amount of data will be readily available in electronic form.

This report presents the results of the screening-level assessment of the NSI data. For this assessment, OST examined sediment chemistry data, associated fish tissue residue levels, and sediment toxicity test results. The purpose was to determine whether potential contamina-

tion problems either exist currently or existed over the past 15 years at distinct monitoring locations. This report identifies locations where available data indicate that direct or indirect exposure to the sediment could be associated with adverse effects to aquatic life or human health. However, because this analysis is based on readily available electronic data, contamination problems exist at some locations where data are lacking. Furthermore, because the data analyzed were collected over a relatively long period of time, conditions might have improved or worsened since the sediment was sampled. Consequently, this report does not definitively assess the current overall condition of all sediments across the country, but serves as a baseline for future assessments, which will include additional sampling stations, incorporate contemporary data, and examine trends.

In addition to this and future reports to Congress, EPA anticipates that products generated through the NSI will provide managers at the federal, state, and local levels with information. Many of the NSI data were obtained by local watershed managers from monitoring programs targeted toward areas of known or suspected contamination. NSI data and evaluation results can assist local watershed managers by providing additional data that they might not have, demonstrating the application of a weight-of-evidence approach for identifying and screening contaminated sediment locations, and allowing researchers to draw upon a large data set of information to conduct new analyses that ultimately will be relevant for local assessments.

The National Sediment Quality Survey summarizes national, regional, and state results from the evaluation of NSI data. Chapter 1 provides background information about sediment quality issues. Chapter 2 is an overview of the assessment methods used to evaluate the NSI data. Chapter 3 contains the evaluation results on a national, regional, and state basis. Chapter 4 presents information on probable sources of sediment contamination, including point and nonpoint sources. A discussion of the results is provided in Chapter 5. Chapter 6 presents recommendations for evaluating and managing contaminated sediments. Several appendices present detailed descriptions of both the NSI data and the approach used to evaluate the data:

- A: Detailed Description of NSI Data
- B: Description of Evaluation Parameters Used in the NSI Data Evaluation
- C: Method for Selecting Biota-Sediment Accumulation Factors and Percent Lipids in Fish

Tissue Used for Deriving Theoretical Bioaccumulation Potentials

- D: Screening Values for Chemicals Evaluated
- E: Cancer Slope Factors and Noncancer Reference Doses Used to Develop EPA Risk Levels
- F: Species Characteristics Related to NSI Bioaccumulation Data
- G: Notes on the Methodology for Evaluating Sediment Toxicity Tests
- H: Additional Analyses for PCBs and Mercury
- I: NSI Data Evaluation Approach Recommended by the National Sediment Inventory Workshop, April 26-27, 1994

Why Is Contaminated Sediment An Important National Issue?

Sediment provides habitat for many aquatic organisms and functions as an important component of aquatic ecosystems. Sediment also serves as a major repository for persistent and toxic chemical pollutants released into the environment. In the aquatic environment, chemical waste products of anthropogenic (human) origin that do not easily degrade can eventually accumulate in sediment. In fact, sediment has been described as the "ultimate sink," or storage place, for pollutants (Salomons et al., 1987). If that were entirely true, however, we would not need to be concerned about potential adverse effects from these "stored" pollutants. Unfortunately, sediment can function as both a sink and a source for contaminants in the aquatic environment.

Adverse effects on organisms in or near sediment can occur even when contaminant levels in the overlying water are low. Benthic (bottom-dwelling) organisms can be exposed to contaminants in sediment through direct contact, ingestion of sediment particles, or uptake of dissolved contaminants present in the interstitial (pore) water. In addition, natural and human disturbances can release contaminants to the overlying water, where pelagic (open-water) organisms can be exposed. Evidence from laboratory tests shows that contaminated sediment can cause both immediate lethality (acute toxicity) and long-term deleterious effects (chronic toxicity) to benthic organisms. Field studies have revealed other effects, such as tumors and other lesions, on bottom-feeding fish. These effects can reduce or eliminate species of recreational, commercial, or ecological importance (such as crabs, shrimp, and fish) in water bodies either directly or

by affecting the food supply that sustainable populations require. Furthermore, sediment contaminants might not kill the host organism, but might accumulate in edible tissue to levels that cause health risks to wildlife and human consumers.

In summary, environmental managers and others are concerned about sediment contamination and the assessment of sediment quality for the following reasons (adapted from Power and Chapman in "Assessing Sediment Quality," 1992):

- Various toxic contaminants found only in barely detectable amounts in the water column can accumulate in sediments to much higher levels.
- Sediments serve as both a reservoir for contaminants and a source of contaminants to the water column and organisms.
- Sediments integrate contaminant concentrations over time, whereas water column contaminant concentrations are much more variable and dynamic.
- Sediment contaminants (in addition to water column contaminants) affect bottom-dwelling organisms and other sediment-associated organisms, as well as both the organisms that feed on them and humans.
- Sediments are an integral part of the aquatic environment that provide habitat, feeding, spawning, and rearing areas for many aquatic organisms.

Contaminated sediments can affect aquatic life in a number of ways. Areas with high sediment contaminant levels can be devoid of sensitive species and, in some cases, all species. For example, benthic amphipods were absent from contaminated waterways in Commencement Bay, Washington (Swartz et al., 1982). In Rhode Island, the number of species of benthic molluscs was reduced near an outfall where raw electroplating wastes and other wastes containing high levels of toxic metals were discharged into Narragansett Bay (Eisler, 1995). In California, pollution-tolerant oligochaete worms dominate the sediment in the lower portion of Coyote Creek, which receives urban runoff from San Jose (Pitt, 1995).

Sediment contamination can also adversely affect the health of organisms and provide a source of contaminants to the aquatic food chain (Lyman et al., 1987). For example, fin rot and a variety of tumors have been found in

fish living above sediments contaminated by polycyclic aromatic hydrocarbons (PAHs) located near a creosote plant on the Elizabeth River in Virginia. These impacts have been correlated with the extent of sediment contamination in the river (Van Veld et al., 1990). Liver tumors and skin lesions have occurred in brown bullheads from the Black River in Ohio, which is contaminated by PAHs from a coke plant. The authors of the Black River study established a cause-and-effect relationship between the presence of PAHs in sediment and the occurrence of liver cancer in native fish populations (Baumann et al., 1987). Examples of risks to fish-eating birds and mammals posed by contaminated food chains include reproductive problems in Forster's terns on Lake Michigan near Green Bay (Kubiak et al., 1989) and on mink farms where mink were fed Great Lakes fish (Auerlich et al., 1973). In both cases, high levels of polychlorinated biphenyls (PCBs) in fish were identified as the cause of the reproductive failures. Contaminated sediments can also affect the food chain base by eliminating food sources and, in some cases, altering natural competition, which can impact the population dynamics of higher trophic levels (Burton et al., 1989; Landis and Yu, 1995).

The accumulation of contaminants in fish tissue (called bioaccumulation) and contamination of the food chain are also important human health and wildlife concerns because people and wildlife eat finfish and shellfish. In fact, the consumption of fish represents the most significant route of aquatic exposure of humans to many metals and organic compounds (USEPA, 1992a). Most sediment-related human exposure to contaminants is through indirect routes that involve the transfer of pollutants out of the sediments and into the water column or aquatic organisms. Many surface waters have fish consumption advisories or fishing bans in place because of the high concentrations of PCBs, mercury, dioxin, kepone, and other contaminants. In 1995, over 1,500 water bodies in the United States had fish consumption advisories in place, affecting all but four states. Water supplies also have been shut down because of contaminated sediments, and in some places swimming is no longer allowed.

How Significant Is The Problem?

Puget Sound was one of the first areas in the country to be studied extensively for sediment contamination. Early studies from the 1980s demonstrated fairly extensive sediment contamination, especially near major industrial embayments (Dexter et al., 1981; Long, 1982; Malins et al., 1980; Riley et al., 1981). These early assessments demonstrated that Puget Sound sediments were contaminated by many organic and inorganic chemicals, including PCBs, PAHs, and metals. Although contaminant

concentrations in sediment tended to decrease rapidly with distance from the nearshore sources, researchers also documented widespread low-level contamination in the deepwater sediments of the main basin of Puget Sound (Ginn and Pastorok, 1982). Also in the 1980s, several kinds of biological effects, including cancerous tumors, were reported in organisms from contaminated areas of Puget Sound (Becker et al., 1987).

Several recent studies conducted in other parts of the country further illustrate the significance of sediment contamination and its potential widespread impact. For example, Myers et al. (1994) investigated the relationships between hepatic lesions (liver tumors) and stomach contents, liver tissue, and bile in three species of bottom-dwelling fish captured from 27 urban and nonurban sites on the Pacific Coast from Alaska to southern California, as well as the relationship of such lesions to associated chemical concentrations in sediments. In general, the authors found that lesions were more likely to occur in fish from sites with higher concentrations of chemical contaminants in sediments. Certain lesions had a significantly higher relative risk of occurrence at urban sites in Puget Sound, San Francisco Bay, the vicinity of Los Angeles, and San Diego Bay (Myers et al., 1994). The results of this study provide strong evidence for the involvement of sediment contaminants in causing hepatic lesions in bottom fish and clearly indicate the usefulness of these lesions as indicators of contaminant-induced effects in fish (Myers et al., 1994).

Several recent assessments of existing data on the Nation's marine (saltwater) and freshwater sediments (e.g., NRC, 1989) indicate potentially widespread and serious contamination problems. The NOAA National Status and Trends Program has monitored coastal sediment contamination since the mid-1980s and has linked elevated pollutant concentrations to the potential for adverse biological effects in many urban areas, including the Hudson-Raritan estuary, Boston Harbor, western Long Island, and the Oakland estuary of San Francisco Bay (Long and Morgan, 1990; Power and Chapman, 1992). The U.S. and Canadian governments have also identified widespread contaminated sediments in the Great Lakes (IJC, 1987; Fox and Tuchman, 1996; Power and Chapman, 1992). The USEPA (1993a) summarizes other recent assessment studies. However, there is still no national-scale assessment of the incidence and severity of sediment contamination, particularly in freshwater areas. This report is the result of EPA's first assessment to determine how significant the problem of sediment contamination is on a national basis.

What Are The Potential Sources Of Sediment Contamination?

Water bodies usually receive discharges of pollutants as a result of the various human activities, past and present, that take place nearby. The cumulative effect of historical, nonpoint, and point sources can contribute to sediment contamination. A point source is a single, identifiable source of pollution such as a pipe from a factory or a wastewater treatment plant. Nonpoint source pollution is usually carried off the land by stormwater runoff and includes pollutants from agriculture, urban areas, mining, marinas and boating, construction and other land modifications, and atmospheric deposition. Many of the current suspected and documented cases of sediment contamination are caused by past industrial and agricultural uses of highly persistent and toxic chemicals, such as PCBs and chlordane. While the use of such chemicals has since been banned or tightly restricted, monitoring programs continue to study the extent and severity of their accumulation in sediment, and subsequently in the tissues of fish and shellfish. Other potential sediment contaminants, including heavy metals, PAHs, some pesticides, and existing and new industrial chemicals, continue to appear in point and nonpoint source releases. However, significant progress over the past 10 to 15 years, achieved through industry pollution prevention initiatives, National Pollutant Discharge Elimination System (NPDES) permits, and national technology-based effluent guideline limitations, has substantially reduced the discharge of toxic and persistent chemicals. Surficial sediments are often less contaminated than deeper sediments indicating improved sediment conditions with reduced discharges over the past 10 to 15 years.

The characteristics of local sediment contamination are usually related to the types of land use activities that take place or have taken place within the area that drains into the water body (the watershed). For example, harbors, streams, and estuaries bordered by industrialized or urbanized areas tend to have elevated levels of the metals and organic compounds typically associated with human activities in these land use areas. Sometimes the contamination is localized beneath an outfall of industrial or municipal waste; in other cases, natural mixing processes and dredging disperse the pollutants. In addition, rivers and streams can carry pollutants from upstream sources into larger downstream water bodies, where they can contribute further to the problem of sediment contamination. Drifting atmospheric pollutants that are eventually deposited in water bodies also contribute to sediment contamination. For example, EPA estimates that

76 to 89 percent of PCB loadings to Lake Superior have come from air pollution (USEPA, 1994a).

Point source releases, including accidental or deliberate discharges, have resulted in elevated localized sediment contamination. Purposeful and accidental contaminant additions include effluent discharges, spills, dumping, and the addition of herbicides to lakes and reservoirs. Both industrial and municipal point sources have contributed a wide variety of contaminants to sediments. Municipal point sources include sewage treatment plants and overflows from combined sewers (which mix the contents of storm sewers and sanitary sewers). Industrial point sources include manufacturing plants and power-generating operations.

The pervasiveness of organic and metal compounds in sediments near urban and agricultural areas and the association of large inputs of these contaminants with runoff events tend to support the importance of contaminant contributions from nonpoint sources like atmospheric deposition and land drainage. For example, mining is a significant source of sediment contamination in some regions, as are runoff and seepage from landfills and Superfund sites, and urban and agricultural runoff (Baudo and Muntau, 1990; Canfield et al., 1994; Hoffman, 1985; Livingston and Cox, 1985; Ryan and Cox, 1985). Agricultural runoff can contribute selenium, arsenic, and mercury and a wide variety of pesticides. Urban runoff is a frequently mentioned source of heavy metals and PAHs.

Atmospheric deposition can be one of the major sources of lead, arsenic, cadmium, mercury, PAHs, DDT and other organochlorine pesticides, and PCBs in many aquatic environments (USEPA, 1993c). However, it is often difficult to determine the portion of these contaminants contributed by nonpoint versus point source discharges because the same contaminants can come from both (Baudo and Muntau, 1990).

Kepone contamination in the James River in Virginia is an example of historical sediment contamination. Kepone is a very stable organic compound formerly used in pesticides. Although active discharges of kepone at the production site in Hopewell, Virginia, terminated in 1980, high levels of kepone can still be found in the sediment and finfish and shellfish of the James River downstream from the original discharge site (Huggett and O'Conner, 1988; Nichols, 1990). In fact, a fish advisory exists on portions of the James River because of high levels of kepone in tissues of fish taken from the river. Historical sediment contamination problems such as those on the James River are often further complicated by ongoing discharge sources. Such historical sediment contamination problems can also slow the natural recovery of aquatic systems because of the stable nature of the chemicals responsible for the contamination. Historical sediment contamination can also cause new problems. For example, during heavy storms contaminated sediments can be uncovered, resuspended, and carried downstream, where they cause problems in areas that were previously uncontaminated.

Chapter 2

Methodology

EPA faced two primary challenges to achieving the short-term goals of the National Sediment Inventory (NSI) and fulfilling the mandate of the Water Resources Development Act (WRDA) of 1992, as described in the introduction to this report. The first challenge was to compile a database of consistent sediment quality measures suitable for all regions of the country. The second challenge was to identify scientifically sound methods to determine whether a particular sediment is "contaminated," according to the definition set forth in the statute.

In many known areas of contamination, visible and relatively easy-to-recognize evidence of harmful effects on resident biota is concurrent with elevated concentrations of contaminants in sediment. In most cases, however, less obvious effects on biological communities and ecosystems are much more difficult to identify and are frequently associated with varying concentrations of sediment contaminants. In other words, bulk sediment chemistry measures are not always indicative of toxic effect levels. Similar concentrations of a chemical can produce widely different biological effects in different sediments. This discrepancy occurs because toxicity is influenced by the extent to which chemical contaminants bind to other constituents in sediment. These other sediment constituents, such as organic ligands and inorganic oxides and sulfides, are said to control the *bioavailability* of accumulated contaminants. Toxicant binding, or sorption, to sediment particles suspends the toxic mode of action in biological systems. Because the binding capacity of sediment varies, the degree of toxicity exhibited also varies for the same total quantity of toxicant.

The five general categories of sediment quality measurements are sediment chemistry, sediment toxicity, community structure, tissue chemistry, and pathology (Power and Chapman, 1992). Each of these categories has strengths and limitations for a national-scale sediment quality assessment. To be efficient in collecting usable data of similar types, EPA sought data that were available in electronic format, represented broad geographic coverage, and represented specific sampling locations identified by latitude and longitude coordinates. EPA found sediment chemis-

try and tissue chemistry to be the most widely available sediment quality measures.

As described above, sediment chemistry measures might not accurately reflect risk to the environment. However, EPA has recently developed assessment methods that combine contaminant concentration with measures of the primary binding phase to address bioavailability for certain chemical classes, under assumed conditions of thermodynamic equilibrium (USEPA, 1993d). Other methods, which rely on statistical correlations of contaminant concentrations with incidence of adverse biological effects, also exist (Barrick et al., 1988; FDEP, 1994; Long et al., 1995). In addition, fish tissue levels can be predicted using sediment contaminant concentrations, along with independent field measures of chemical partitioning behavior and other known or assigned fish tissue and sediment characteristics. EPA can evaluate risk to consumers from predicted and field-measured tissue chemistry data using established dose-response relationships and standard consumption patterns. Evaluations based on tissue chemistry circumvent the bioavailability issue while also accounting for other mitigating factors such as metabolism. The primary difficulty in using field-measured tissue chemistry is relating chemical residue levels to a specific sediment, especially for those fish species which typically forage across great distances.

Sediment toxicity, community structure, and pathology measures are less widely available than sediment chemistry and fish tissue data in the broad-scale electronic format EPA sought for the NSI. Sediment toxicity data are typically in the form of percent survival, compared to control mortality, for indicator organisms exposed to the field-sampled sediment in laboratory bioassays (USEPA, 1994b, c). Although these measures account for bioavailability and the antagonistic and synergistic effects of pollutant mixtures, they do not address possible long-term reproductive or growth effects, nor do they identify specific contaminants responsible for observed lethal toxicity. Indicator organisms also might not represent the most sensitive species. Community structure measures, such as fish abundance and benthic diversity, and pathology measures are potentially

indicative of long-term adverse effects, yet there are a multitude of mitigating physical, hydrologic, and biological factors that might not relate in any way to chemical contamination.

The ideal assessment methodology would be based on matched data sets of all five types of sediment quality measures to take advantage of the strengths of each measurement type and to minimize their collective weaknesses. Unfortunately, such a database does not exist on a national scale, nor is it typically available on a smaller scale. Based on the statutory definition of contaminated sediment in the WRDA, EPA can identify locations where sediment chemistry measures exceed "appropriate geochemical, toxicological, or sediment quality criteria or measures." Again based on the statutory definition, EPA can also use tissue chemistry and sediment toxicity measures to identify aquatic sediments that "otherwise pose a threat to human health or the environment" because there are either screening values (e.g., EPA risk levels for fish tissue consumption) or control samples for comparison. However, EPA believes it cannot accurately evaluate community structure or pathology measures to identify contaminated sediment, based on the statutory definition, without first identifying appropriate reference conditions to which measured conditions could be compared.

For this analysis, EPA evaluated sediment chemistry, tissue chemistry, and sediment toxicity data, taken at the same sampling station, individually and in combination using a variety of assessment methods. Because of the limitations of the available sediment quality measures and assessment methods, EPA characterizes this identification of contaminated sediment locations as a *screening-level* analysis. Similar to a potential human illness screen, a screening-level analysis should pick up potential problems and note them for further study. A screening-level analysis will typically identify many potential problems that prove not to be significant upon further analysis. Thus, classification of sampling stations in this analysis is not meant to be definitive, but is intended to be inclusive of potential problems arising from persistent metal and organic chemical contaminants. For this reason, EPA elected to evaluate data collected from 1980 to 1993 and to evaluate each chemical or biological measurement taken at a given sampling station individually. A single measurement of a chemical at a sampling station, taken at any point in time over the past 15 years, may have been sufficient to classify the sampling station as having an increased probability of association with adverse effects to aquatic life or human health.

EPA recognizes that sediment is dynamic and that great temporal and spatial variability in sediment quality exists. This variability can be a function of sampling (e.g., a contaminated area might be sampled one year, but not the next) or a function of natural events (e.g., floods can move contaminated sediment from one area to another, or can bury contaminated sediment). Movement of sediment is highly temporal, and dependent upon the physical and biological processes at work in the watershed. Some deposits will redistribute while others will remain static unless disturbed by extreme events.

In this report, EPA associates sampling stations with their "probability of adverse effects on aquatic life or human health." Each sampling station falls into one of three categories (tiers): associated adverse effects are probable (Tier 1); associated adverse effects are possible, but expected infrequently (Tier 2); or no indication of associated adverse effects (Tier 3). A Tier 3 sampling station classification does not necessarily imply a zero or minimal probability of adverse effects, only that available data (which may be substantial or limited) do not indicate an increased probability of adverse effects. Recognizing the imprecise nature of the numerical assessment parameters, Tier 1 sampling stations are distinguished from Tier 2 sampling stations based on the magnitude of a sediment chemistry measure or the degree of corroboration among the different types of sediment quality measures.

The remainder of this chapter presents a short history of how EPA developed the NSI, a brief description of the NSI data, and an explanation of the NSI data evaluation approach.

Background

EPA initiated work several years ago on the development of the NSI through pilot inventories in EPA Regions 4 and 5 and the Gulf of Mexico Program. Based on lessons learned from these three pilot inventories, the Agency developed a document entitled *Framework for the Development of the National Sediment Inventory* (USEPA, 1993a), which describes the general format for compiling sediment-related data and provides a brief summary of sediment quality evaluation techniques. The format and overall approach were then presented, modified slightly, and agreed upon at an interagency workshop held in March 1993 in Washington, DC. Following the workshop, EPA began compiling and evaluating data for the NSI. Data from several national and regional databases were included as part of the effort.

In the spring of 1994, EPA conducted a preliminary evaluation of NSI sediment chemistry data only. The purpose of the assessment was to identify sampling stations throughout the United States where measured values of sediment pollutants exceeded sediment chemistry levels of concern. The results of that assessment were then distributed to the EPA Regional offices for their review. The Regional offices were asked to review the preliminary evaluation and to:

- Verify sampling stations targeted as areas of concern.
- Identify sampling stations that might be incorrectly targeted as areas of concern.
- Identify potential areas of concern that were not targeted, but should have been.
- Inform EPA Headquarters of additional sediment quality data that should be included in the NSI to make the inventory more accurate and complete.

The EPA Regional offices completed their review of the preliminary evaluation during the winter of 1994-95. Regional comments on the results of the preliminary evaluation were incorporated into the NSI database. EPA will add new data sets identified by the Regions to the NSI and include them in the national assessment for future reports to Congress.

In April 1994, EPA Headquarters held the Second National Sediment Inventory Workshop (USEPA, 1994d). The purpose of this workshop was to bring together experts in the field of sediment quality assessment to recommend an approach for integrating and evaluating the sediment chemistry and biological data contained in the NSI. The final approach recommended by workshop participants provided the basis for the final approach adopted to evaluate NSI data for this report to Congress. Appendix I of this report provides a brief description of the workshop approach and a list of attendees.

Description of NSI Data

The NSI includes data from the following data storage systems and monitoring programs:

- Selected data sets from EPA's Storage and Retrieval System (STORET) (69 percent of sampling stations)

- U.S. Army Corps of Engineers (USACE)
- U.S. Geological Survey (USGS)
- EPA
- States
- NOAA's Coastal Sediment Inventory (COSED) (5 percent of sampling stations)
- EPA's Ocean Data Evaluation System (ODES) (6 percent of sampling stations)
- EPA Region 4's Sediment Quality Inventory (5 percent of sampling stations)
- Gulf of Mexico Program's Contaminated Sediment Inventory (1 percent of sampling stations)
- EPA Region 10/COE Seattle District's Sediment Inventory (8 percent of sampling stations)
- EPA Region 9's Dredged Material Tracking System (DMATS) (1 percent of sampling stations)
- EPA's Great Lakes Sediment Inventory (less than 1 percent of sampling stations)
- EPA's Environmental Monitoring and Assessment Program (EMAP) (2 percent of sampling stations)
- USGS (Massachusetts Bay) Data (3 percent of sampling stations)

Although EPA elected to evaluate data collected since 1980 (i.e., 1980-93), data from before 1980 are still maintained in the NSI. At a minimum, EPA required that electronically available data include monitoring program, sampling date, latitude and longitude coordinates, and measured units for inclusion in the NSI. Additional data fields providing details such as sampling method or other quality assurance/quality control information were retained in the NSI if available. Additional information about available data fields and NSI component databases is presented in Appendix A of this report.

The types of data contained in the NSI include the following:

- *Sediment chemistry*: Measurement of the chemical composition of sediment-associated contaminants.
- *Tissue residue*: Measurement of chemical contaminants in the tissues of organisms.

- *Benthic abundance*: Measurement of the number and types of organisms living in or on sediments.
- *Toxicity*: Measurement of the lethal or sublethal effects of contaminants in environmental media on various test organisms.
- *Histopathology*: Observation of abnormalities or diseases in tissue (e.g., tumors).
- *Fish abundance*: Measurement of the number and types of fish found in a water body.

The NSI represents a compilation of environmental monitoring data from a variety of sources. Most of the component databases are maintained under known and documented quality assurance and quality control procedures. However, EPA's STORET database is intended to be a broad-based repository of data. Consequently, the quality of the data in STORET, both in terms of database entry and analytical instrument error, is unknown and probably varies a great deal depending on the quality assurance management associated with specific data submittals.

Inherent in the diversity of data sources are contrasting monitoring objectives and scope. Component sources contain data derived from different spatial sampling plans, sampling methods, and analytical methods. For example, most data from EPA's EMAP program represent sampling stations that lie on a standardized grid over a given geographic area, whereas data in EPA's STORET most likely represent state monitoring data sampled from locations near known discharges or thought to have elevated contaminant levels. In contrast, many of the National Status and Trends Program data in NOAA's COSED database represent sampling stations purposely selected because they are removed from known discharges. However, many other sampling stations in the COSED database were located within highly urbanized bays and estuaries where chemical contamination was expected. These sampling stations include data from regional bioeffects assessments in which NOAA examined sediment quality in several highly urbanized areas. These surveys were region-wide assessments, not point source or end-of-pipe studies.

From an assessment point of view, STORET data might be useful for developing a list of contaminated sediment locations, but might overstate the general extent of contaminated sediment in the Nation by focusing largely on areas most likely to be problematic. On the other hand, analysis of EMAP data might result in a more

balanced assessment in terms of the mix of contaminated sampling stations and uncontaminated sampling stations. Approximately two-thirds of sampling stations in the NSI are from the STORET database. Reliance on these data is consistent with the stated objective of this survey: to identify those sediments which are contaminated. However, one cannot accurately make inferences regarding the overall condition of the Nation's sediment, or characterize the "percent contamination," using the data in the NSI because uncontaminated areas are most likely substantially underrepresented.

NSI data do not evenly represent all geographic regions in the United States, nor do the data represent a consistent set of monitored chemicals. For example, several of the databases are targeted toward marine environments or other geographically focused areas. Table 2-1 presents the number of stations evaluated per state. More than 50 percent of all stations evaluated in the NSI are located in Washington, Florida, Illinois, California, Virginia, Ohio, Massachusetts, and Wisconsin. Each of these states has more than 700 monitoring stations. Other states of similar or larger size (e.g., Georgia, Pennsylvania) have far fewer sampling stations with data for evaluation. Figures 2-1, 2-2, and 2-3 depict the location of monitoring stations with sediment chemistry, tissue residue, and toxicity data, respectively. Individual stations may vary considerably in terms of the number of chemicals monitored. Some stations have data that represent a large number of organic and inorganic contaminants, whereas others have measured values for only a few chemicals. Thus, the inventory cannot be considered comprehensive even for locations with sampling data. The reliance on readily available electronic data has undoubtedly led to exclusions of a vast amount of information available from sources such as local and state governments and published reports. Other limitations, including data quality issues, are discussed in Chapter 5 of this report.

NSI Data Evaluation Approach

The methodology developed for classifying sampling stations according to the probability of adverse effects on aquatic life and human health from sediment contamination relies on measures of sediment chemistry, sediment toxicity, and contaminant residue in tissue. Although the NSI also contains benthic abundance, histopathology, and fish abundance data, these types of data were not used in the evaluation. Benthic and fish abundance cannot be directly associated with sediment contamination based on the statutory definition and currently available assessment tools, and available fish liver histopathology data were very limited.

Table 2-1. Number of Stations Evaluated in the NSI by State

Region 1	Connecticut	98	Region 6	Arkansas	107
	Maine	55		Louisiana	460
	Massachusetts	895		New Mexico	101
	New Hampshire	7		Oklahoma	286
	Rhode Island	42		Texas	662
	Vermont	5			
Region 2	New Jersey	448	Region 7	Iowa	228
	New York	618		Kansas	203
	Puerto Rico	30		Missouri	327
		Nebraska		253	
Region 3	Delaware	218	Region 8	Colorado	202
	District of Columbia	4		Montana	38
	Maryland	206		North Dakota	161
	Pennsylvania	311		South Dakota	43
	Virginia	1,051		Utah	47
	West Virginia	120		Wyoming	44
Region 4	Alabama	477	Region 9	Arizona	124
	Florida	1,776		California	1,443
	Georgia	318		Hawaii	36
	Kentucky	249		Nevada	96
	Mississippi	318			
	North Carolina	612			
	South Carolina	563			
Tennessee	646				
Region 5	Illinois	1,669	Region 10	Alaska	267
	Indiana	108		Idaho	95
	Michigan	402		Oregon	291
	Minnesota	438		Washington	2,225
	Ohio	970			
	Wisconsin	703			

The approach used to evaluate the NSI data focuses on the protection of benthic organisms from exposure to contaminated sediments and the protection of humans from the consumption of fish that bioaccumulate contaminants from sediment. In addition, potential effects on wildlife from fish consumption were also evaluated. The wildlife results were not included in the overall results of the NSI data evaluation; however, they are presented separately. Table 2-2 presents the classification scheme used in the evaluation of the NSI data. Each component, or evaluation parameter, of the classification scheme is numbered on Table 2-2. Each evaluation parameter is discussed under a section heading cross-referenced to these numbers. Figures 2-4 through 2-8 depict the evaluation parameters and sampling station classifications in flowchart format.

EPA analyzed the NSI data by evaluating each parameter in Table 2-2 on a measurement-by-measurement and sampling station-by-sampling station basis. Each sampling station was associated with a "probability of adverse ef-

fects" by combining parameters as shown in Table 2-2 and Figures 2-4 through 2-8. Because each individual measurement was considered independently (except for divalent metals, whose concentrations were summed), a single observation of elevated concentration could place a sampling station into Tier 1, (associated adverse effects are probable). In general, the methodology was constructed such that a sampling station classified as Tier 1 must be represented by a relatively large set of data or by a highly elevated sediment concentration of a chemical whose effects screening level is well characterized based on multiple assessment techniques. Fewer data were required to classify a sampling station as Tier 2. Any sampling station not meeting the requirements to be classified as Tier 1 or Tier 2 was classified as Tier 3. Sampling stations in this category include those for which substantial data were available without evidence of adverse effects, as well as sampling stations for which limited data were available to determine the potential for adverse effects.

Individual evaluation parameters, applied to various measurements independently, could lead to different site classifications. If one evaluation parameter indicated Tier 1, but other evaluation parameters indicated Tier 2 or Tier 3, a Tier 1 classification was assigned to the sampling station. For example, if a sampling station was categorized as Tier 2 based on all sediment chemistry data, but was categorized as Tier 1 based on toxicity data, the station was placed in Tier 1. This principle also applies to evaluating multiple contaminants within the same evaluation parameter. For example, if the evaluation of sediment chemistry data placed a sampling station in Tier 1 for metals and in Tier 2 for PCBs, the station was placed in Tier 1.

Recognizing the imprecise nature of some assessment parameters used in this report, Tier 1 sampling stations are distinguished from Tier 2 sampling stations based on the magnitude of a contaminant concentration in sediment, or the degree of corroboration among the different types of sediment quality measures. In response to uncertainty in both biological and chemical measures of sediment contamination, environmental managers must balance Type I errors (false positives: sediment classified as posing a threat that does not) with Type II errors (false negatives: sediment that poses a threat but was not classified as such). In

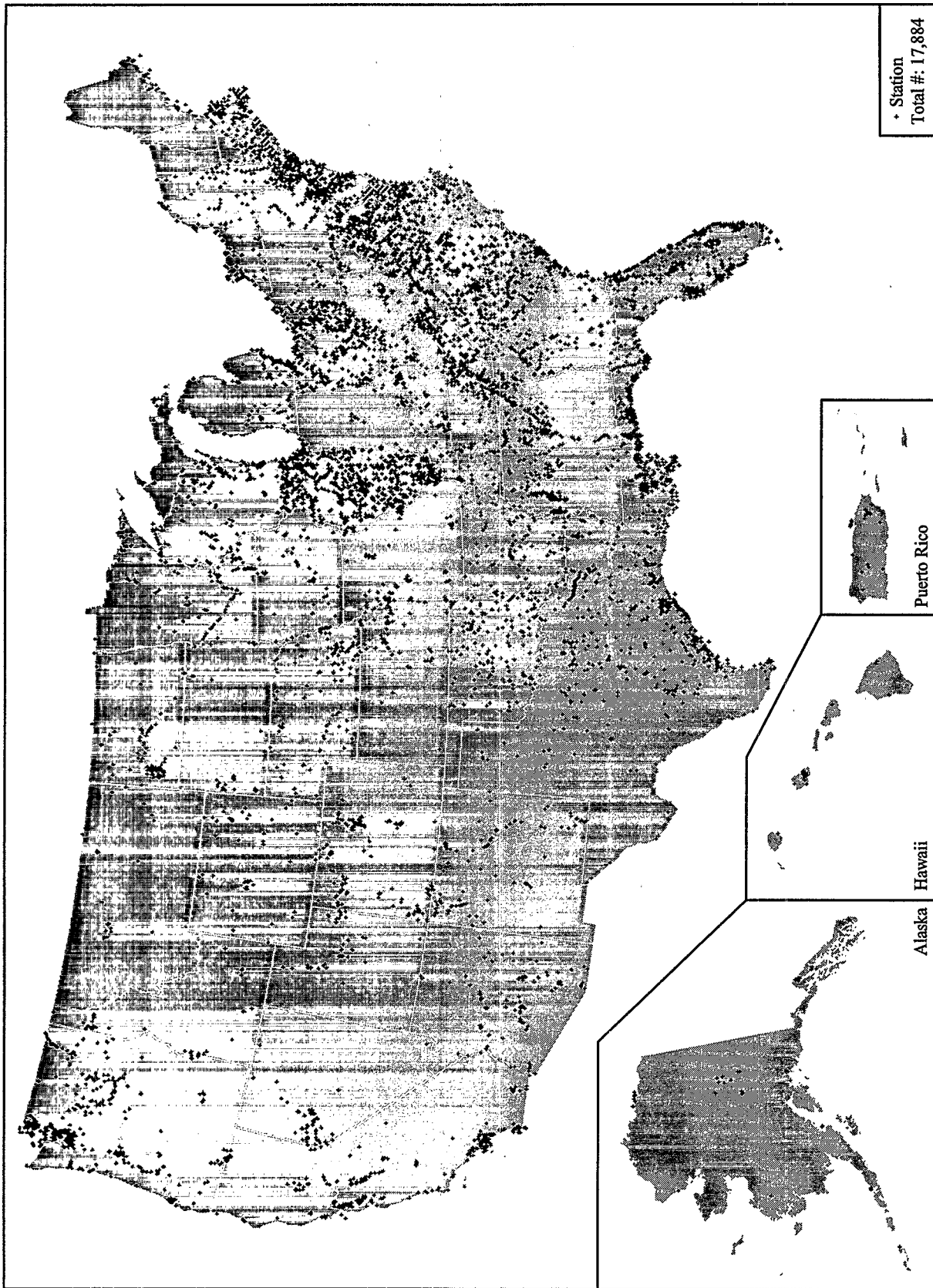

Figure 2-1. NSI Sediment Sampling Stations Evaluated.

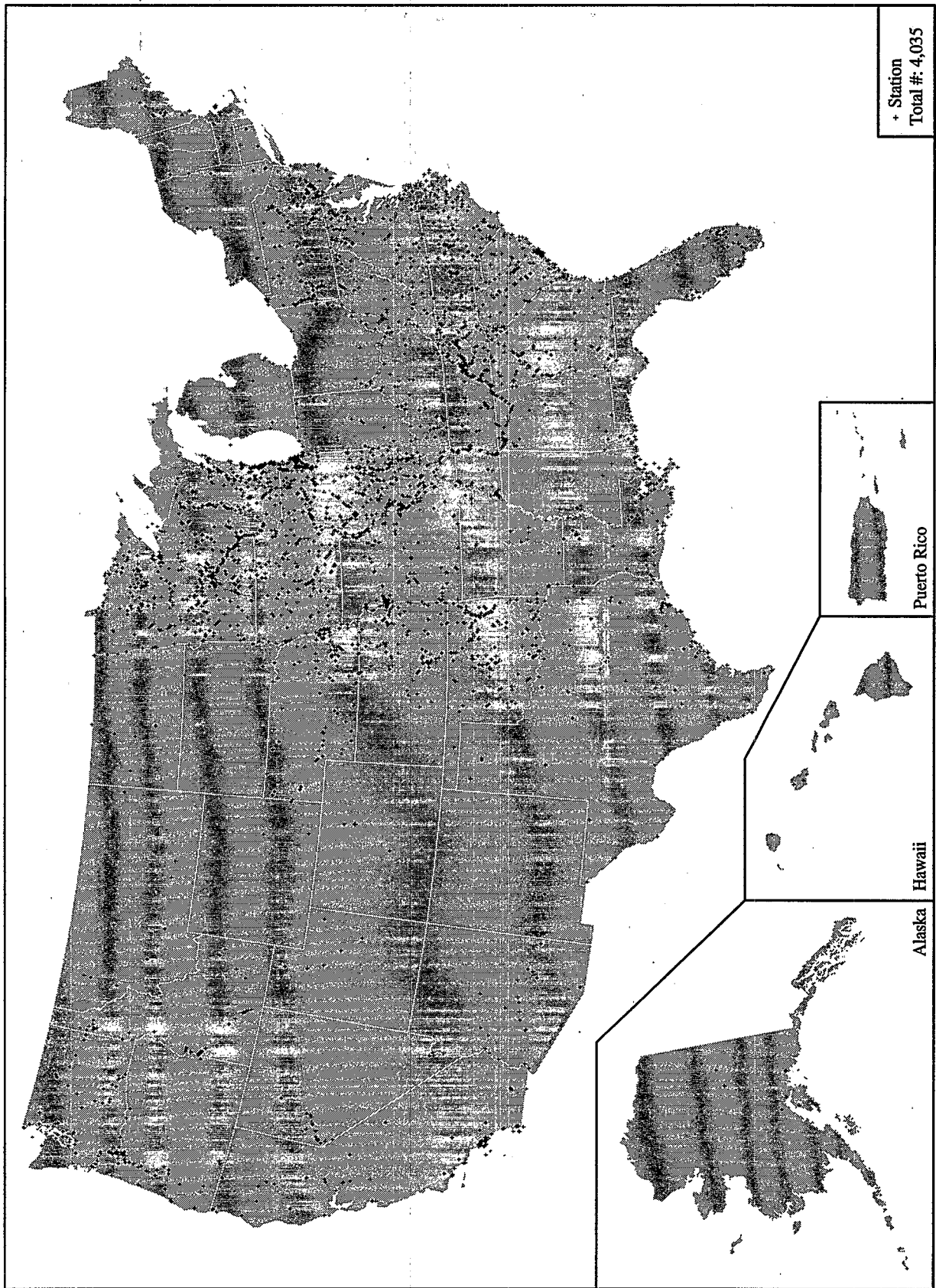

Figure 2-2. NSI Tissue Residue Sampling Stations Evaluated.

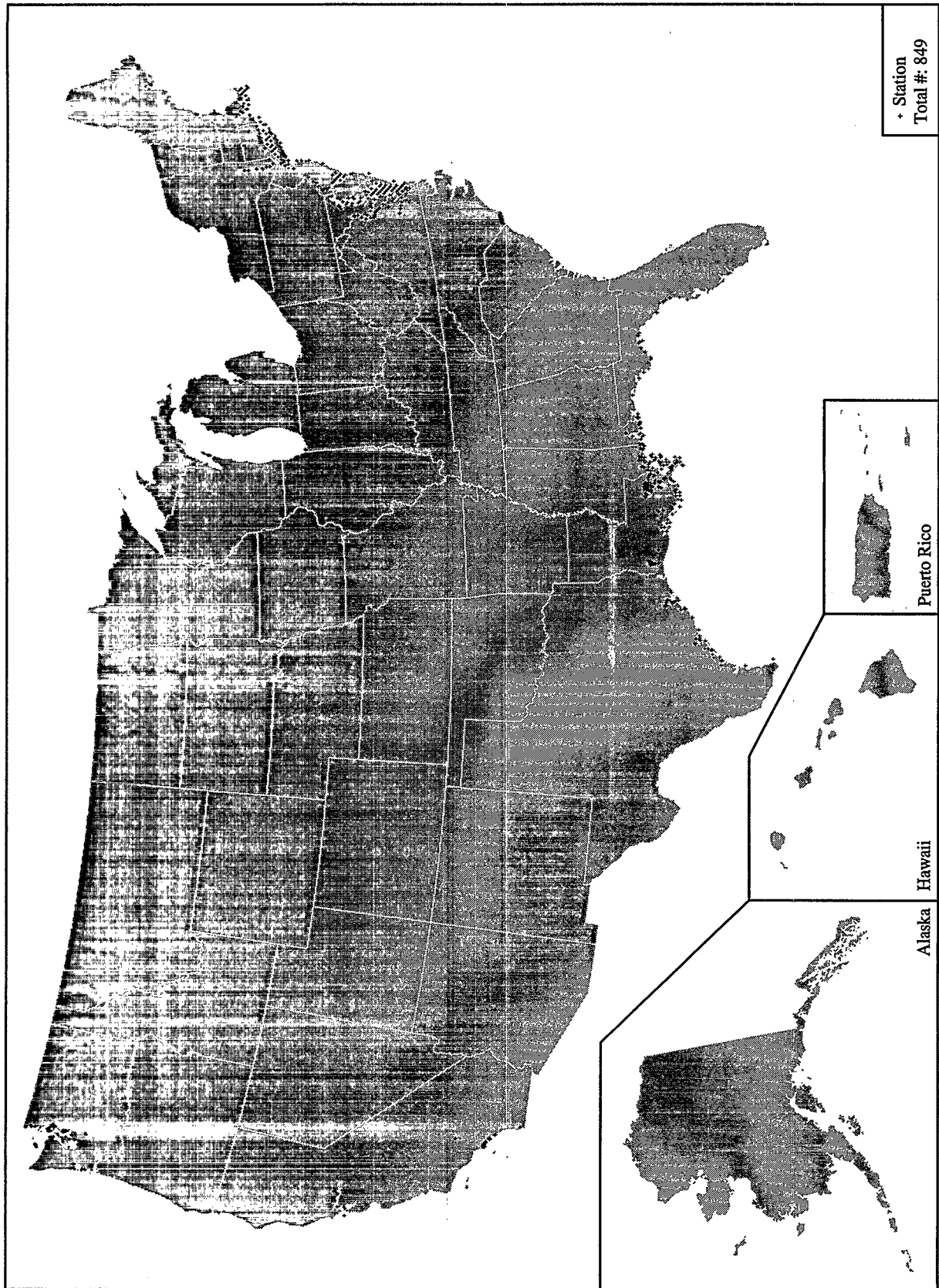

Figure 2-3. NSI Toxicity Test Stations Evaluated.

Table 2-2. NSI Data Evaluation Approach (with numbered parameters)

Category of Sampling Station Classifications	Data Used to Determine Classifications			
	Sediment Chemistry		Tissue Residue	Toxicity
Tier 1: Associated Adverse Effects to Aquatic Life or Human Health are Probable	Sediment chemistry values exceed draft sediment quality criteria for any one of the five chemicals for which criteria have been developed by EPA (must have measured TOC) 1	OR	Tissue levels of dioxin or PCBs in resident species exceed EPA risk levels 8	Toxicity demonstrated by two or more nonmicrobial acute toxicity tests using two different species (one of which must be a soft-phase test) 11
	OR [SEM]-[AVS]>5 for the sum of molar concentrations of Cd, Cu, Ni, Pb, and Zn ^a 2			
	OR Sediment chemistry values exceed two or more of the relevant upper screening values (ERMs, AETs (high), PELs, SQALs, SQCs) for any one chemical (other than Cd, Cu, Ni, Pb, and Zn) (can use default TOC) 3			
	OR Sediment chemistry TBP exceeds FDA levels or EPA risk levels 4	AND	Tissue levels in resident species exceed FDA levels or EPA risk levels 9	---
Tier 2: Associated Adverse Effects to Aquatic Life or Human Health are Possible, but Expected Infrequently	[SEM]-[AVS] = 0 to 5 for the sum of molar concentrations of Cd, Cu, Ni, Pb, and Zn 5	OR	Tissue levels in resident species exceed FDA levels or EPA risk levels 10	Toxicity demonstrated by a single-species nonmicrobial toxicity test 12
	OR Sediment chemistry values exceed any one of the relevant lower screening values (ERLs, AETs (low), TELs, SQALs, SQCs) for any one chemical (can use default TOC) 6			
	OR Sediment chemistry TBP exceeds FDA levels or EPA risk levels 7			
Tier 3: No Indication of Associated Adverse Effects	Any sampling station not categorized as Tier 1 or Tier 2. Available data (which may be very limited or quite extensive) do not indicate a likelihood of adverse effects to aquatic life or human health.			

^aMetals: Cd = cadmium, Cu = copper, Ni = nickel, Pb = lead, Zn = zinc.

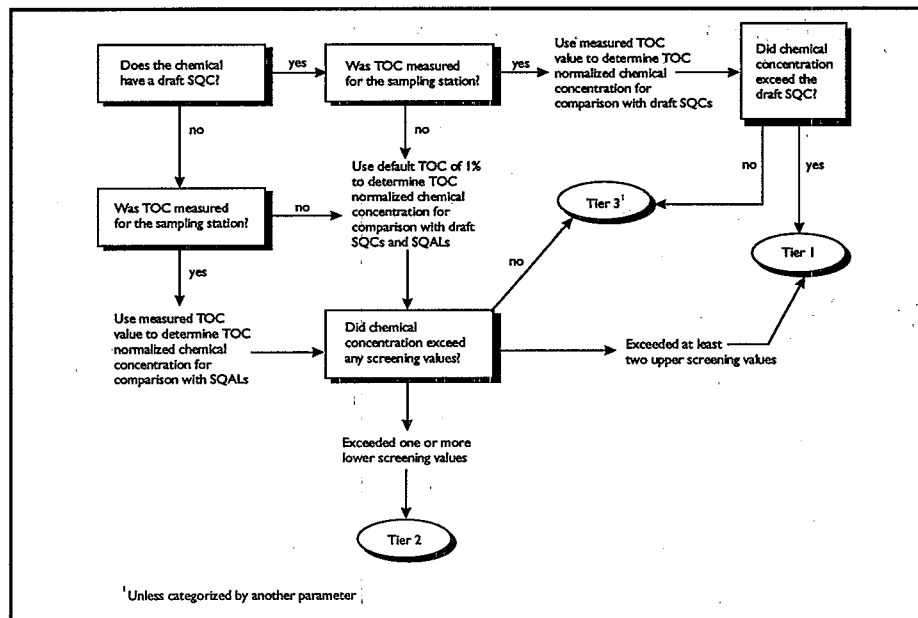

Figure 2-4. Aquatic Life Assessments: Sediment Chemistry Analysis for Organic Chemicals and Metals Not Included in the AVS Analysis.

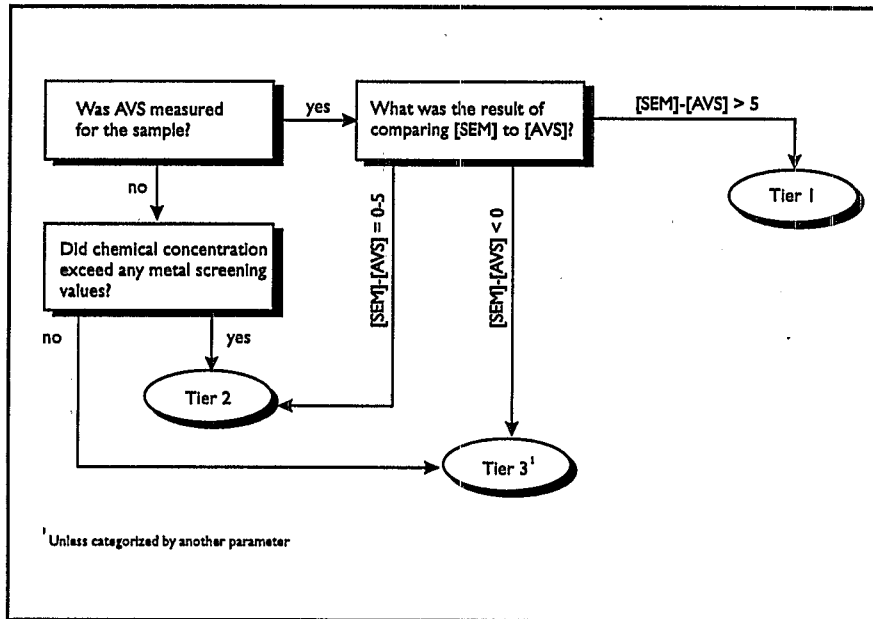

Figure 2-5. Aquatic Life Assessments: Sediment Chemistry Analysis for Divalent Metals.

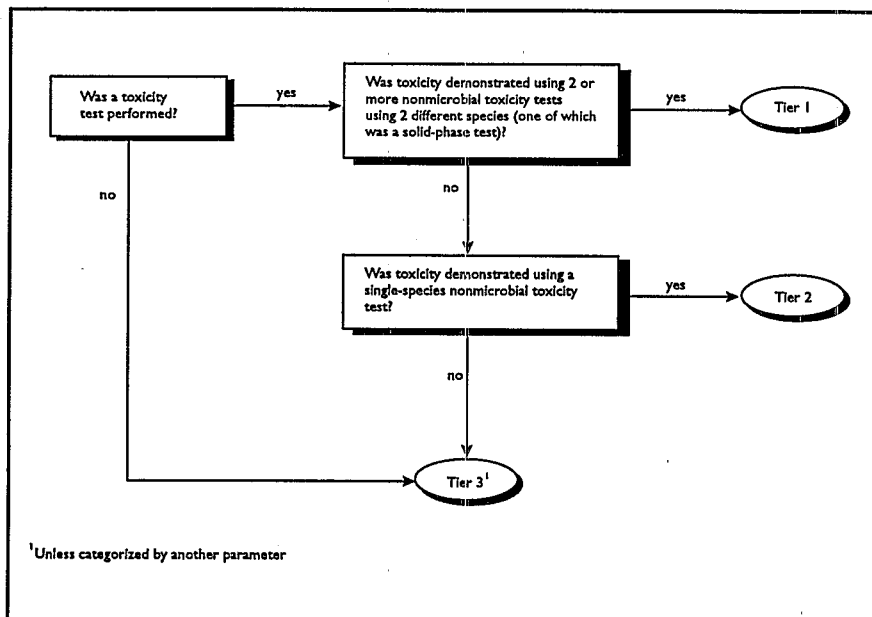

Figure 2-6. Aquatic Life Assessments: Sediment Toxicity Analysis.

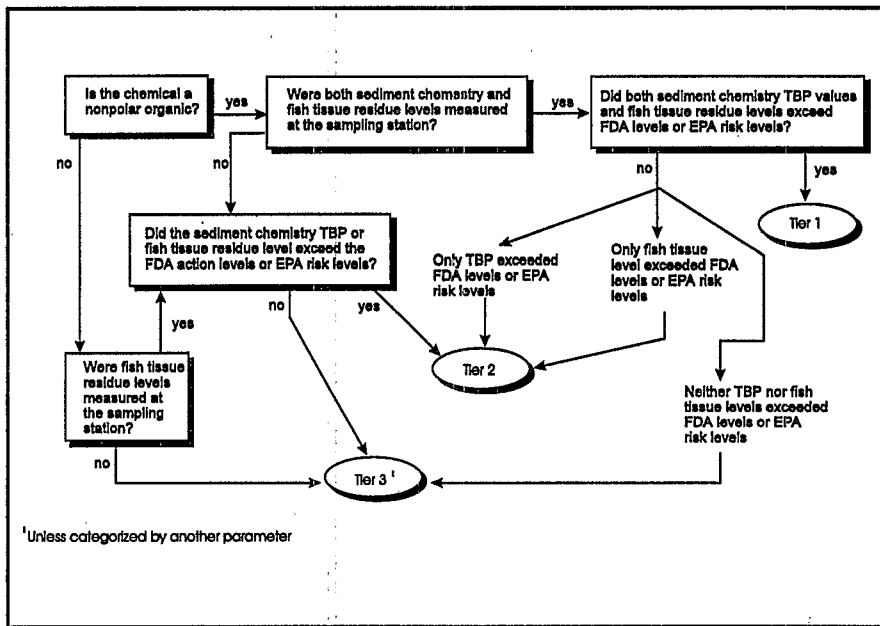

Figure 2-7. Human Health Assessments: Sediment Chemistry and Fish Tissue Residue Analysis (excluding dioxins and PCBs).

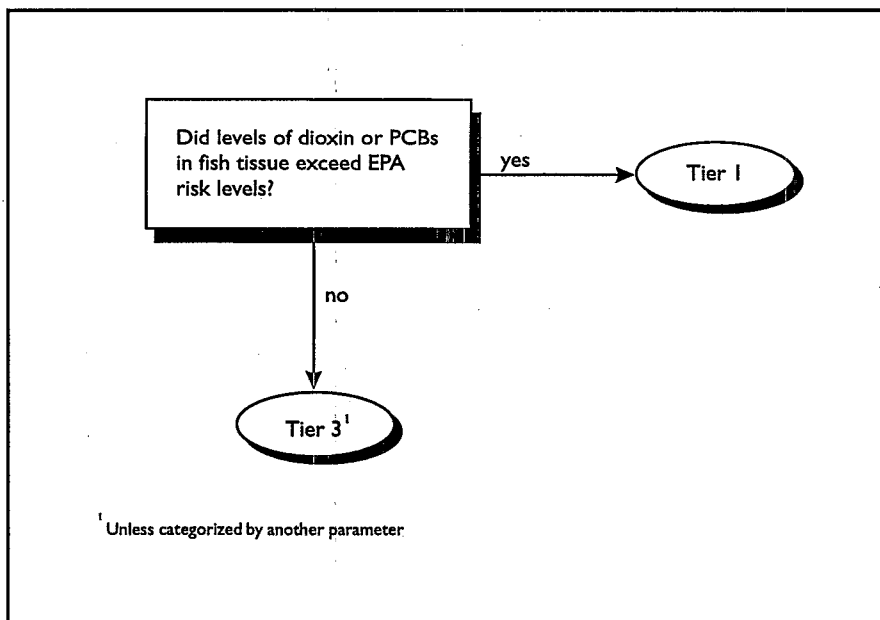

Figure 2-8. Human Health Assessments: PCBs and Dioxin in Fish Tissue Analysis.

screening analyses, the environmentally protective approach is to minimize Type II errors, which leave toxic sediment unidentified. To achieve a balance and to direct attention to areas most likely to be associated with adverse effects, Tier 1 sampling stations are intended to have a high rate of "correct" classification (e.g., sediment definitely posing or definitely not posing a threat) and a balance between Type I and Type II errors. On the other hand, to retain a sufficient degree of environmental conservatism in screening, Tier 2 sampling stations are intended to have a very low number of false negatives in exchange for a large number of false positives.

The numbered evaluation parameters used in the NSI data evaluation are briefly described below. A detailed description of the evaluation parameters is presented in Appendix B.

Sediment Chemistry Data

The sediment chemistry screening values used in this report are not regulatory criteria, site-specific cleanup standards, or remediation goals. Sediment chemistry screening values are reference values above which a sediment ecotoxicological assessment might indicate a potential threat to aquatic life. The sediment chemistry screening values used to evaluate the NSI data for potential adverse effects of sediment contamination on aquatic life include both theoretically and empirically based values. The theoretically based values rely on the physical/chemical properties of sediment and chemicals to predict the level of contamination that would not cause an adverse effect on aquatic life. The empirically based, or correlative, screening values rely on paired field and laboratory data to relate incidence of observed biological effects to the dry-weight sediment concentration of a specific chemical.

The theoretically based screening values used as parameters in the evaluation of NSI data include the sediment quality criteria, sediment quality advisory levels, and comparison of simultaneously extracted metals to acid-volatile sulfide concentrations. Empirically based, correlative screening values used in the NSI evaluation include the effects range-median/effects range-low values, probable effects levels/threshold effects levels, and apparent effects thresholds. The use of each of these screening values in the evaluation of the NSI data is described below. Another theoretically based evaluation parameter, the theoretical bioaccumulation potential (which was used for human health assessments), is also described below. The limitations associated with the use of these screening values are discussed in Chapter 5.

Sediment Chemistry Values Exceed EPA Draft Sediment Quality Criteria [1]

This evaluation parameter was used to assess the potential effects of sediment contamination on benthic species. EPA has developed draft sediment quality criteria (SQC) for the following five nonionic organic chemicals:

- Acenaphthene (polynuclear aromatic hydrocarbon, or PAH)
- Dieldrin (pesticide)
- Endrin (pesticide)
- Fluoranthene (PAH)
- Phenanthrene. (PAH)

EPA developed these draft criteria using the equilibrium partitioning (EqP) approach (described in detail in Appendix B) for linking bioavailability to toxicity. The EqP approach involves predicting the dry-weight concentration of a contaminant in sediment that is in equilibrium with a pore water concentration that is protective of aquatic life. It combines the water-only effects concentration (the chronic water quality criteria) and the organic carbon partitioning coefficient of the chemical normalized to the organic carbon content of the sediment. The draft criterion is compared to the measured dry-weight sediment concentration of the chemical normalized to sediment organic carbon content. If the organic-carbon-normalized concentration of the contaminant does not exceed the draft sediment quality criterion, adverse effects should not occur to at least 95 percent of benthic organisms. The draft SQCs are based on the highest quality data available, which have been reviewed extensively.

For the NSI data evaluation, sediment chemistry measurements with accompanying measured total organic carbon (TOC) values can place a site in Tier 1 based exclusively on a comparison with a draft SQC. The amount of TOC in sediment is one of the factors that determines the extent to which a nonionic organic chemical is bound to the sediment and, thus, the availability for uptake by organisms (bioavailability). If draft SQCs based on measured TOC were not exceeded, or if none of the five nonpolar organic chemicals that have been assigned draft SQC values were measured, the sampling station was classified as Tier 3 unless otherwise categorized by another parameter. Appendix B discusses the assumptions

and limitations associated with the use of draft SQCs. If a sample for any of the five contaminants for which draft SQCs have been developed did not have accompanying TOC data, the measured concentration was compared to the draft SQC based on a default TOC value of 1 percent. In these instances, the draft SQC was treated like other sediment quality screening values described later in this section.

The assumption that the percent TOC for samples without measured TOC is equal to 1 percent is based on a review of values published in the literature. TOC can range from 0.1 percent in sandy sediments to 1 to 4 percent in silty harbor sediments and 10 to 20 percent in navigation channel sediments (Clarke and McFarland, 1991). Long et al. (1995) reported an overall mean TOC concentration of 1.2 percent from data compiled from 350 publications for their biological effects database for marine and estuarine sediments. Ingersoll et al. (1996) reported a mean TOC concentration of 2.7 percent for inland freshwater samples. Based on this review of TOC data, EPA selected a default TOC value of 1 percent for the NSI evaluation. Consistent with the screening level application, this value should not lead to an underestimate of the bioavailability of associated contaminants in most cases.

Comparison of AVS to SEM Molar Concentrations [2, 5]

The use of the total concentration of a trace metal in sediment as a measure of its toxicity and its ability to bioaccumulate is problematic because different sediments exhibit different degrees of bioavailability for the same total quantity of metal (Di Toro et al., 1990; Luoma, 1983). These differences have recently been reconciled by relating organism toxic response (mortality) to the metal concentration in the sediment interstitial water (Adams et al., 1985; Di Toro et al., 1990). Acid-volatile sulfide (AVS) is one of the major chemical components that control the activities and availability of metals in interstitial waters of anoxic (lacking oxygen) sediments (Meyer et al., 1994).

A large reservoir of sulfide exists as iron sulfide in anoxic sediment. Sulfide will react with several divalent transition metal cations (cadmium, copper, mercury, nickel, lead, and zinc) to form highly insoluble compounds that are not bioavailable (Allen et al., 1993). It follows in theory, and with verification (Di Toro et al., 1990), that divalent transition metals will not begin to cause toxicity in anoxic sediment until the reservoir of sulfide is used up (i.e., the molar concentration of metals exceeds the molar concentration of sulfide), typically

at relatively high dry-weight metal concentrations. This observation has led to a laboratory measurement technique of calculating the difference between simultaneously extracted metal (SEM) concentration and acid volatile sulfide concentration from field samples to determine potential toxicity.

To evaluate the potential effects of metals on benthic species, the molar concentration of AVS ([AVS]) was compared to the sum of SEM molar concentrations ([SEM]) for five metals: cadmium, copper, nickel, lead, and zinc. Mercury was excluded from AVS comparison because other important factors play a major role in determining the bioaccumulation potential of mercury in sediment. Specifically, under certain conditions mercury binds to an organic methyl group and is readily taken up by living organisms.

Sediment with measured [SEM] in excess of [AVS] does not necessarily exhibit toxicity. This is because other binding phases can tie up metals. However, research indicates that sediment with [AVS] in excess of [SEM] will not be toxic from metals, and the greater the [SEM]-[AVS] difference, the greater the likelihood of toxicity from metals. Analysis of toxicity data for freshwater and saltwater sediment amphipods (crustaceans) from EPA's Environmental Research Laboratory in Narragansett, Rhode Island, revealed that 80 to 90 percent of the sediments were toxic at [SEM]-[AVS] > 5 (Hansen, 1995; see also Hansen et al., 1996). Thus, EPA selected [SEM]-[AVS] = 5 as the demarcation line between Tier 1 and Tier 2. For the purpose of this evaluation, where [SEM]-[AVS] was greater than 5, the sampling station was classified as Tier 1. If [SEM]-[AVS] was between zero and 5, the sampling station was classified as Tier 2. If [SEM]-[AVS] was less than zero, or if AVS or the five AVS metals were not measured at the sampling station, the sampling station was classified as Tier 3 unless otherwise classified by another parameter. Appendix B discusses the assumptions and limitations associated with the [SEM]-[AVS] approach.

Sediment Chemistry Values Exceed Screening Values [3, 6]

Several sets of sediment contaminant screening values, developed using different methodologies, are available to assess potential adverse effects on benthic species. The screening values selected for comparison with measured sediment levels are the draft SQCs using a default TOC of 1 percent (for those samples which do not have accompanying TOC data), sediment quality advisory levels (SQALs) for freshwater aquatic life (developed using the equilibrium partitioning approach discussed previ-

ously for the development of draft SQCs), the effects range-median (ERM) and effects range-low (ERL) values developed by Long et al. (1995), the probable effects levels (PELs) and threshold effects levels (TELs) developed for the Florida Department of Environmental Protection (FDEP, 1994), and the apparent effects thresholds (AETs) developed by Barrick et al. (1988). The assumptions and approaches used to develop these screening values are discussed in detail in Appendix B.

The draft SQCs and SQALs were both developed using the same EqP approach. However, the data used to derive SQALs were not compiled from an exhaustive literature search, nor were the toxicity data requirements as extensive as specified for draft SQCs. Toxicity values used for SQAL development include final chronic values from EPA ambient freshwater quality criteria and secondary chronic values derived using EPA's Great Lakes Water Quality Initiative "Tier II" water quality criteria methodology. The data used to develop the latter values were taken primarily from quality-screened studies in published literature. The development of SQALs is discussed in further detail in Appendix B of this report. EPA has also prepared a document describing the derivation of the SQALs (USEPA, 1996). The chemicals for which SQALs have been developed are identified in Appendix D of this volume.

The ERLs/ERMs, PELs/TELs, and AETs relate the incidence of adverse biological effects to the sediment concentration of a specific chemical at a specific sampling station using paired field and laboratory data. The developers of the ERLs/ERMs define sediment concentrations below the ERL as being in the "minimal-effects range," values between the ERL and ERM in the "possible-effects range," and values above the ERM in the "probable-effects range." In the FDEP (1994) approach, the lower of the two guidelines for each chemical (the TEL) is assumed to represent the concentration below which toxic effects rarely occur. In the range of concentrations between the TEL and PEL, effects occasionally occur. Toxic effects usually or frequently occur at concentrations above the upper guideline (the PEL).

In independent analyses of the predictive abilities of the ERL/ERMs and TEL/PELs, the percentages of samples indicating high toxicity in laboratory bioassays of amphipod survival were relatively low (10-12 percent) when all chemical concentrations were in the minimal effects range, intermediate (17-19 percent) in the possible effects range, and higher (38-42 percent) in the probable effects range. Furthermore, the percentages of samples indicating high toxicity in any one of a battery of 2-4 tests performed, including more sensitive bioas-

says with sublethal endpoints, were 5-28 percent, 59-64 percent, and 78-80 percent among samples within the minimal, possible, and probable effects ranges (Long et al., in press).

The AET approach is not based on the probability of incidence of adverse biological effects. The AET is the highest concentration at which statistically significant differences in observed adverse biological effects from reference conditions do not occur, provided that the concentration also is associated with observance of a statistically significant difference in adverse biological effects. Essentially, this identifies the concentration above which an adverse biological effect always occurs for a particular data set. Barrick et al. (1988) list specific AET values for several different species or biological indicators. For the purposes of this assessment, EPA defined the AET-low as the lowest AET among applicable biological indicators, and the AET-high as the highest AET among applicable biological indicators. By the nature of how the AET is derived, less stringent values might evolve as more data sets become available.

For the NSI data evaluation, the upper screening values were considered to be the ERM, PEL, draft SQC (when using default TOC value of 1 percent), SQAL, and AET-high for a given chemical. The lower screening values were considered to be the ERL, TEL, draft SQC (when using default TOC of 1 percent), SQAL, and AET-low for a given chemical. Because they are not based on ranges of effects, the single freshwater aquatic life draft SQC and SQAL values for a given chemical served as both the high and low screening values.

For a sampling station to be classified as Tier 1, a chemical measurement must have exceeded at least two of the upper screening values. If a sediment chemistry measurement exceeded any one of the lower screening values, the sampling station was classified as Tier 2. If sediment concentrations at a sampling station did not exceed any screening values or there were no data for chemicals that have assigned screening values, the sampling station was categorized as Tier 3 unless otherwise categorized by another parameter.

Under this approach, a sampling station could be classified as Tier 1 from elevated concentrations of cadmium, copper, lead, nickel, or zinc based only on a comparison of [SEM] to [AVS]; that is, sampling stations could not be classified as Tier 1 based on an exceedance of two upper screening values for any of the five metals. However, sampling stations were classified as Tier 2 for these five metals based on an exceedance of one of the lower screening values if AVS data were not available.

Sediment Chemistry TBPs Exceed Screening Criteria [4, 7]

This evaluation parameter addresses the risk to human consumers of organisms exposed to sediment contaminants. The theoretical bioaccumulation potential (TBP) is an estimate of the equilibrium concentration (concentration that does not change with time) of a contaminant in tissues if the sediment in question were the only source of contamination to the organism. At present, the TBP calculation can be performed only for nonpolar organic chemicals. The TBP is estimated from the concentration of contaminant in the sediment, the organic carbon content of the sediment, the lipid content of the organism, and the relative affinity of the chemical for sediment organic carbon and animal lipid content. This relative affinity is measured in the field and is called a biota-sediment accumulation factor (BSAF, as discussed in detail in Appendix C). In practice, field measured BSAFs can vary by an order of magnitude or greater for individual compounds depending on location and time of measurement. For this evaluation, EPA selected BSAFs that represents the central tendency, suggesting an approximate 50 percent chance that an associated tissue residue level would exceed a screening risk value.

In the evaluation of NSI data, if a calculated sediment chemistry TBP value exceeded a screening value derived using standard EPA risk assessment methodology or the Food and Drug Administration (FDA) tolerance/action or guidance level, and if a corresponding tissue residue level for the same chemical for a resident species at the same sampling station also exceeded one of those screening values, the station was classified as Tier 1. Individual chemical risk levels were considered separately; that is, risks from multiple contaminants were not added. Both sediment chemistry and tissue residue samples must have been taken from the same sampling station. If tissue residue levels for the same chemical for a resident species at the same sampling station did not exceed EPA risk levels or FDA levels or there were no corresponding tissue data, the sampling station was classified as Tier 2. If neither TBP values nor fish tissue residue levels exceeded EPA risk levels or FDA levels, or if no chemicals with TBP values, EPA risk levels, or FDA levels were measured, the sampling station was classified as Tier 3 unless otherwise classified by another parameter. A detailed description of the methods used to develop TBP values and to determine the EPA risk levels used in this comparison is presented in Appendix B.

Tissue Residue Data [8, 9, 10]

Tissue residue data were used to assess potential adverse effects on humans from the consumption of fish that become contaminated through exposure to contaminated sediment. Only those species considered benthic, non-migratory (resident), and edible by human populations were included in human health assessments. A list of species included in the NSI and their characteristics is presented in Appendix F.

Sampling stations at which human health screening values for dioxin and PCBs were exceeded in fish tissues were classified as Tier 1. For these chemicals, corroborating sediment chemistry data were not required. If human health screening values for dioxin or PCBs in fish tissue were not exceeded or if neither chemical was measured, the sampling station was classified as Tier 3 unless otherwise classified by another parameter.

For other chemicals, both a tissue residue level exceeding an FDA tolerance/action or guidance level or EPA risk level and a sediment chemistry TBP value exceeding that level for the same chemical were required to classify a sampling station as Tier 1. If tissue residue levels exceeded FDA levels or EPA risk levels but corresponding TBP values were not exceeded at the same station (or there were no sediment chemistry data from that station), the sampling station was classified as Tier 2. If neither fish tissue levels nor TBP values exceeded EPA risk levels or FDA levels, or if no chemicals with TBP values, EPA risk levels, or FDA levels were measured, the sampling station was classified as Tier 3 unless otherwise classified by another parameter.

Toxicity Data [11, 12]

Toxicity data were used to classify sediment sampling stations based on their demonstrated lethality to aquatic life in laboratory bioassays. Nonmicrobial sediment toxicity tests with a mortality endpoint were evaluated. Toxicity test results that lacked control data, or had control data that indicated greater than 20 percent mortality (less than 80 percent survival), were excluded from further consideration. The EPA has standardized testing protocols for marine and freshwater toxicity tests. A review of several protocols for sediment toxicity tests suggests that mortality in controls may range from 10 to 30 percent, depending on the species, to be considered an acceptable test result (API, 1994). Current amphipod test requirements indicate that controls should have less than 10 percent mortality (API, 1994; USEPA, 1994b).

For the NSI data evaluation, EPA considered significant toxicity as a 20 percent difference in survival from control survival. For example, significant toxicity occurred if control survival was 80 percent and experimental survival was 60 percent or less.

For this evaluation parameter, corroboration of multiple tests was considered more indicative of probable associated adverse effects than the magnitude of the effect in a single test. Lethality demonstrated by two or more single-species tests using two different test species (at least one of which had to be a solid-phase test) placed a sampling station in Tier 1. A sampling station was classified as Tier 2 if toxicity was demonstrated by one single-species nonmicrobial toxicity test. If lethality was not demonstrated by a nonmicrobial toxicity test, or if toxicity test data were not available, the sampling station was classified as Tier 3 unless otherwise classified by another parameter.

Incorporation of Regional Comments on the Preliminary Evaluation of Sediment Chemistry Data

Several reviewers from different EPA Regions and states provided comments on the May 16, 1994, preliminary evaluation of sediment chemistry data. The comments included more than 150 specific comments identifying additional locations with contaminated sediment that had not been identified in the preliminary evaluation. Since the preliminary evaluation, the final NSI methodology has been developed and implemented. The updated methodology has been refined significantly to include tissue residue and toxicity data as well as revised screening values. Data corresponding to any additional comments that required further review were divided into two categories: (1) data that incorrectly identified contaminated sediment and (2) additional water bodies that contain areas of sediment contamination. The first category primarily addressed sampling stations identified in the preliminary assessment as exceeding sediment chemistry screening values for specific contaminants that reviewers stated were located in water bodies that are not contaminated from the chemical(s) in question.

EPA examined all NSI sampling stations that had been identified in the preliminary evaluation as exceeding a sediment quality screening value, but were located in water bodies that reviewers of the preliminary evaluation identified as not being contaminated by that specific contaminant or contaminants. If the sampling station in question was classified in this final evaluation as Tier 1 based only on the specific contaminant(s) identified by the reviewer as not being a problem, the sampling station was removed from the Tier 1 category and placed in the Tier 3 category. Only a few sampling stations were moved from the Tier 1 category to the Tier 3 category as a result of this procedure. Stations identified in the NSI evaluation as Tier 1 based on other chemicals not identified by the reviewer or because of toxicity data were not removed from Tier 1.

Additional water bodies that reviewers identified as potential areas of significant contamination were evaluated to determine whether sampling stations along those water bodies were classified as Tier 1 based on the final NSI data evaluation. Locations or water bodies identified by reviewers as potential areas of significant contamination are discussed separately in the results (Chapter 3).

Evaluation Using EPA Wildlife Criteria

In addition to the evaluation parameters described above and presented in Table 2-2, EPA conducted an assessment of NSI data based on a comparison of sediment chemistry TBP values and fish tissue values to EPA wildlife criteria developed for the Great Lakes. This evaluation, however, was not included with the results of evaluating the NSI data based on the other parameters. The results of evaluating NSI data based on wildlife criteria are presented in a separate section of Chapter 3. Wildlife criteria based solely on fish tissue concentrations were derived for EPA wildlife criteria for water that are presented in the *Great Lakes Water Quality Initiative Criteria Documents for the Protection of Wildlife* (USEPA, 1995a). EPA has developed wildlife criteria for four contaminants: DDT, mercury, 2,3,7,8-TCDD, and PCBs. The method to adjust these wildlife criteria for the NSI data evaluation is explained in detail in Appendix B.

Chapter 3

Findings

This chapter presents the results of the evaluation of NSI data based on the methodology described in Chapter 2. This discussion includes a summary of the results of national, regional, and state assessments.

National Assessment

EPA evaluated a total of 21,096 sampling stations nationwide as part of the NSI data evaluation (Figure 3-1). Of the sampling stations evaluated, 5,521 stations (26 percent) were classified as Tier 1, 10,401 (49 percent) were classified as Tier 2, and 5,174 (25 percent) were classified as Tier 3 (Table 3-1). This distribution suggests that state monitoring programs (accounting for the majority of NSI data) have been efficient and successful in focusing their sampling efforts on areas where contamination is known or suspected to occur. The frequency of Tier 1 classification based on the evaluation of all NSI data is greater than from data sets derived from purely random sampling.

The national distribution of Tier 1 sampling stations is illustrated in Figure 3-2. The distribution of Tier 1 stations depicted in Figure 3-2 must be viewed in the context of the distribution of all sampling stations depicted in Figure 3-1. Table 3-1 presents the number of sampling stations in each tier by EPA Region. The greater number of Tier 1 and Tier 2 sampling stations in some Regions is to some degree a function of a larger set of available data. Although there are 17 times more Tier 1 stations in EPA Region 4 (southeastern states) than in EPA Region 8 (mountain states), there are also 13 times more Tier 3 stations.

The NSI sampling stations were located in 6,744 individual river reaches throughout the contiguous United States (based on EPA's River Reach File 1; Bondelid and Hanson, 1990). A river reach can be part of a coastal shoreline, a lake, or a length of stream between two major tributaries ranging from approximately 1 to 10 miles long. NSI sampling stations were located in approximately 11 percent of all river reaches identified in the contiguous United States (Table 3-1 and Figure 3-3). Four percent of all river reaches in the United States contained at least one sampling station classified as Tier 1.

Five percent of all reaches contained at least one sampling station classified as Tier 2 (but none as Tier 1). In 2 percent of reaches in the contiguous United States, all of the sampling stations were classified as Tier 3. EPA has not yet catalogued river reaches outside the contiguous United States (e.g., Alaska, Hawaii, Puerto Rico), and some sampling stations in the ocean were not linked to a specific reach. Sampling bias toward areas of known or suspected contamination may be more pronounced in some Regions compared to others, and may be related to the relative extent of sampling. The results presented on Table 3-1 appear to indicate that the smaller the percentage of reaches with available data, the greater the likelihood those reaches will contain a Tier 1 or Tier 2 sampling station.

Not all sampling programs target only sites of known or suspected contamination. The NSI includes data from the National Oceanic and Atmospheric Administration's (NOAA's) National Status and Trends Program, which is part of the COSED database, and EPA's Environmental Monitoring and Assessment Program (EMAP). These are examples of sampling programs in which most sampling stations are not targeted at locations of known or suspected contamination. Based on these data alone, the percentage of sampling stations placed in each tier differs considerably from the percentage of sampling stations in each tier based on an evaluation of all the data in the NSI. Smaller percentages of COSED and EMAP sampling stations are categorized as Tier 1 (18 percent for COSED and 14 percent for EMAP compared to 26 percent for all NSI sampling stations), greater percentages are categorized as Tier 2 (75 percent for COSED and 68 percent for EMAP compared to 49 percent for all NSI stations), and smaller percentages are categorized as Tier 3 (7 percent for COSED and 18 percent for EMAP compared to 25 percent for all NSI sampling stations). This may reflect the lower detection limits of more sensitive analytical chemistry techniques, the sensitivity of Tier 2 evaluation parameters, and the nearly ubiquitous presence of lower to intermediate levels of contamination in areas sampled by these programs.

The NSI contains over 1.5 million individual records of contaminant measurements in sediment and fish

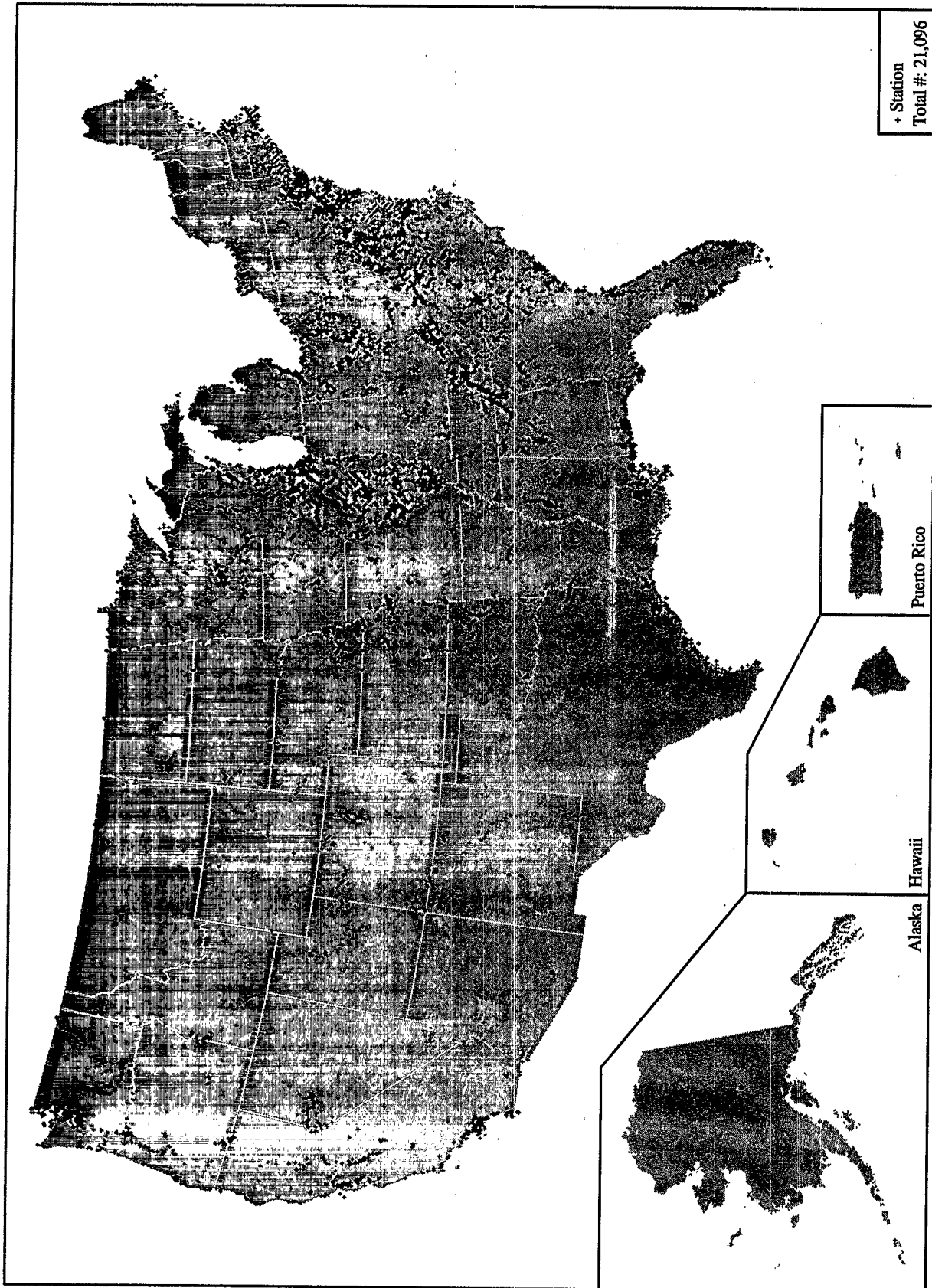

Figure 3-1. Location of All NSI Sampling Stations.

Table 3-1. National Assessment: Evaluation Results for Sampling Stations and River Reaches by EPA Region

EPA Region (State)	Station Evaluation						River Reach Evaluation ^a							
	Tier 1		Tier 2		Tier 3		Number of Stations Not Identified by an RFI Reach ^c	Reaches w/at Least 1 Station in Tier 1	Reaches w/at Least 1 Station in Tier 2 ^d	Reaches w/all Stations in Tier 3	Total # Reaches w/at Least 1 Station Evaluated	Total Reaches in Region	% of all Reaches in Region w/at Least 1 Station Evaluated	% of Reaches w/at Least 1 Tier 1 or Tier 2 Station
	#	% ^b	#	% ^b	#	% ^b								
Region 1 (CT, ME, MA, NH, RI, VT)	298	27	646	59	158	14	361	59	65	7	131	2,648	5	5
Region 2 (NY, NJ, PR)	355	32	559	51	182	17	173	116	147	29	292	1,753	17	15
Region 3 (DE, DC, MD, PA, VA, WV)	318	17	934	49	658	34	92	209	453	226	888	3,247	27	20
Region 4 (AL, FL, GA, KY, MS, NC, SC, TN)	1,157	23	1,930	39	1,872	38	343	566	684	520	1,770	9,749	18	13
Region 5 (IL, IN, MI, MN, OH, WI)	1,418	33	2,137	50	735	17	108	594	570	268	1,432	6,025	24	19
Region 6 (AR, LA, NM, OK, TX)	382	24	837	52	397	24	124	266	341	192	799	7,293	11	8
Region 7 (IA, KS, MO, NE)	330	33	393	39	288	28	N/A	246	182	88	516	4,857	11	9
Region 8 (CO, MT, ND, SD, UT, WY)	68	13	327	61	140	26	N/A	61	153	91	305	13,492	2	2
Region 9 (AZ, CA, HI, NV)	468	28	942	55	289	17	794	119	92	43	254	4,601	6	5
Region 10 (AK, ID, OR, WA)	727	25	1,696	59	455	16	497	147	174	72	393	10,178	4	3
Total for U.S. ^e	5,521	26	10,401	49	5,174	25	2,492	2,371	2,843	1,530	6,744	62,742	11	8

^aRiver reaches based on EPA River Reach File 1 (RFI).^bPercent of all stations evaluated in the NSI in the Region.^cStations not identified by an RFI reach were located in coastal or open water areas.^dNo stations in these reaches were included in Tier 1.^eBecause some reaches occur in more than one Region, the total number of reaches in each category for the country might not equal the sum of reaches in the Regions.

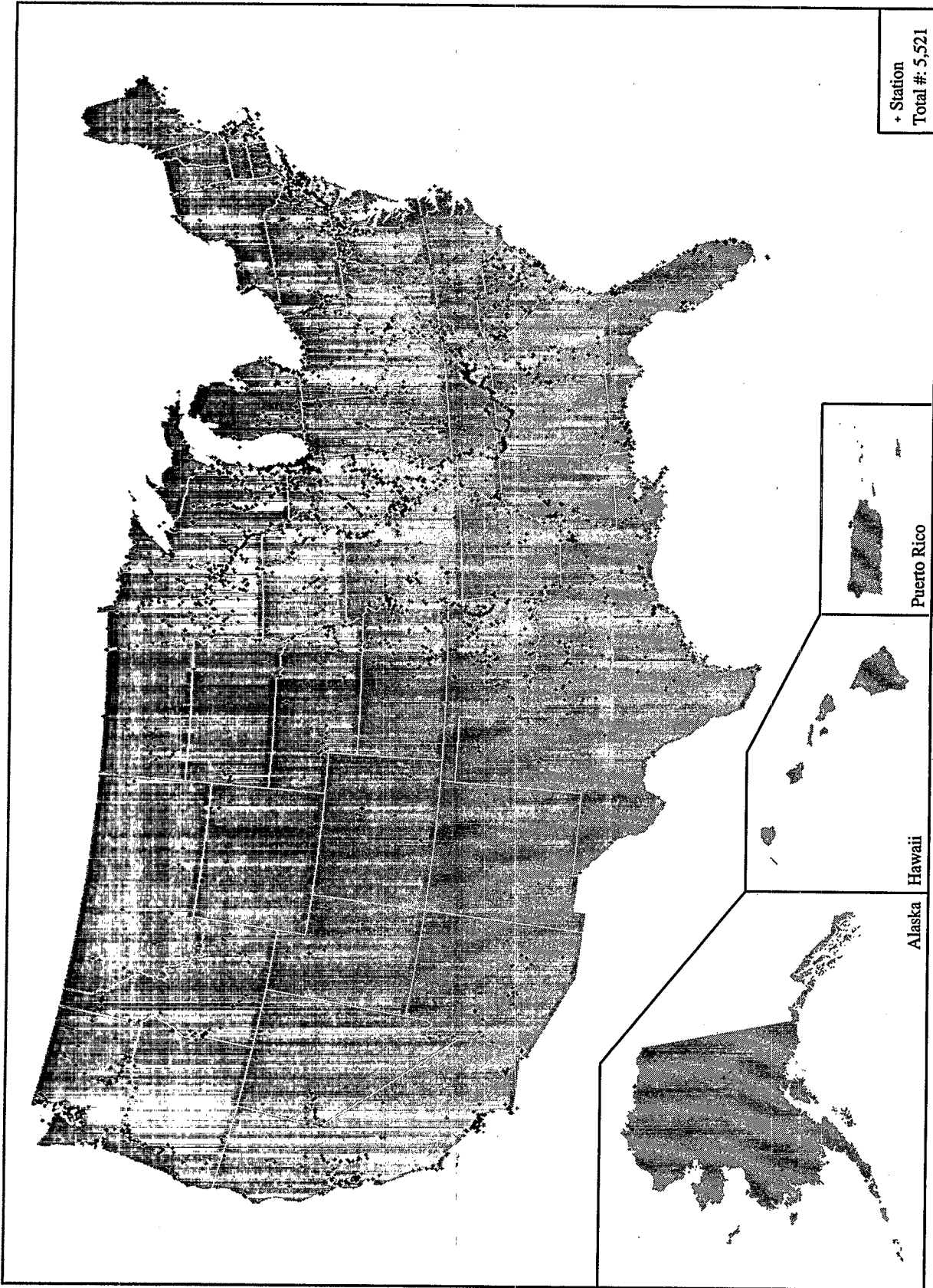

Figure 3-2. Sampling Stations Classified as Tier 1 (Associated Adverse Effects are Probable).

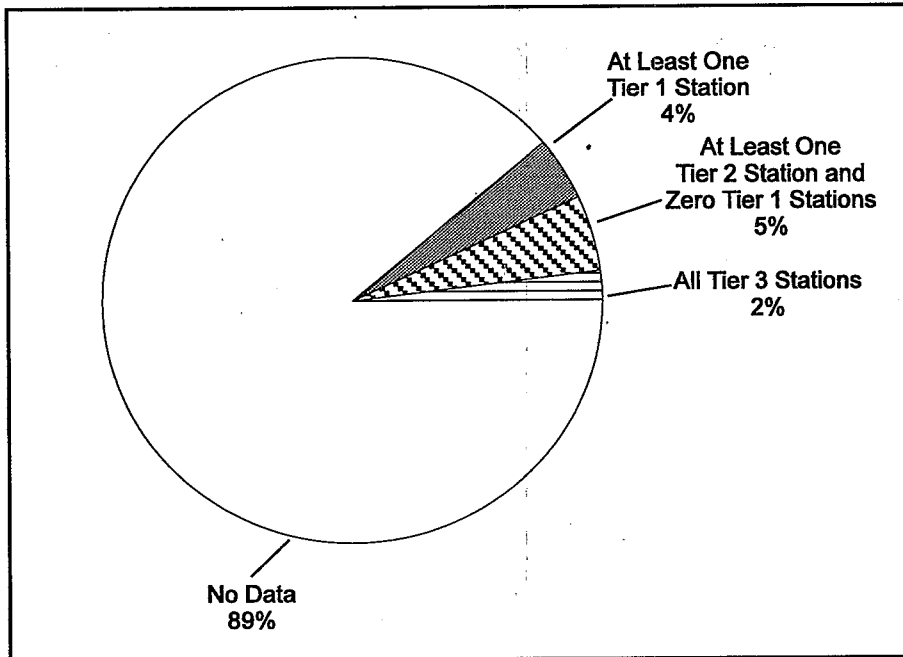

Figure 3-3. National Assessment: Percent of River Reaches That Include Tier 1, Tier 2, and Tier 3 Sampling Stations.

tissue (Figure 3-4). Slightly more than one-third of these measurements represent concentrations recorded as above a detection limit. Using available assessment parameters, EPA could evaluate nearly two-thirds (approximately 380,000) of these measurements for the probability of association with adverse effects. Approximately one-quarter of the measurements above detection (nearly 40 percent of measurements that could be evaluated) reflect either a Tier 1 or Tier 2 level of contamination. Figure 3-4 also shows the distribution of measurements at the Tier 1 and Tier 2 level of contamination by chemical class. Chemicals that have been measured over the past 15 years, can be evaluated using the NSI evaluation approach, and accumulate to levels associated with an increased probability of adverse effects are predominantly persistent, hydrophobic organic compounds and metals.

Data related to more than 230 different chemicals or chemical groups were included in the NSI evaluation. Approximately 40 percent of these chemicals or chemical groups (97) were present at levels that resulted in classification of sampling stations as Tier 1 or Tier 2. Table 3-2 presents the chemicals or chemical groups that resulted in classification of more than 1,000 Tier 1 or Tier 2 sampling stations. Sampling stations are reported more than once in Table 3-2 because it is common for a station to have elevated concentration levels for multiple chemicals.

The contaminants most frequently at levels in fish or sediment where associated adverse effects are prob-

able include PCBs (58 percent of the 5,521 Tier 1 sampling stations) and mercury (20 percent of Tier 1 sampling stations). Pesticides, most notably DDT and metabolites at 15 percent of Tier 1 sampling stations, and polynuclear aromatic hydrocarbons (PAHs), such as pyrene at 8 percent of Tier 1 sampling stations, also were frequently at levels where associated adverse effects are probable.

Dry weight measures of divalent metals other than mercury (e.g., copper, cadmium, lead, nickel, and zinc) were not used to place a sampling station in Tier 1 without an associated measurement of acid volatile sulfide, a primary mediator of bioavailability not often available in the data base. The [SEM]-[AVS]

methodology for sediment assessment is relatively new, and AVS measurements have not commonly been made during sediment analyses. As a result, metals other than mercury (which also include arsenic, chromium, and silver) are solely responsible for only 6 percent of Tier 1 sampling stations and overlap with mercury or organic compounds at an additional 6 percent of Tier 1 sampling stations. In contrast, metals other than mercury are solely responsible for about 28 percent of the 15,992 Tier 1 and Tier 2 sampling stations, and overlap with mercury or organic compounds at an additional 28 percent of Tier 1 and Tier 2 sampling stations. The remaining 44 percent of Tier 1 and Tier 2 sampling stations are classified solely for mercury or organic compounds.

Two important issues in interpreting the results of sampling station classification are naturally occurring "background" levels of chemicals and the effect of chemical mixtures. Site-specific naturally occurring (or background) levels of chemicals may be an important risk management consideration in examining sampling station classification. This is most often an issue for naturally occurring chemicals such as metals and PAHs. In addition, although the sediment chemistry screening levels for individual chemicals are used as indicators of potential adverse biological effects, other co-occurring chemicals (which may or may not be measured) can cause or contribute to any observed adverse effect at specific locations.

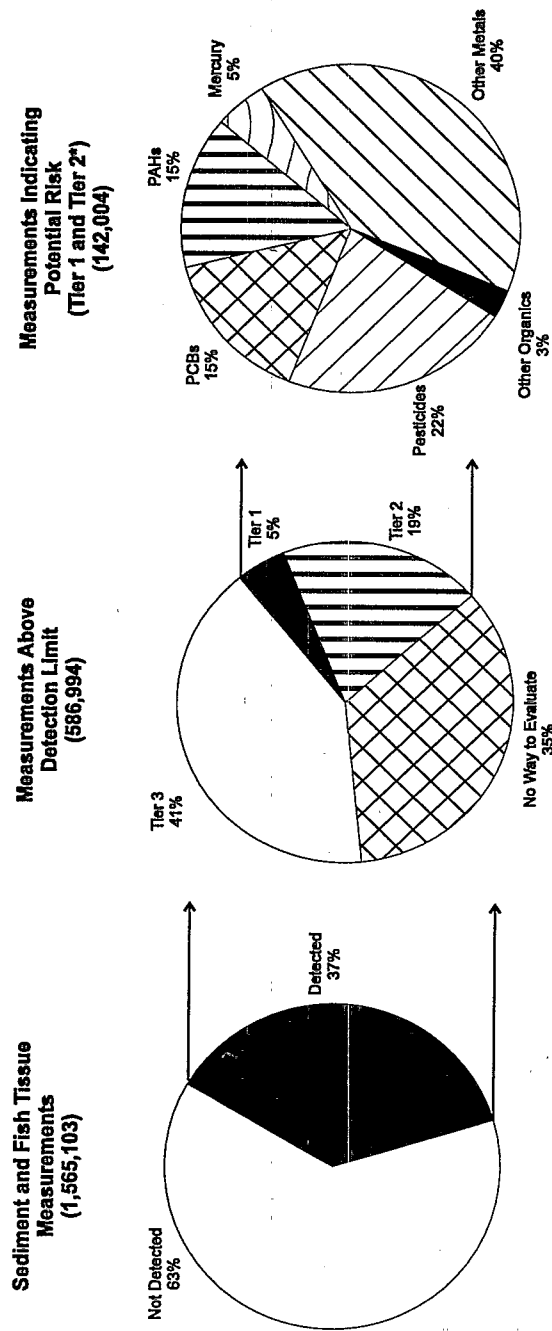

*For Tier 1 alone: 27,358 measurements indicate potential risk, distributed among PCBs (62 percent) PAH (13 percent), pesticides (9 percent) mercury (7 percent), other organics (5 percent), and other metals (4 percent)

Figure 3-4. National Assessment: Percent of NSI Measurements That Indicate Potential Risk.

Table 3-2. Chemicals or Chemical Groups Most Often Associated With Tier 1 and Tier 2 Sampling Station Classifications

Chemical or Chemical Group	Number of Stations									
	Total # of Stations Evaluated	Based on All Measurement Parameters					Based on Aquatic Life Parameters		Based on Human Health Parameters	
		Combined Tiers 1 & 2	Percent of All Tier 1 and Tier 2 Stations	Tier 1	Percent of All Tier 1 Stations	Tier 2	Tier 1	Tier 2	Tier 1	Tier 2
Copper	16,161	7,172	45	-	-	7,172	-	7,167	-	5
Nickel	12,447	6,284	39	-	-	6,284	-	6,284	-	-
Lead	16,791	5,681	36	-	-	5,681	-	5,415	-	328
Polychlorinated biphenyls	12,276	5,454	34	3,175	58	2,279	963	1,219	2,256	3,198
Arsenic	13,200	5,392	34	182	3	5,210	182	4,658	-	605
Cadmium	16,010	4,808	30	-	-	4,808	-	4,773	-	41
Mercury	15,649	4,333	27	1,122	20	3,211	1,122	3,127	-	103
Zinc	15,160	3,468	22	-	-	3,468	-	3,451	-	17
DDT (and metabolites)	11,462	3,422	21	803	15	2,619	798	2,203	21	1,402
Chromium	15,222	3,070	19	278	5	2,792	278	2,786	-	7
Dieldrin	10,284	2,597	16	58	1	2,539	49	1,006	9	2,456
Chlordane	10,697	2,169	14	11	<1	2,158	-	1,303	11	1,697
Benzo(a)pyrene	5,435	1,993	13	287	5	1,706	287	1,051	-	1,990
Pyrene	5,798	1,920	12	431	8	1,489	431	1,489	-	10
Chrysene	5,300	1,427	9	166	3	1,261	166	1,261	-	30
Dibenzo(a,h)anthracene	4,896	1,383	9	337	6	1,046	337	1,018	-	1,092
Benzo(a)anthracene	5,120	1,366	9	214	4	1,152	214	1,106	-	847
Bis(2-ethylhexyl)phthalate	3,559	1,190	7	347	6	843	347	823	-	406
Naphthalene	5,246	1,186	7	254	5	932	254	932	-	5
Fluoranthene	5,814	1,114	7	210	4	904	210	904	-	11
Fluorene	5,175	1,107	7	201	4	906	201	906	-	5
Silver	8,022	1,096	7	302	5	794	302	794	-	-
Total for all chemicals in the NSI database	21,096	15,922	-	5,521	-	10,401	3,287	9,921	2,327	6,196

The total number of sampling stations classified as Tier 1 or Tier 2 for a given chemical as presented in Table 3-2 may not be representative of the potential risk posed by that chemical. Although there may be few overall observations for some chemicals, the frequency of detection in sediment and tissue and the frequency with which those chemicals result in Tier 1 or Tier 2 risk may be high. (See Appendix D, Table D-2.)

The results of the analysis for three chemicals (arsenic, silver, and phthalate esters) might be misleading. Arsenic is typically analyzed in biota as "total arsenic", which includes all forms of arsenic. The EPA risk level for comparison with measured values was derived for the highly toxic effects of inorganic arsenic. However, arsenic in the edible portions of fish and shellfish is predominantly found in a nontoxic organic form (USEPA, 1995c). For this analysis, a precautionary

approach was taken to account for the human health risk from the small amount of inorganic arsenic included in total arsenic measures and for measures that, in fact, represent only inorganic arsenic. Silver, like copper, cadmium, lead, nickel, and zinc, binds to sulfide in sediment. However, silver cannot be evaluated like these other metals in the [SEM]-[AVS] assessment for a number of reasons, including that one molecule of sulfide binds two molecules of silver rather than just one as is the case for the other metals. Recent research suggests that if any AVS is measured, silver will not be bioavailable or toxic to exposed aquatic organisms (Berry et al., 1996). In the NSI data evaluation, silver is not evaluated on the basis of AVS measurement, and exceedance of two upper thresholds for aquatic life protection can classify a sampling station as Tier 1. In the case of phthalate esters, high concentrations in samples might be an indication of contamination during sample handling and not necessarily an indication of sediment contamination at the sampling station.

Table 3-2 also separately identifies the number of sampling stations categorized as Tier 1 or Tier 2 for aquatic life effects and for human health effects. Evaluation parameters indicative of aquatic life effects include:

- Comparison of sediment chemistry measurements to EPA draft sediment quality criteria (SQCs).
- Comparison of sediment chemistry measurements to other screening values (SQCs when percent organic carbon is not reported, SQALs, ERL/ERMs, PEL/TELS, and AETs).
- Comparison of [SEM] to [AVS].
- Results of toxicity tests.

Human health evaluation parameters included:

- Comparison of sediment chemistry TBP to EPA risk levels or FDA tolerance/action or guideline levels.
- Comparison of fish tissue levels of PCBs and dioxin to EPA risk levels. (A sampling station can be classified as Tier 1 without corroborating sediment chemistry data.)
- Comparison of fish tissue levels to EPA risk levels and FDA tolerance/action or guideline levels.

The evaluation results indicate that sediment contamination associated with probable or possible but infrequent adverse effects exists for both aquatic life and human health. More sampling stations were classified as either

Tier 1 or Tier 2 for aquatic life concerns than for human health concerns. About 41 percent more sampling stations were classified as Tier 1 for aquatic life (3,287 stations) than for human health (2,327 stations). About 60 percent more sampling stations were classified as Tier 2 for aquatic life (9,921 stations) than were classified as Tier 2 for human health (6,196 stations). The locations of sampling stations classified as Tier 1 or Tier 2 for aquatic life concerns are illustrated in Figure 3-5, and the locations of those classified as Tier 1 or Tier 2 for human health concerns are illustrated in Figure 3-6.

EPA analyzed the results to determine which evaluation parameters most often caused sampling stations to be classified as either Tier 1 or Tier 2 (see Table 3-3). Most of the sampling stations classified as Tier 1 (3,283 stations) or Tier 2 (9,882 stations) were placed in those categories because measured sediment contaminant levels exceeded screening values. The comparison of fish tissue levels of PCBs and dioxins to EPA risk levels triggered placement of the second highest number of sampling stations in Tier 1 (2,313 stations). The comparison of sediment chemistry TBP values to FDA levels and EPA risk levels triggered placement of the second highest number of sampling stations in Tier 2 (5,671 stations). The AVS and toxicity parameters triggered placement of the fewest sampling stations in Tier 1 (8 stations each) and Tier 2 (146 stations for AVS and 183 stations for toxicity). These results reflect both data availability and evaluation parameter sensitivity.

The lack of data required to apply some important assessment parameters hampered EPA's efforts to determine the incidence and severity of sediment contamination. For example, a Tier 1 classification based on divalent metal concentrations in sediment required an associated acid-volatile sulfide (AVS) measurement. Also, a Tier 1 classification for potential human health effects required both sediment chemistry and fish tissue residue data for all chemicals except PCBs and dioxins. These data combinations frequently were not available. Table A-2 in Appendix A presents the total number of NSI stations where sediment chemistry data, related biological data, and matched data (i.e., sediment chemistry and biological data taken at the same sampling station) were collected. AVS measurements were available at only 1 percent of the evaluated stations. Likewise, matched sediment chemistry and fish tissue data were available at only 8 percent of the evaluated stations. Toxicity data were also limited: bioassay results were available at only 6 percent of the evaluated stations.

To help judge the effectiveness of the NSI data evaluation approach, EPA examined the agreement between

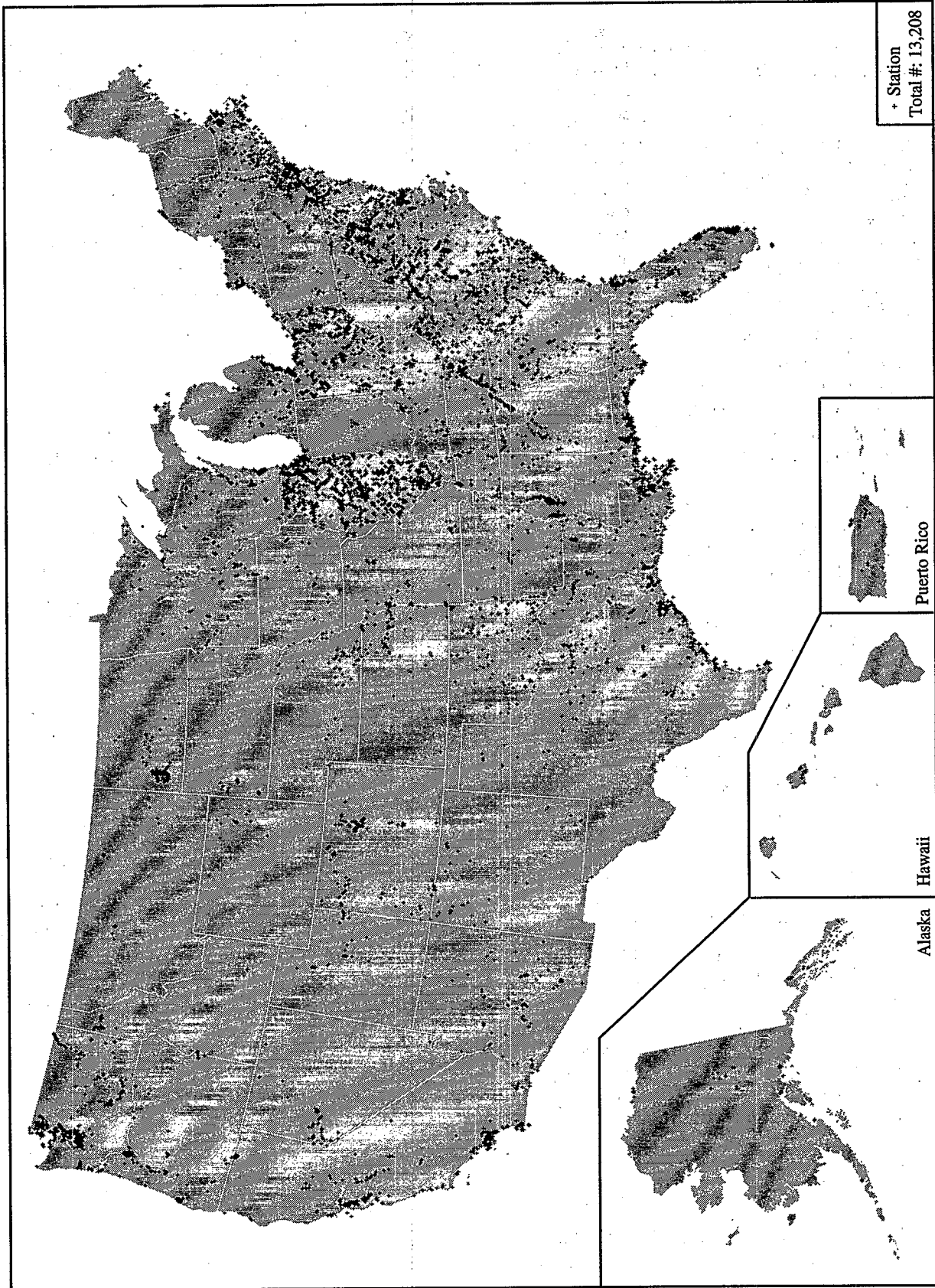

Figure 3-5. Sampling Stations Classified as Tier 1 or Tier 2 for Potential Risk to Aquatic Life.

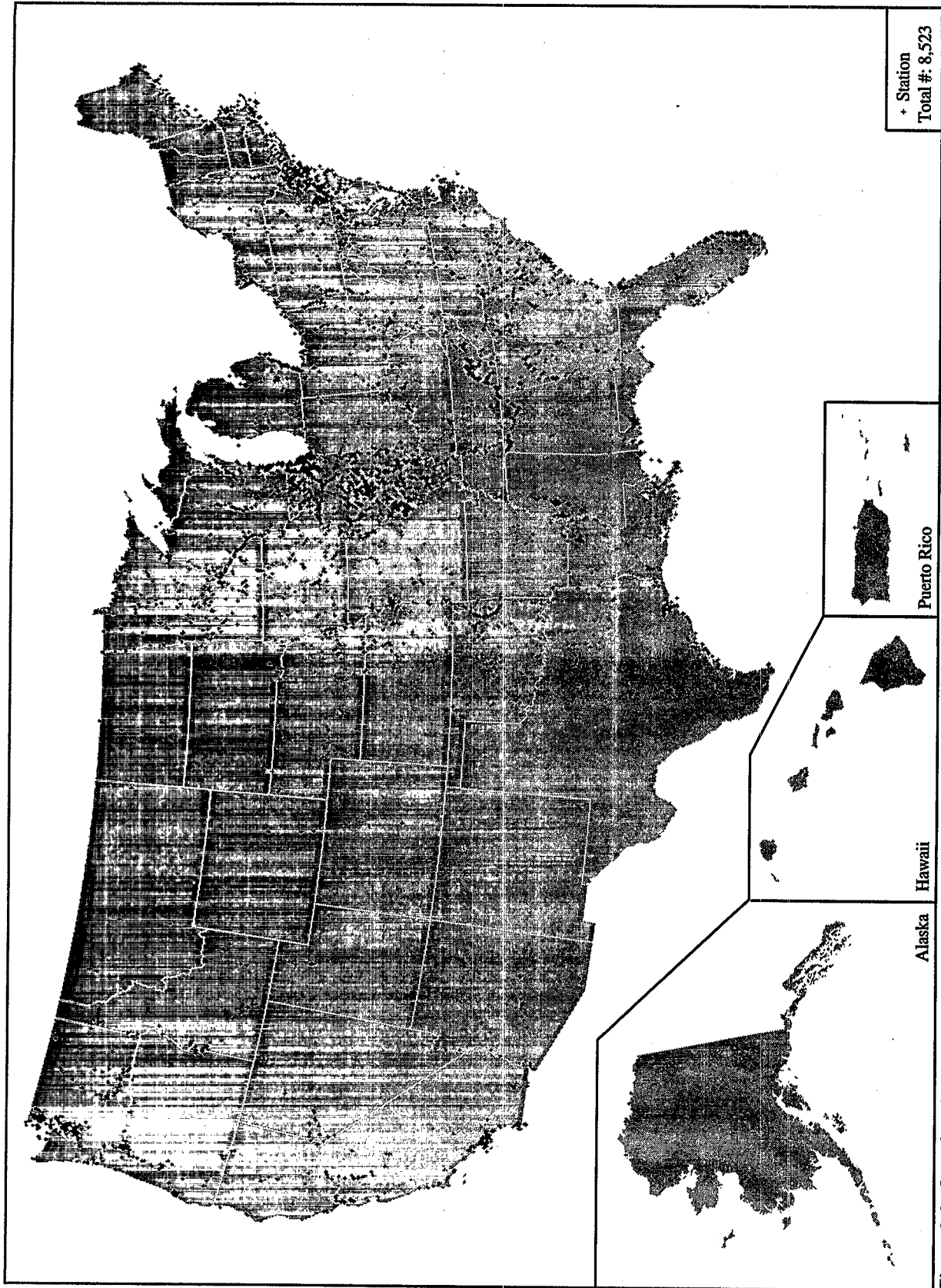

Figure 3-6. Sampling Stations Classified as Tier 1 or Tier 2 for Potential Risk to Human Health.

Table 3-3. Number of Sampling Stations Classified as Tier 1 and Tier 2 Based on Each Component of the Evaluation Approach (see Table 2-2)

Measurement Parameter	Number of Sampling Stations in Tier 1	Number of Sampling Stations in Tier 2
Sediment chemistry values exceed draft sediment quality criteria	97	NA
[SEM]-[AVS] comparison	8	146
Sediment chemistry values exceed threshold values	3,283	9,882
Sediment chemistry TBP and fish tissue levels exceed risk levels or action levels	126	NA
Sediment chemistry TBP exceeds risk levels or action levels	NA	5,671
Fish tissue levels exceed risk levels or action levels	NA	2,789
Tissue levels of PCBs or dioxins exceed risk levels	2,313	NA
Toxicity test results	8	183

matched sediment chemistry and toxicity test results for the 805 NSI sampling stations where both data types were available and could be evaluated. The toxicity test data indicate whether significant lethality to indicator organisms occurs as a result of exposure to sediment. Tier 1 classifications for aquatic life effects from sediment chemistry data correctly matched toxicity test results for about three-quarters of the sampling stations, with the remainder balanced between false positives (12 percent) and false negatives (14 percent). In contrast, when Tier 2 classifications from sediment chemistry data are added in, false negatives drop to less than 1 percent at the expense of false positives (which increase to 68 percent) and correctly matched sampling stations (which drop to 30 percent). This result highlights the fact that classification in Tier 2 is very conservative, and it does not indicate a high probability of adverse effects to aquatic life. If bioassay test results for sublethal (chronic) endpoints such as reproductive effects were included in the NSI evaluation, the rate of false positives would likely decrease and correctly matched sampling stations would likely increase for both tiers.

EPA also conducted a separate analysis of the correlation of toxicity data and exceedances of SQCs and SQALs (exclusive of other threshold values). From the results of this study, there are 2,037 observations of a SQC or SQAL exceedance at 916 sampling stations. These 916 sampling stations are located in 405 distinct RF1 reaches, which are in turn located in 218 distinct watersheds. Matching toxicity test data are available at

39 of these 916 sampling stations. Toxicity test results indicate that one or more SQC or SQAL exceedances are associated with significant lethality (acute effects) to indicator organisms slightly more than half of the time (22 of 39 sampling stations). SQCs and SQALs are levels set to be protective of acute and chronic effects, such as effects on reproduction or growth, for 95 percent of benthic species. The NSI currently does not contain matching chronic toxicity test data to compare with sediment chemistry measures.

For a number of reasons, known contaminated sediment locations in the United States might not have been classified as Tier 1 or Tier 2 based on the evaluation of NSI data. The NSI does not presently include data describing every sampled location in the Nation. Therefore, numerous sampling stations were not evaluated for this first report to Congress. However, additional databases will be added to the NSI and more sampling stations will be evaluated for future reports to Congress.

During an initial screening of the NSI data, EPA noted data quality problems that might have affected all or many of the data reported in a given database (e.g., the Virginia State Water Control Board organic chemical data reported in STORET). Databases with obvious quality problems were not included in the NSI data evaluation. Also, if a database included in the NSI did not have associated locational information (latitude/longitude), data in that database were not included in the NSI data evaluation (e.g., EPA's Great

Lakes Sediment Quality Database). To reduce the chances of overlooking sampling locations that have obvious sediment contamination problems, EPA sent a preliminary evaluation of sediment chemistry data to each EPA Region so knowledgeable staff would have an opportunity to list additional contaminated sediment locations not identified in the NSI evaluation. These locations are presented at the end of this chapter. Despite such efforts, some sediment sampling locations known to have contamination problems still have not been listed in this first report to Congress.

Watershed Analysis

The potential risk of adverse effects to aquatic life and human health is greatest in areas with a multitude of contaminated locations. The assessment of individual sampling stations is useful for estimating the number and distribution of contaminated spots and the overall magnitude of sediment contamination in monitored waterbodies of the United States. However, a single "hot spot" might not pose a great threat to either the benthic community at large or consumers of resident fish because the spatial extent of exposure could be small. On the other hand, if many contaminated spots are located in close proximity, the spatial extent and probability of exposure are much greater. EPA examined sampling station classifications within watersheds to identify areas of probable concern for sediment contamination (APCs), where the exposure of benthic organisms and resident fish to contaminated sediment may be more frequent. In this report, EPA defines watersheds by 8-digit United States Geological Survey (USGS) hydrologic unit codes (the cataloging unit), which are roughly the size of a county.

Watersheds containing APCs are those that include at least 10 Tier 1 sampling stations, and in which at least 75 percent of all sampling stations were classified as either Tier 1 or Tier 2. These dual criteria are based on empirical observation of the data. NSI Sampling stations are located within 1,367 watersheds, or approximately 65 percent of the total number of watersheds in the continental United States. To identify APCs, EPA first examined the frequency distribution of the number of Tier 1 sampling stations within these watersheds. The upper 10 percent of watersheds with sampling stations had 10 or more sampling stations classified as Tier 1. Because approximately three-quarters of all sampling stations in the nation are classified as Tier 1 or Tier 2, EPA determined that APCs should also reflect at least this distribution. This second requirement slightly reduced the number watersheds containing APCs.

The definition of "area of probable concern" was developed for this report to identify watersheds for which further study of the effects and sources of sediment contamination, and possible risk reduction needs, would be warranted. Where data have been generated through intensive sampling in areas of known or suspected contamination within a watershed, the APC definition should identify watersheds which contain even relatively small areas that are considerably contaminated. However, this designation does not imply that sediment throughout the entire watershed, which is typically very large compared to the extent of available sampling data, is contaminated. On the other hand, where data have been generated through comprehensive sampling, or where sampling stations were selected randomly or evenly distributed throughout a sampling grid, the APC definition might not identify watersheds that contain small or sporadically contaminated areas. A comprehensively surveyed watershed of the size typically delineated by a USGS cataloging unit might contain small but significant areas that are considerably contaminated, but might be too large in total area for 75 percent of all sampling stations to be classified as Tier 1 or Tier 2. Limited random or evenly distributed sampling within such a watershed also might not yield 10 Tier 1 sampling stations. Thus, the process used to identify watersheds containing APCs may both include some watersheds with limited areas of contamination and omit some watersheds with significant contamination. However, given available data, EPA believes it represents a reasonable screening analysis to identify watersheds where further study is warranted.

The application of this procedure identified 96 watersheds that contain APCs. The location of these watersheds is depicted on Figure 3-7. The name and cataloging unit number on Table 3-4 correspond to the labels on Figure 3-7. These watersheds represent about 5 percent of all watersheds in the continental United States (96 of 2,111). The watershed analysis also indicated that 39 percent of all watersheds in the country contain at least one Tier 1 sampling station, 15 percent contain at least one Tier 2 sampling station but no Tier 1 stations, and 6 percent contain all Tier 3 sampling stations (Figure 3-8). Thirty-five percent of all watersheds in the country did not include a sampling station.

The definition of an APC requires that a watershed include at least 10 sampling stations, because at least 10 must be classified as Tier 1. About one-quarter of the watersheds in the country (488 of 2,111) met this requirement, and thus were eligible to contain an APC: approximately 20 percent (96 of 488) of these contain APCs. Although a minimum amount of sampling was required

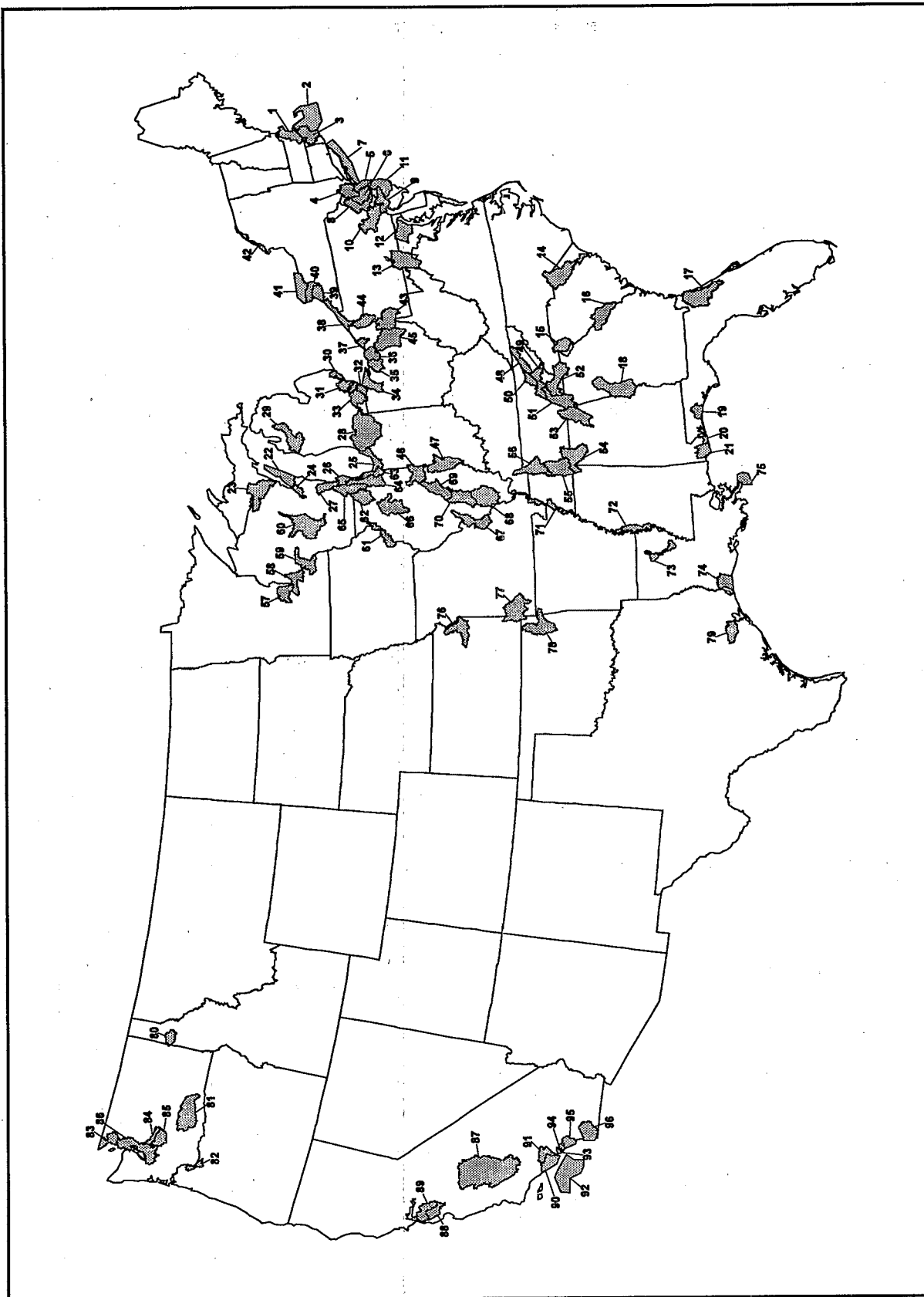

Figure 3-7. Watersheds Identified as Containing APCs

Table 3-4. USGS Cataloging Unit Numbers and Names for Watersheds Containing APCs

Map #	Cataloging Unit Number	Cataloging Unit Name
1	1090001	Charles
2	1090002	Cape Cod
3	1090004	Narragansett
4	2030103	Hackensack-Passaic
5	2030104	Sandy Hook-Staten Island
6	2030105	Raritan
7	2030202	Southern Long Island
8	2040105	Middle Delaware-Musconetcong
9	2040202	Lower Delaware
10	2040203	Schuylkill
11	2040301	Mullica-Toms
12	2060003	Gunpowder-Patapsco
13	2070004	Conococheague-Opequon
14	3040201	Lower Pee Dee
15	3060101	Seneca
16	3060106	Middle Savannah
17	3080103	Lower St. Johns
18	3130002	Middle Chattahoochee-Lake Harding
19	3140102	Choctawhatchee Bay
20	3140107	Perdido Bay
21	3160205	Mobile Bay
22	4030102	Door-Kewaunee
23	4030108	Menominee
24	4030204	Lower Fox
25	4040001	Little Calumet-Galien
26	4040002	Pike-Root
27	4040003	Milwaukee
28	4050001	St. Joseph
29	4060103	Manistee
30	4090002	Lake St. Clair
31	4090004	Detroit
32	4100001	Ottawa-Stony
33	4100002	Raisin
34	4100010	Cedar-Portage
35	4100012	Huron-Vermillion
36	4110001	Black-Rocky
37	4110003	Ashtabula-Chagrin

Table 3-4. (continued)

Map #	Cataloging Unit Number	Cataloging Unit Name
38	4120101	Chautauqua-Conneaut
39	4120103	Buffalo-Eighteenmile
40	4120104	Niagara
41	4130001	Oak Orchard-Twelve-mile
42	4150301	Upper St. Lawrence
43	5030101	Upper Ohio
44	5030102	Shenango
45	5040001	Tuscarawas
46	5120109	Vermilion
47	5120111	Middle Wabash-Busseron
48	6010104	Holston
49	6010201	Watts Bar Lake
50	6010207	Lower Clinch
51	6020001	Middle Tennessee-Chickamauga
52	6020002	Hiwassee
53	6030001	Guntersville Lake
54	6030005	Pickwick Lake
55	6040001	Lower Tennessee-Beech
56	6040005	Kentucky Lake
57	7010206	Twin Cities
58	7040001	Rush-Vermillion
59	7040003	Buffalo-Whitewater
60	7070003	Castle Rock
61	7080101	Copperas-Duck
62	7090006	Kishwaukee
63	7120003	Chicago
64	7120004	Des Plaines
65	7120006	Upper Fox
66	7130001	Lower Illinois-Senachwine Lake
67	71401001	Cahokia-Joachim
68	7140106	Big Muddy
69	7140201	Upper Kaskaskia
70	7140202	Middle Kaskaskia
71	8010100	Lower Mississippi-Memphis
72	8030209	Deer-Steele
73	8040207	Lower Ouachita

Table 3-4. (continued)

Map #	Cataloging Unit Number	Cataloging Unit Name
74	8080206	Lower Calcasieu
75	8090100	Lower Mississippi-New Orleans
76	10270104	Lower Kansas
77	11070207	Spring
78	11070209	Lower Neosho
79	12040104	Buffalo-San Jacinto
80	17010303	Coeur D'Alene Lake
81	17030003	Lower Yakima
82	17090012	Lower Willamette
83	17110002	Strait of Georgia
84	17110013	Duwamish
85	17110014	Puyallup
86	17110019	Puget Sound
87	18030012	Tulare-Buena Vista Lakes
88	18050003	Coyote
89	18050004	San Francisco Bay
90	18070104	Santa Monica Bay
91	18070105	Los Angeles
92	18070107	San Pedro Channel Islands
93	18070201	Seal Beach
94	18070204	Newport Bay
95	18070301	Aliso-San Onofre
96	18070304	San Diego

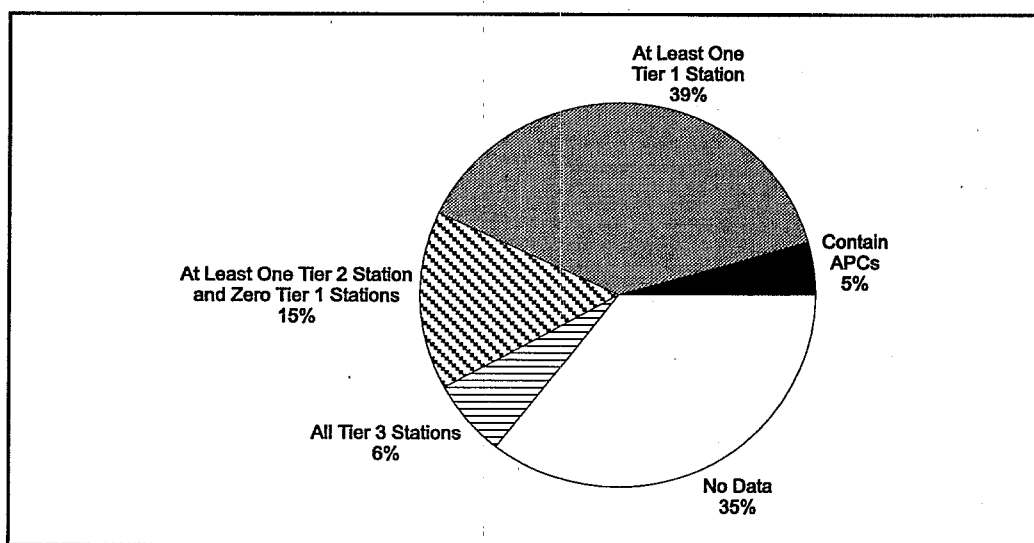

Figure 3-8. National Assessment: Watershed Classifications.

for consideration as an APC, sampling effort alone did not determine APC identification. In fact, other than defining a ceiling, the total number of sampling stations in a watershed is not indicative of the number of Tier 1 sampling stations. A simple statistical regression analysis of total number of sampling stations versus number of Tier 1 sampling stations for the nearly 500 watersheds eligible to contain an APC (including at least 10 and up to 200 sampling stations) resulted in a correlation coefficient (R-square) of 0.44, a value which indicates a large amount of variation.

APC designation could result from extensive sampling throughout a watershed, or from intensive sampling at a single or few contaminated locations. In comparison to the overall results presented in Figure 1, sampling stations are located on an average of 46 percent of reaches within watersheds containing APCs. On the average, 30 percent of reaches in watersheds containing APCs have at least one Tier 1 sampling station, and 13 percent have no Tier 1 sampling station but at least one Tier 2 sampling station. In many of these watersheds, contaminated areas may be concentrated in specific river reaches in a watershed. Within the 96 watersheds containing APCs across the country, 57 individual river reaches or water body segments have 10 or more Tier 1 sampling stations (Table 3-5). These are localized areas within the watershed for which an abundance of evidence indicates potentially severe contamination. Because EPA's Reach File 1 was used to index the location of NSI sampling stations, some sampling stations might not actually occur on the identified Reach File 1 stream, but on a smaller stream that is hydrologically linked or is relatively close to the Reach File 1 stream.

Volume 2 of this report contains more detailed information for each watershed containing an APC. This information includes maps showing watershed boundaries, major waterways (RF1), and the location and classification of sampling stations. In addition, Volume 2 provides tables summarizing the sediment chemistry, fish tissue, and toxicity test data collected within those watersheds that were used for this evaluation.

Wildlife Assessment

As described in Chapter 2, EPA conducted a separate analysis of the NSI data to determine the number of sampling stations where chemical concentrations of DDT, mercury, dioxin, and PCBs exceeded levels set to be protective of wildlife (i.e., EPA wildlife criteria). The wildlife criteria used in this evaluation were derived from those presented in the *Great Lakes Water Quality Initiative Criteria Documents for the Protection of Wildlife*

(USEPA, 1995a) subtracting out exposure from direct water consumption. The only assumed route of exposure for this evaluation was the consumption of contaminated fish tissue by wildlife.

Data were available to evaluate a total of 13,691 NSI sampling stations using the wildlife criteria. Based on wildlife criteria alone, 162 sampling stations would be classified as Tier 1 (matched sediment chemistry and fish tissue data), and 7,634 sampling stations would be classified as Tier 2 (sediment chemistry TBP or fish tissue data). Figure 3-9 shows the location of Tier 1 and Tier 2 sampling stations based on exceedance of wildlife criteria. Table 3-6 presents a comparison of the sampling stations classified as Tier 1 or Tier 2 with and without the use of wildlife criteria. If wildlife criteria had been used to complete the national assessment, 619 sampling stations classified as Tier 3 would have been classified as Tier 2 and 16 sampling stations classified as Tier 2 would have been classified as Tier 1. Most of the change is from an increase in Tier 2 sampling stations classified for DDT (from 2,619 to 4,276) and mercury (from 3,211 to 5,199).

Additional sampling stations would be classified as Tier 1 or Tier 2 using wildlife criteria for two reasons: (1) the wildlife criteria for DDT and mercury are significantly lower (8 and 19 times lower, respectively) than the EPA risk levels used in the corresponding human health evaluations; (2) the lipid content used in the wildlife TBP analysis (10.31 percent for whole body) exceeded the lipid content used in the human health TBP analysis (3.0 percent for fillet).

No additional sampling stations would be classified as Tier 1 based on mercury or dioxins wildlife criteria. For a sampling station to be classified as Tier 1, both sediment chemistry TBP and measured fish tissue concentrations taken from that sampling station had to exceed the wildlife criteria. At very few sampling stations in the NSI were both sediment chemistry and fish tissue levels for dioxin measured. In those few cases where contaminants in both media were measured, there were no additional sampling stations (stations not already classified as Tier 1) where both the sediment chemistry TBP and fish tissue levels exceeded the wildlife dioxin criteria. No additional sampling stations were classified as Tier 1 for exceedance of the wildlife criteria for mercury because sediment chemistry TBPs cannot be calculated for metals.

Regional and State Assessment

The remainder of this chapter presents more detailed results from the evaluation of NSI data for sam-

Table 3-5. River Reaches With 10 or More Tier 1 Sampling Stations Located in Watersheds Containing APCs

EPA Region	Cataloging Unit Number	Cataloging Unit Name	RF1 Reach ID	RF1 Reach Name	Number of Tier 1 Stations	Total Number of Stations in Reach
1	01090001	Charles	01090001022	Boston Bay	72	146
			01090001015	Boston Bay	42	149
			01090001013	Atlantic Ocean	37	58
			01090001024	Boston Bay	16	45
1	01090004	Narragansett	01090004023	Seekonk River	16	17
2	02030103	Hackensack-Passaic	02030103023	Rockaway River	26	56
2	02030104	Sandy Hook-Staten Island	02030104003	Arthur Kill	10	10
2	04120103	Buffalo-Eighteenmile	04120103007	Buffalo Creek	26	42
			04120103001	Lake Erie, U.S. Shore	17	22
2	04120104	Niagara	04120104007	Niagara River	12	20
2	04130001	Oak Orchard-Twelveville	04130001001	Lake Ontario, U.S. Shore	14	27
4	03060106	Middle Savannah	03060106047	Horse Creek	10	11
4	03080103	Lower St. Johns	03080103017	St. Johns River	10	27
4	06010201	Watts Bar Lake	06010201026	Little River	15	23
			06010201035	Tennessee River	10	12
4	06010207	Lower Clinch	06010207022	Poplar Creek	19	25
			06010207021	Poplar Creek, Brushy Fork	17	23
			06010207003	Clinch River	16	20
4	06020001	Middle Tennessee-Chickamauga	06020001003	Lookout Creek	29	41
4	06030005	Pickwick Lake	06030005046	Wilson Lake	22	25
5	04030108	Menominee	04030108001	Menominee River	10	12
5	04030204	Lower Fox	04030204001	Fox River	13	13
			04030204010	Fox River	12	13
			04030204004	Fox River	10	10
5	04040001	Little Cahumet-Galien	04040001010	Indiana Harbor	15	15
			04040001006	Cahumet River	12	20
5	04040002	Pike-Root	04040002002	Lake Michigan	15	33
5	04040003	Milwaukee	04040003001	Milwaukee River	48	64
5	04090004	Detroit	04090004006	Detroit River	27	38
			04090004014	River Rouge	12	12
			04090004011	Detroit River	11	11
			04090004004	Detroit River	10	12
5	04100002	Raisin	04100002001	River Raisin	16	32

Table 3-5. (Continued)

EPA Region	Cataloging Unit Number	Cataloging Unit Name	RF1 Reach ID	RF1 Reach Name	Number of Tier 1 Stations	Total Number of Stations in Reach
5	07010206	Twin Cities	7010206001	Mississippi River	10	15
5	07120003	Chicago	7120003001	Chicago Sanitary Ship Canal	35	36
			7120003006	Little Calumet River	13	42
5	07120004	Des Plaines	7120004011	Des Plaines River	11	20
6	08040207	Lower Ouachita	8040207005	Bayou De Siard	11	11
6	08080206	Lower Calcasieu	8080206033	Calcasieu River	13	40
			8080206034	Bayou D'Inde	11	30
6	08090100	Lower Mississippi-New Orleans	8090100004	Mississippi River	13	23
9	18030012	Tulare-Buena Vista Lakes	18030012014	Kings River	10	12
9	18050004	San Francisco Bay	18050004001	San Francisco Bay	11	27
9	18070104	Santa Monica Bay	18070104003	Pacific Ocean	20	37
9	18070105	Los Angeles	18070105001	Los Angeles River	12	31
9	18070201	Seal Beach	18070201001	Pacific Ocean	18	47
9	18070204	Newport Bay	18070204002	San Diego Creek	11	22
9	18070304	San Diego	18070304014	San Diego Bay	30	46
10	17110002	Strait of Georgia	17110002019	Bellingham Bay	13	26
10	17110013	Duwamish	17110013003	Elliott Bay	41	100
10	17110019	Puget Sound	17110019086	Puget Sound	119	232
			17110019085	Puget Sound	105	264
			17110019068	Budd Inlet	41	112
			17110019084	Puget Sound	32	57
			17110019087	Puget Sound	32	164
			17110019020	Bainbridge Island	31	88
			17110019022	Sinclair Inlet	25	44

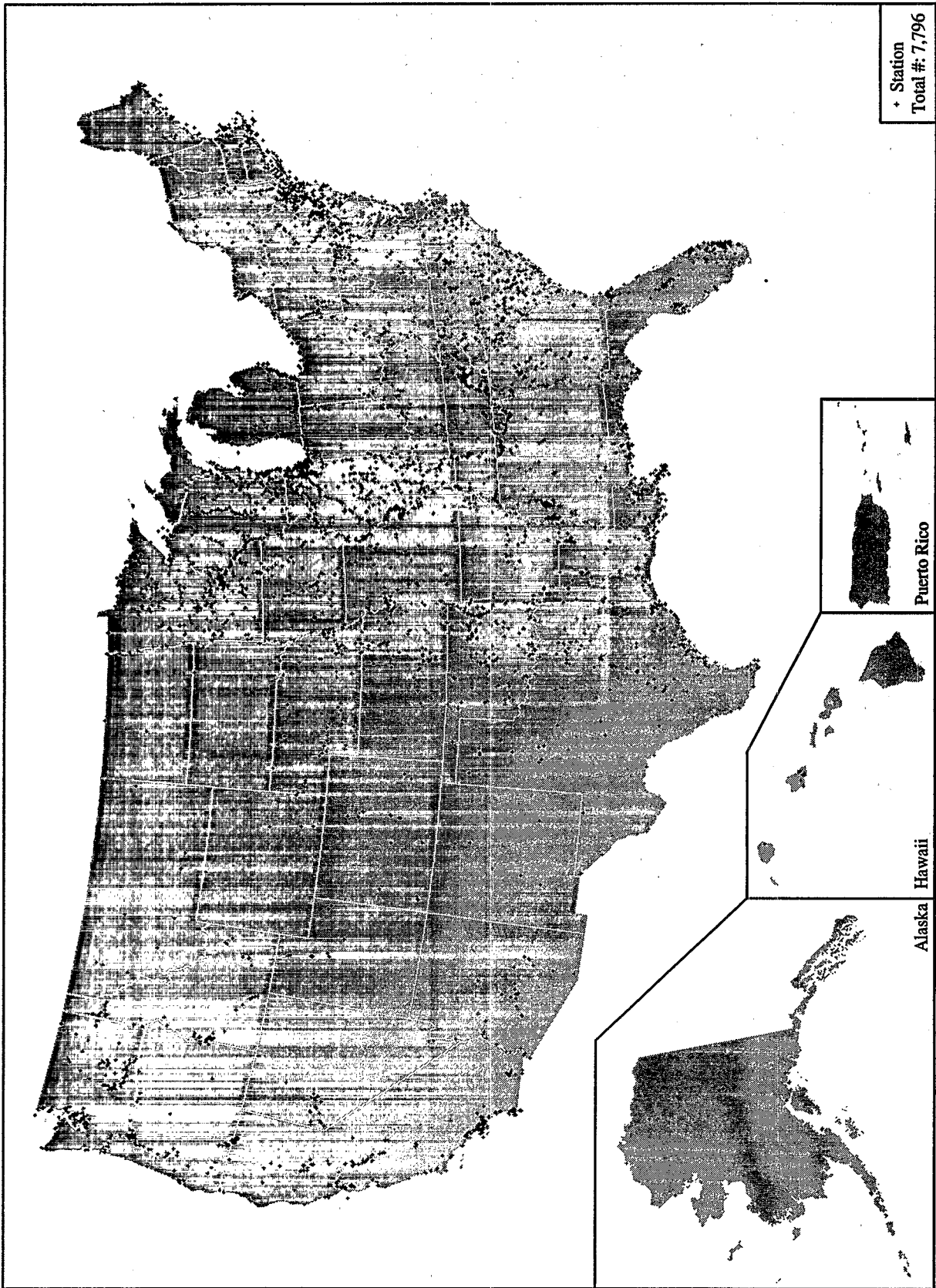

Figure 3-9. Sampling Stations Classified as Tier 1 or Tier 2 Based on Wildlife Criteria.

Table 3-6. Increased Number of Sampling Stations Classified as Tier 1 and Tier 2 by Including Wildlife Criteria in the National Assessment^a

Chemical or Chemical Group	Number of Stations Excluding Wildlife Assessment		Number of Stations Including Wildlife Assessment	
	Tier 1	Tier 2	Tier 1	Tier 2
DDT (and metabolites)	803	2,619	868	4,276
Dioxin	311	33	311	60
Mercury	1,122	3,211	1,122	5,199
PCBs	3,175	2,279	3,181	2,289
All Data	5,521	10,401	5,537	11,004

^aThe wildlife assessment used a default lipid content of 10.31 percent to compute the sediment chemistry TBP.

pling stations located in each of the EPA Regions and each state. The sections that follow present the number of Tier 1, Tier 2, and Tier 3 sampling stations in each Region and state and lists of the chemicals most often responsible for Tier 1 and Tier 2 classifications. Tables and figures similar to those presented in the national assessment of sampling station evaluation results and river reach evaluation results are included. Regional maps display the location of Tier 1 and Tier 2 sampling stations and APCs. The presentation format is identical for each Region.

These summary results are not inclusive of locations with contaminated sediment not identified in this survey. The data compiled for the NSI are primarily from large national electronic databases. Data from many sampling and testing studies have not yet been incorporated into the NSI. Thus, there might be additional locations

with sediment contamination that do not appear in this summary. On the other hand, data in the inventory were collected between 1980 and 1993 and any single measurement of chemical at a sampling station, taken any point in time during that period, could result in the classification of the sampling station in Tier 1 or Tier 2. Because the evaluation is a screening level analysis, sampling stations appearing in Tier 1 or Tier 2 might not cause unacceptable impacts. In addition, management programs to address identified sediment contamination might already exist.

It is important to emphasize here that some Regions, such as Region 4 and Region 5, have significantly more data in the NSI than do most other Regions. This would, to some degree, account for the relatively large number of sampling stations classified as Tier 1 in these Regions.

EPA Region 1

Connecticut, Maine, Massachusetts, New Hampshire, Rhode Island, Vermont

EPA evaluated 1,102 sampling stations in Region 1 as part of the NSI evaluation. Sediment contamination where associated adverse effects to aquatic life are probable (Tier 1) was found at 254 of these sampling stations, and possible but infrequent (Tier 2) at 613 of these sampling stations. For human health, data for 44 sampling stations indicated probable association with adverse effects (Tier 1), and 246 sampling stations indicated possible but infrequent adverse effects (Tier 2). Overall, this evaluation resulted in the classification of 298 sampling stations (27 percent) as Tier 1, 646 (59 percent) as Tier 2, and 158 (14 percent) as Tier 3. The NSI sampling stations in Region 1 were located in 131 separate river reaches, or 5 percent of all reaches in the Region. Two percent of all river reaches in Region 1 included at least one Tier 1 station, 3 percent included at least one Tier 2 station but no Tier 1 stations, and less than one percent had only Tier 3 stations (Figure 3-10). Table 3-7 (on the following page) presents a summary of sampling station classification and evaluation of river reaches for each state and for the Region as a whole.

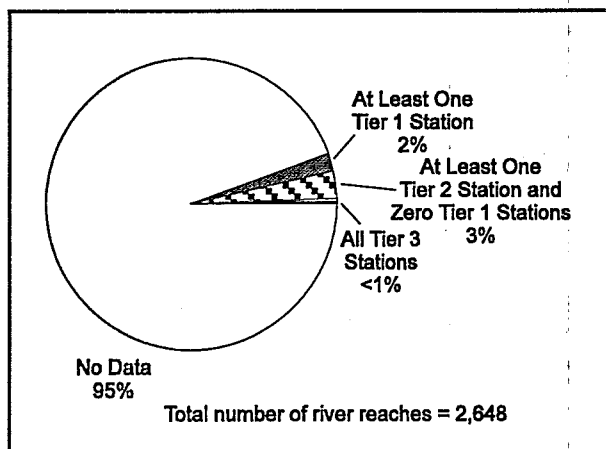

Figure 3-10. Region 1: Percent of River Reaches That Include Tier 1, Tier 2, and Tier 3 Sampling Stations.

This evaluation identified 3 watersheds containing areas of probable concern for sediment contamination (APCs) out of the 61 watersheds (5 percent) in Region 1 (Figure 3-11). In addition, 39 percent of all watersheds in the Region had at least one Tier 1 sampling station but were not identified as containing APCs, 11 percent had at least one Tier 2 station but no Tier 1 stations, and 2 percent had only Tier 3 stations. Forty-three percent of the watersheds in Region 1 did not include a sampling station. The locations of the watersheds containing APCs and the Tier 1 and Tier 2 sampling stations in Region 1 are illustrated in Figure 3-12.

Within the three watersheds in Region 1 identified as containing APCs (Table 3-8), 14 water bodies have at least 1 Tier 1 sampling station; 3 water bodies have 10 or more Tier 1 sampling stations (Table 3-9). The Massachusetts Bay area appears to have the most significant sediment contamination in Region 1. The water bodies listed on Table 3-9 are not inclusive of all locations containing a Tier 1 sampling station because only water bodies within watersheds containing APCs are listed.

The chemicals most often associated with Tier 1 and Tier 2 sampling station classifications in Region 1 overall and in each state in Region 1 are presented in Table 3-10.

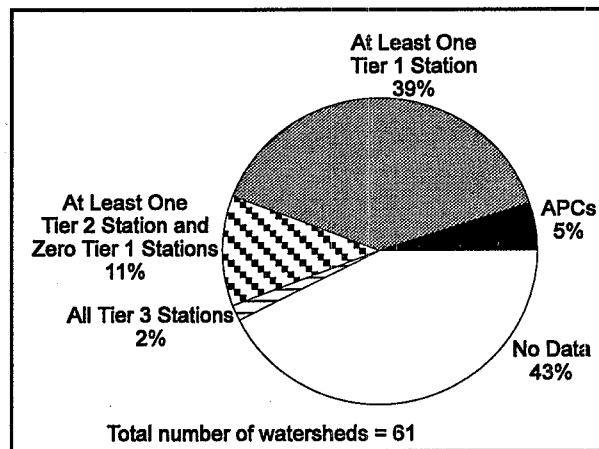

Figure 3-11. Region 1: Watershed Classifications.

Table 3-7. Region 1: Evaluation Results for Sampling Stations and River Reaches by State

State	Station Evaluation						River Reach Evaluation ^a							
	Tier 1		Tier 2		Tier 3		Number of Stations Not Identified by an RFI Reach ^b	Reaches w/ at Least 1 Station in Tier 1	Reaches w/ at Least 1 Station in Tier 2	Reaches w/ All Stations in Tier 3	Total # Reaches w/ at Least 1 Station Evaluated	Total Reaches in State	% of All Reaches in State w/ at Least 1 Station Evaluated	% of Reaches w/ at Least 1 or Tier 2 Station
	No.	%	No.	%	No.	%								
Connecticut	20	20	67	68	11	11	8	16	24	4	44	215	21	19
Maine	13	24	37	67	5	9	28	9	7	2	18	1,583	1	1
Massachusetts	242	27	516	58	137	15	316	25	27	-	52	270	19	19
New Hampshire	4	57	1	14	2	29	-	2	-	2	4	279	1	1
Rhode Island	16	38	24	57	2	5	9	6	7	-	13	56	23	23
Vermont	3	60	1	20	1	20	-	3	-	-	3	355	1	1
REGION 1 ^d	298	27	646	59	158	14	361	59	65	7	131	2,648	5	5

^aRiver reaches based on EPA River Reach File 1 (RFI).^bStations not identified by an RFI reach were located in coastal or open water areas.^cNo stations in these reaches were included in Tier 1.^dBecause some reaches occur in more than one state, the total number of reaches in each category for the Region might not equal the sum of reaches in the states.

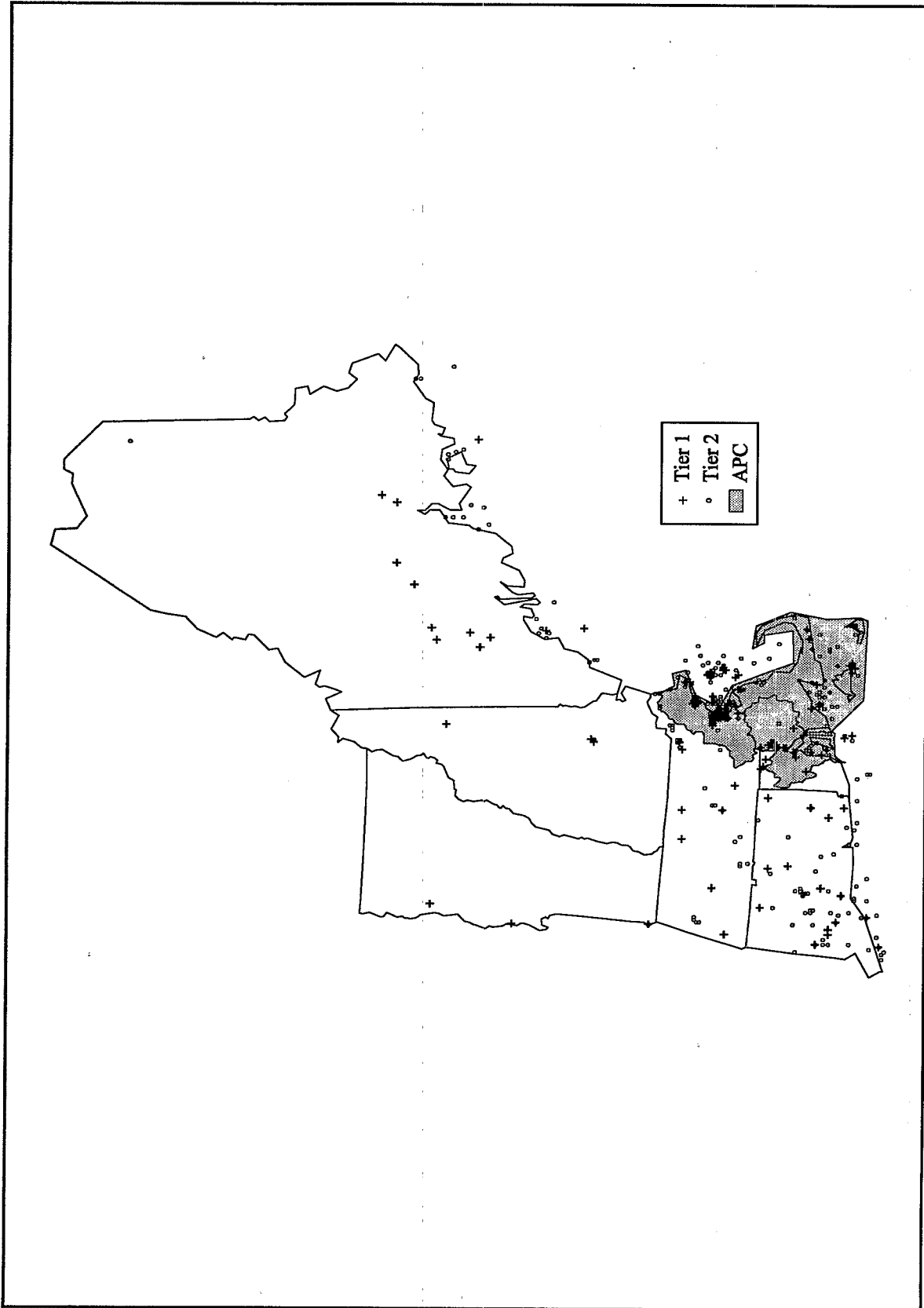

Figure 3-12. Region 1: Location of Sampling Stations Classified as Tier 1 or Tier 2 and Watersheds Containing Areas of Probable Concern for Sediment Contamination (APCs).

Table 3-8. Region 1: Watersheds Containing Areas of Probable Concern for Sediment Contamination

Cataloging Unit Number	Name	State(s) ^a	Number of Sampling Stations			Percent of Sampling Stations in Tier 1 or Tier 2
			Tier 1	Tier 2	Tier 3	
01090001	Charles	MA	195	402	111	84
01090004	Narragansett	MA, RI	28	20	0	100
01090002	Cape Cod	MA, (RI)	15	73	20	81

^aNo data were available for states listed in parenthesis

Table 3-9. Region 1: Water Bodies With Sampling Stations Classified as Tier 1 Located in Watersheds Containing APCs

Water Body	# of Tier 1 Stations	Water Body	# of Tier 1 Stations
Boston Bay	141	Bass River	3
Atlantic Ocean	46	Potowomut River	3
Seekonk River	16	Conanicut Island	2
Boston Harbor and Mystic River Area	9	Pawtuxet River	2
Buzzards Bay	5	Acushnet River	1
Martha's Vineyard*	4	Charles River	1
Narragansett Bay	4	Taunton River	1

*Subsequent data review indicates these sampling stations may, in fact, be located in Buzzards Bay.

Table 3-10. Region 1: Chemicals Most Often Associated With Tier 1 or Tier 2 Sampling Station Classifications*

	Chemical	# Tier 1 & Tier 2 Stations	# Tier 1 Station	# Tier 2 Station		Chemical	# Tier 1 & Tier 2 Stations	# Tier 1 Station	# Tier 2 Station	
Region 1 Overall	Copper	625	--	625	Massachusetts (continued)	Chromium	411	53	358	
	Lead	623	--	623		Nickel	377	--	377	
	Chromium	497	59	438		Arsenic	317	14	303	
	Nickel	491	--	491		Zinc	314	--	314	
	Mercury	488	176	312		Cadmium	278	--	278	
	Arsenic	387	14	373		Polychlorinated biphenyls	149	54	95	
	Zinc	376	--	376		Benzo(a)pyrene	98	2	96	
	Cadmium	339	--	339		New Hampshire	DDT	4	3	1
	Polychlorinated biphenyls	231	74	157			Anthracene	3	2	1
	Benzo(a)pyrene	179	5	174	Benzo(a)anthracene		3	2	1	
	DDT	133	17	116	Benzo(a)pyrene		3	2	1	
	Dibenzo(a,h)anthracene	132	13	119	Phenanthrene		3	2	1	
	Benzo(a)anthracene	128	8	120	Acenaphthylene		3	--	3	
	Pyrene	122	7	115	Benzo(b)fluoranthene		3	--	3	
	Chrysene	120	2	118	Fluoranthene		3	--	3	
	Connecticut	Copper	71	--	71	Chrysene	2	1	1	
Nickel		55	--	55	Acenaphthene	2	--	2		
Lead		49	--	49	Rhode Island	Lead	35	--	35	
Cadmium		45	--	45		Copper	32	--	32	
Zinc		40	--	40		Nickel	28	--	28	
Mercury		39	11	28		Polychlorinated biphenyls	25	5	20	
Chromium		32	--	32		Benzo(a)pyrene	25	--	25	
Benzo(a)pyrene		28	1	27		Chromium	23	3	20	
Chrysene		24	--	24		DDT	23	3	20	
Polychlorinated biphenyls	23	4	19	Arsenic		22	--	22		
Maine	Arsenic	31	--	31		Benzo(a)anthracene	21	--	21	
	Polychlorinated biphenyls	30	7	23	Dibenzo(a,h)anthracene	20	2	18		
	Chromium	30	2	28	Vermont	Polychlorinated biphenyls	3	3	--	
	Nickel	29	--	29		Dioxins	1	1	--	
	Benzo(a)pyrene	25	--	25		Aldrin	1	--	1	
	Lead	23	--	23		Arsenic	1	--	1	
	DDT	16	--	16		Cadmium	1	--	1	
	Copper	15	--	15		Copper	1	--	1	
	Mercury	13	--	13		Dieldrin	1	--	1	
Dibenzo(a,h)anthracene	12	1	11	Lead		1	--	1		
Massachusetts	Lead	513	--	513		Mercury	1	--	1	
	Copper	504	--	504	Nickel	1	--	1		
	Mercury	416	162	254						

*Stations may be listed for more than one chemical.

EPA Region 2

New Jersey, New York, Puerto Rico

EPA evaluated 1,096 sampling stations in Region 2 as part of the NSI evaluation. Sediment contamination where associated adverse effects to aquatic life are probable (Tier 1) was found at 319 of these sampling stations, and possible but infrequent (Tier 2) at 523 of these sampling stations. For human health, data for 37 sampling stations indicated probable association with adverse effects (Tier 1), and 533 sampling stations indicated possible but infrequent adverse effects (Tier 2). Overall, this evaluation resulted in the classification of 355 sampling stations (32 percent) as Tier 1, 559 (51 percent) as Tier 2, and 182 (17 percent) as Tier 3. The NSI sampling stations in Region 2 were located in 292 separate river reaches, or 17 percent of all reaches in the Region. Seven percent of all river reaches in Region 2 included at least one Tier 1 station, 8 percent included at least one Tier 2 station but no Tier 1 stations, and 2 percent had only Tier 3 stations (Figure 3-13). Table 3-11 (on the following page) presents a summary of sampling station classification and evaluation of river reaches for each state and for the Region as a whole.

This evaluation identified 12 watersheds containing areas of probable concern for sediment contamination (APCs) out of the 63 watersheds (19 percent) in Region 2 (Figure 3-14). In addition, 41 percent of all water-

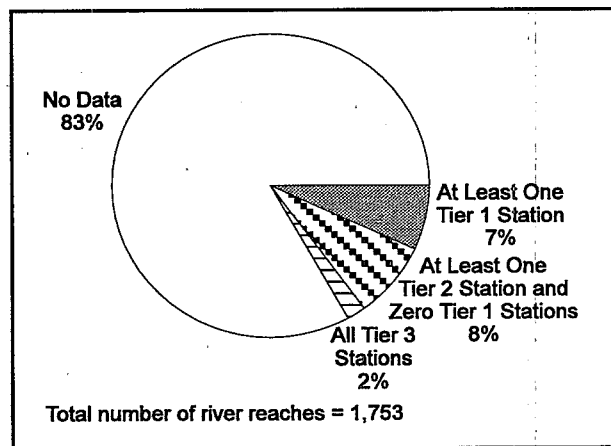

Figure 3-13. Region 2: Percent of River Reaches That Include Tier 1, Tier 2, and Tier 3 Sampling Stations.

sheds in the Region had at least one Tier 1 sampling station but were not identified as containing APCs, 30 percent had at least one Tier 2 station but no Tier 1 stations, and none of the watersheds evaluated had only Tier 3 stations. Ten percent of the watersheds in Region 2 did not include a sampling station. The locations of the watersheds containing APCs and the Tier 1 and Tier 2 sampling stations in Region 2 are illustrated in Figure 3-15.

Within the 12 watersheds in Region 2 identified as containing APCs (Table 3-12), 52 water bodies have at least 1 Tier 1 sampling station; 9 water bodies have 10 or more Tier 1 sampling stations (Table 3-13). Several areas in Region 2 appear to have significant sediment contamination. They include the Niagara River, Buffalo Creek, and Lake Erie near Buffalo, New York; Lake Ontario between Rochester, New York, and the Niagara River; the St. Lawrence River in the northern part of New York; Arthur Kill in New York and New Jersey; the Hackensack/Passaic watershed in New York and New Jersey; the Atlantic Ocean beyond Staten Island; and others. The water bodies listed on Table 3-13 are not inclusive of all locations containing a Tier 1 sampling station because only water bodies within watersheds containing APCs are listed.

The chemicals most often associated with Tier 1 and Tier 2 sampling station classifications in Region 2 overall and in each state in Region 2 are presented in Table 3-14.

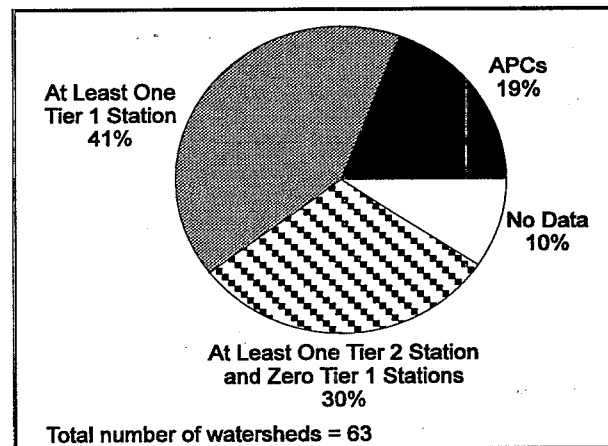

Figure 3-14. Region 2: Watershed Classifications.

Table 3-11. Region 2: Evaluation Results for Sampling Stations and River Reaches by State

State	Station Evaluation						River Reach Evaluation ^a							
	Tier 1		Tier 2		Tier 3		Number of Stations Not Identified by an RFI Reach ^b	Reaches w/at Least 1 Station in Tier 1	Reaches w/at Least 1 Station in Tier 2 ^c	Reaches w/all Stations in Tier 3	Total # Reaches w/at Least 1 Station Evaluated	Total Reaches in State	% of all Reaches in State w/at Least 1 Station Evaluated	% of Reaches w/at Least 1 or Tier 2 Station
	No.	%	No.	%	No.	%								
New Jersey	142	32	228	51	78	17	62	59	56	14	129	285	45	40
New York	208	34	310	50	100	16	81	58	93	15	166	1,488	11	10
Puerto Rico	5	17	21	70	4	13	30	-	-	-	-	-	-	-
REGION 2 ^d	355	32	559	51	182	17	173	116	147	29	292	1,753	17	15

^aRiver reaches based on EPA River Reach File 1 (RF1).

^bStations not identified by an RFI reach were located in coastal or open water areas.

^cNo stations in these reaches were included in Tier 1.

^dBecause some reaches occur in more than one state, the total number of reaches in each category for the Region might not equal the sum of reaches in the states.

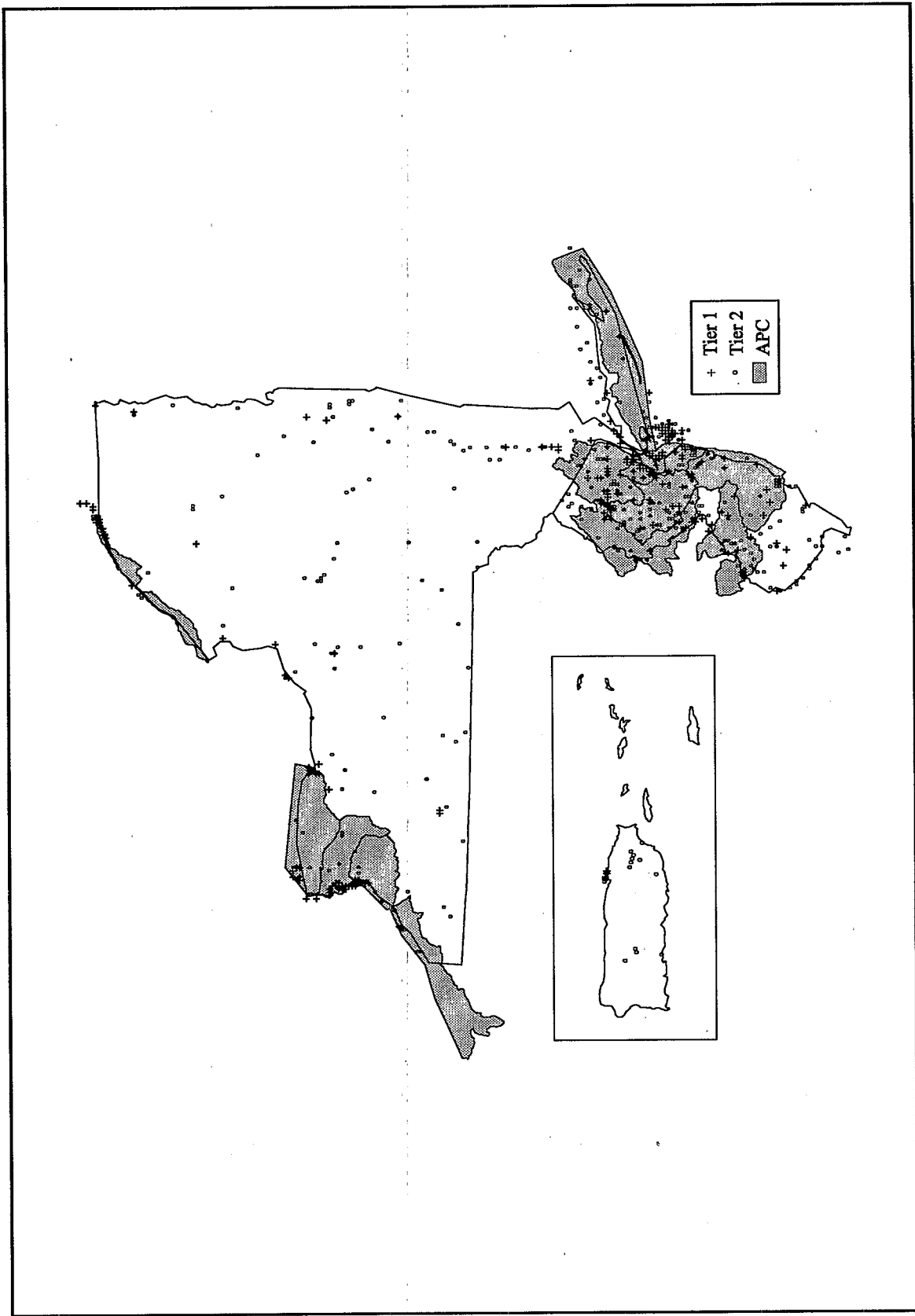

Figure 3-15. Region 2: Location of Sampling Stations Classified as Tier 1 or Tier 2 and Watersheds Containing Areas of Probable Concern for Sediment Contamination (APCs).

Table 3-12. Region 2: Watersheds Containing Areas of Probable Concern for Sediment Contamination

Cataloging Unit Number	Name	State(s) ^a	Number of Sampling Stations			Percent of Sampling Stations in Tier 1 or Tier 2
			Tier 1	Tier 2	Tier 3	
02030104	Sandy Hook-Staten Island	NY, NJ	60	21	19	81
04120103	Buffalo-Eighteenmile	NY	59	33	9	91
02030103	Hackensack-Passaic	NY, NJ	43	58	2	98
04130001	Oak Orchard-Twelve-mile	NY	39	46	1	99
04120104	Niagara	NY	24	16	1	98
04120101	Chautauqua-Conneaut	NY, PA, OH	21	86	3	97
04150301	Upper St. Lawrence	NY	21	5	5	84
02040202	Lower Delaware	PA, NJ	18	29	10	82
02030105	Raritan	NJ	13	37	15	77
02030202	Southern Long Island	NY	11	24	8	81
02040105	Middle Delaware-Musconetcong	PA, NJ	11	26	11	77
02040301	Mullica-Toms	NJ	10	22	10	76

Table 3-13. Region 2: Water Bodies With Sampling Stations Classified as Tier 1 Located in Watersheds Containing APCs

Water Body	# of Tier 1 Stations	Water Body	# of Tier 1 Stations
Lake Ontario, U.S. Shore	31	Shrewsbury River	2
Buffalo Creek	30	Stony Bk.	2
Rockaway River	26	Bass River	1
Lake Erie, U.S. Shore	24	Beden Brook	1
Atlantic Ocean	22	Big Timber Creek	1
Niagara River	21	Cazenovia Creek	1
St. Lawrence River	21	Cooper River	1
Arthur Kill	10	Cranbury Bk.	1
Staten Island	10	Great South Bay	1
Sandy Hook Bay	8	Green Bk.	1
Delaware River	8	Hammonton Creek	1
Newark Bay	6	Matchaponix Bk.	1
Smoke Creek	6	Millstone River	1
Passaic River	6	Mullica River	1
Hackensack River	5	Rahway River	1
Manasquan River	4	Rancocas Creek, N. Br.	1
Musconetcong River	3	Raritan Bay	1
Tonawanda Creek	3	Raritan River, N. Br.	1
Barneгат Bay	2	Raritan River, S. Br.	1
Eighteen-mile Creek	2	SB Rockaway Creek	1
Lower Bay	2	Shinnecock Bay	1
Manalapan Bk.	2	South River	1
Moriches Bay	2	Toms River	1
Pompton Creek	2	Wanaque Reservoir	1
Rancocas Creek, S. Br.	2	Whippany River	1
Saddle River	2	Yellow Brook	1

Table 3-14. Region 2: Chemicals Most Often Associated With Tier 1 or Tier 2 Sampling Station Classifications^a

	Chemical	# Tier 1 & Tier 2 Stations	# Tier 1 Station	# Tier 2 Station		Chemical	# Tier 1 & Tier 2 Stations	# Tier 1 Station	# Tier 2 Station
Region 2 Overall	Copper	546	--	546	New Jersey (continued)	Cadmium	128	--	128
	Lead	467	--	467		Chromium	119	22	97
	Nickel	443	--	443	New York	Copper	332	--	332
	Polychlorinated biphenyls	442	151	291		Nickel	321	--	321
	Mercury	388	144	244		Lead	268	--	268
	Cadmium	360	--	360		Polychlorinated biphenyls	261	108	153
	Zinc	358	--	358		Cadmium	230	--	230
	DDT	351	114	237		Mercury	224	70	154
	Arsenic	282	6	276		Zinc	210	--	210
	Chromium	247	26	221		DDT	155	66	89
	Chlordane	229	--	229		Pyrene	147	52	95
	Pyrene	214	64	150		Chromium	126	4	122
	Benzo(a)pyrene	180	36	144	Puerto Rico	Copper	22	--	22
	Naphthalene	155	30	125		Nickel	10	--	10
	Fluoranthene	151	41	110		Arsenic	9	--	9
New Jersey	DDT	195	48	147		Lead	8	--	8
	Copper	192	--	192		Mercury	6	4	2
	Lead	191	--	191		Zinc	5	--	5
	Polychlorinated biphenyls	181	43	138		Silver	4	1	3
	Mercury	158	70	88		Bis(2-ethylhexyl)phthalat	2	1	1
	Arsenic	151	6	145		Diethyl phthalate	2	1	1
	Zinc	143	--	143		Cadmium	2	--	2
	Chlordane	139	--	139					

^aStations may be listed for more than one chemical.

EPA Region 3

Delaware, District of Columbia, Maryland, Pennsylvania, Virginia, West Virginia

EPA evaluated 1,910 sampling stations in Region 3 as part of the NSI evaluation. Sediment contamination where associated adverse effects to aquatic life are probable (Tier 1) was found at 86 of these sampling stations, and possible but infrequent (Tier 2) at 915 of these sampling stations. For human health, data for 239 sampling stations indicated probable association with adverse effects (Tier 1), and 222 sampling stations indicated possible but infrequent adverse effects (Tier 2). Overall, this evaluation resulted in the classification of 318 sampling stations (17 percent) as Tier 1, 934 (49 percent) as Tier 2, and 658 (34 percent) as Tier 3. The NSI sampling stations in Region 3 were located in 888 separate river reaches, or 27 percent of all reaches in the Region. Six percent of all river reaches in Region 3 included at least one Tier 1 station, 14 percent included at least one Tier 2 station but no Tier 1 stations, and 7 percent had only Tier 3 stations (Figure 3-16). Table 3-15 (on the following page) presents a summary of sampling station classification and evaluation of river reaches for each state and for the Region as a whole.

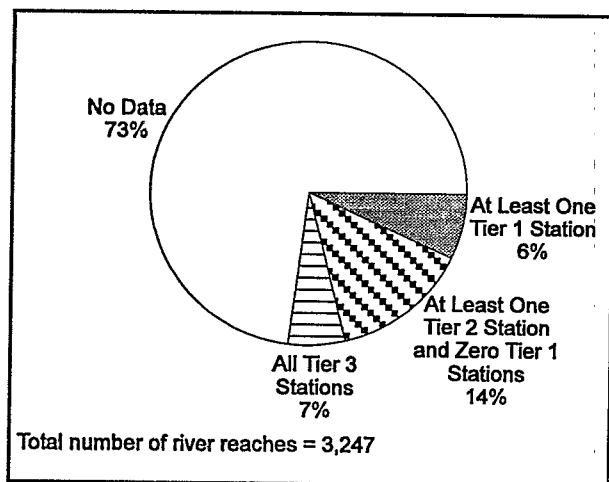

Figure 3-16. Region 3: Percent of River Reaches That Include Tier 1, Tier 2 and Tier 3 Sampling Stations.

This evaluation identified 8 watersheds containing areas of probable concern for sediment contamination (APCs) out of the 128 watersheds (6 percent) in Region 3 (Figure 3-17). In addition, 63 percent of all watersheds in the Region had at least one Tier 1 sampling station but were not identified as containing APCs, 22 percent had at least one Tier 2 station but no Tier 1 stations, and 5 percent had only Tier 3 stations. Four percent of the watersheds in Region 3 did not include a sampling station. The locations of the watersheds containing APCs and the Tier 1 and Tier 2 sampling stations in Region 3 are illustrated in Figure 3-18.

Within the 8 watersheds in Region 3 identified as containing APCs (Table 3-16), 27 water bodies have at least 1 Tier 1 sampling station; 4 water bodies have 10 or more Tier 1 sampling stations (Table 3-17). The Delaware River; the Schuylkill River in Pennsylvania (near Philadelphia); coastal areas of Lake Erie near Erie, Pennsylvania; and the Ohio River near Pittsburgh appear to have some of the most significant sediment contamination in Region 3. The water bodies listed on Table 3-17 are not inclusive of all locations containing a Tier 1 station because only water bodies within watersheds containing APCs are listed.

The chemicals most often associated with Tier 1 and Tier 2 sampling station classifications in Region 3 overall and in each state in Region 3 are presented in Table 3-18.

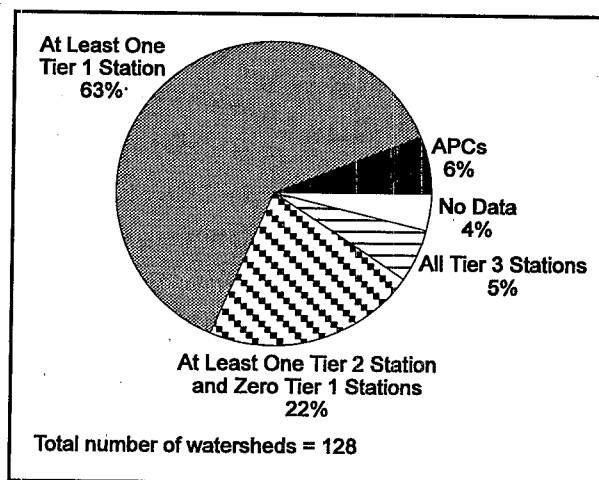

Figure 3-17. Region 3: Watershed Classifications.

Table 3-15. Region 3: Evaluation Results for Sampling Stations and River Reaches by State

State	Station Evaluation						River Reach Evaluation ^a							
	Tier 1		Tier 2		Tier 3		Number of Stations Not Identified by an RFI Reach ^b	Reaches w/at Least 1 Station in Tier 1	Reaches w/at Least 1 Station in Tier 2 ^c	Reaches w/all Stations in Tier 3	Total # Reaches w/at Least 1 Station Evaluated	Total Reaches in State	% of all Reaches in State w/at Least 1 Station Evaluated	% of Reaches w/at Least 1 or Tier 2 Station
	No.	%	No.	%	No.	%								
Delaware	21	10	35	16	162	74	13	10	7	22	39	77	51	22
District of Columbia	3	75	1	25	-	-	-	3	-	-	3	11	27	27
Maryland	50	24	68	33	88	43	29	31	36	30	97	400	24	17
Pennsylvania	127	41	106	34	78	25	4	78	27	34	139	677	21	16
Virginia	73	7	691	66	287	27	46	61	362	112	535	1279	42	33
West Virginia	44	37	33	27	43	36	-	30	23	31	84	993	9	5
REGION 3 ^d	318	17	934	49	658	34	92	209	453	226	888	3247	27	20

^aRiver reaches based on EPA River Reach File 1 (RFI).^bStations not identified by an RFI reach were located in coastal or open water areas.^cNo stations in these reaches were included in Tier 1.^dBecause some reaches occur in more than one state, the total number of reaches in each category for the Region might not equal the sum of reaches in the states.

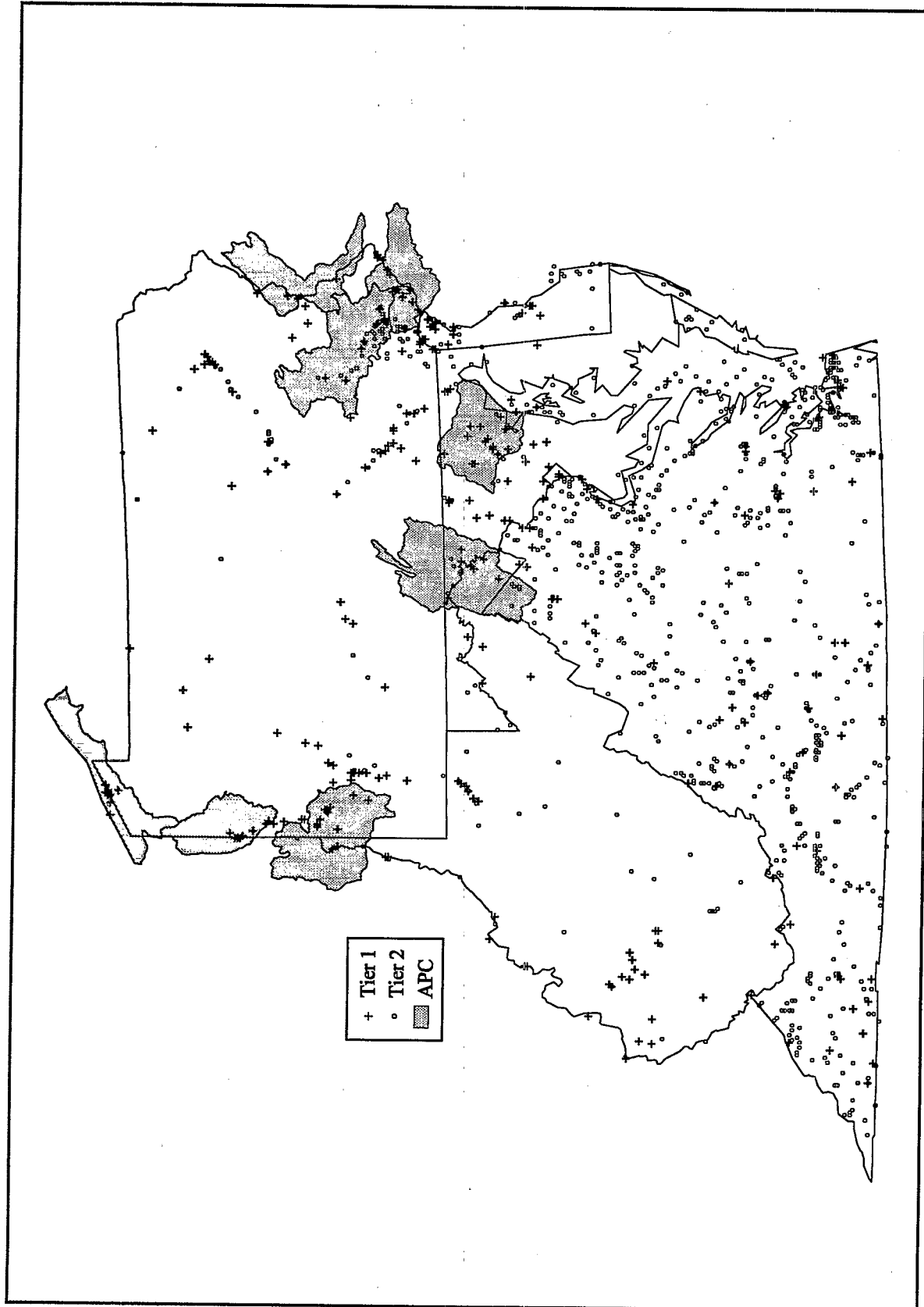

Figure 3-18. Region 3: Location of Sampling Stations Classified as Tier 1 of Tier 2 and Watersheds Containing Areas of Probable Concern for Sediment Contamination (APCs).

Table 3-16. Region 3: Watersheds Containing Areas of Probable Concern for Sediment Contamination

Cataloging Unit Number	Name	State(s) ^a	Number of Sampling Stations			Percent of Sampling Stations in Tier 1 or Tier 2
			Tier 1	Tier 2	Tier 3	
04120101	Chautauqua-Conneaut	NY,PA,OH	21	86	3	97
02040202	Lower Delaware	PA,NJ	18	29	10	82
02060003	Gunpowder-Patapsco	MD,(PA)	17	7	5	83
02040203	Schuylkill	PA	12	23	9	80
05030101	Upper Ohio	WV,PA,OH	12	29	12	77
02040105	Middle Delaware-Musconetcong	PA,NJ	11	26	11	77
02070004	Conococheague-Opequon	WV,VA,MD,(P-A)	11	12	6	79
05030102	Shenango	OH,PA	11	1	3	80

^aNo data were available for states listed in parentheses.

Table 3-17. Region 3: Water Bodies With Sampling Stations Classified as Tier 1 Located in Watersheds Containing APCs

Water Body	# of Tier 1 Stations	Water Body	# of Tier 1 Stations
Delaware River	13	Patapsco River	2
Lake Erie, U.S. Shore	10	Patapsco River, N. Br.	2
Schuylkill River	10	Raccoon Creek	2
Shenango River	10	Back River	1
Ohio River	7	Chesapeake Bay	1
Gunpowder Falls	4	Crum Creek	1
Potomac River	4	Darby Creek	1
Opequon Creek	3	Little Chartiers Creek	1
Antietam Creek	2	Little Gunpowder Falls	1
Chartiers Creek	2	Neshannock Creek	1
Conococheague Creek	2	Tulpehocken Creek	1
Curtis Bay	2	Walnut Creek	1
Gwynns Falls	2	Wassahickon Creek	1
Herring Run	2		

Table 3-18. Region 3: Chemicals Most Often Associated With Tier 1 or Tier 2 Sampling Station Classifications*

	Chemical	# Tier 1 & Tier 2 Stations	# Tier 1 Station	# Tier 2 Station		Chemical	# Tier 1 & Tier 2 Stations	# Tier 1 Station	# Tier 2 Station	
Region 3 Overall	Nickel	634	--	634	Maryland (continued)	Nickel	50	--	50	
	Copper	626	--	626		Copper	42	--	42	
	Lead	626	--	626		Chromium	41	4	37	
	Arsenic	529	1	528		DDT	35	--	35	
	Zinc	371	--	371		Chlordane	33	--	33	
	Polychlorinated biphenyls	353	243	110		Zinc	32	--	32	
	Cadmium	346	--	346		Benzo(a)pyrene	31	--	31	
	Mercury	320	42	278		Pennsylvania	Polychlorinated biphenyls	141	112	29
	Chromium	249	12	237			Lead	87	--	87
	Chlordane	161	--	161	Chlordane		81	--	81	
	DDT	135	9	126	Nickel		63	--	63	
	Dieldrin	116	--	116	Cadmium		56	--	56	
	Benzo(a)pyrene	106	6	100	Dieldrin		55	--	55	
	BHC	69	2	67	Copper		46	--	46	
	Dibenzo(a,h)anthracene	64	4	60	Zinc		44	--	44	
	Delaware	Polychlorinated biphenyls	33	14	19		DDT	38	6	32
		DDT	27	3	24	Mercury	25	3	22	
Lead		24	--	24	Virginia	Copper	520	--	520	
Chromium		19	2	17		Nickel	497	--	497	
Arsenic		18	--	18		Arsenic	412	--	412	
Nickel		15	--	15		Lead	411	--	411	
BHC		13	--	13		Zinc	279	--	279	
Mercury		12	3	9		Mercury	260	34	226	
Benzo(a)pyrene		12	--	12		Cadmium	255	--	255	
Copper	8	--	8	Chromium		167	3	164		
District of Columbia	Polychlorinated biphenyls	4	2	2		Polychlorinated biphenyls	62	30	32	
	Dioxins	2	2	--	Benzo(a)pyrene	48	4	44		
	Benzo(a)pyrene	2	--	2	West Virginia	Polychlorinated biphenyls	42	41	--	
	Chlordane	2	--	2		Lead	35	--	35	
	Copper	2	--	2		Chlordane	29	--	29	
	Dieldrin	2	--	2		Dieldrin	16	--	16	
	Nickel	2	--	2		Cadmium	12	--	12	
	Silver	1	1	--		Copper	8	--	8	
	Arsenic	1	--	1		Zinc	8	--	8	
	Benzo(a)anthracene	1	--	1		Heptachlor epoxide	7	--	7	
Maryland	Polychlorinated biphenyls	71	44	27		Nickel	7	--	7	
	Arsenic	70	--	70		Aldrin	6	--	6	
	Lead	68	--	68						

*Stations may be listed for more than one chemical.

EPA Region 4

Alabama, Florida, Georgia, Kentucky, Mississippi, North Carolina, South Carolina, Tennessee

EPA evaluated 4,959 sampling stations in Region 4 as part of the NSI evaluation. Sediment contamination where associated adverse effects to aquatic life are probable (Tier 1) was found at 637 of these sampling stations, and possible but infrequent (Tier 2) at 1,888 of these sampling stations. For human health, data for 561 sampling stations indicated probable association with adverse effects (Tier 1), and 1,006 sampling stations indicated possible but infrequent adverse effects (Tier 2). Overall, this evaluation resulted in the classification of 1,157 sampling stations (23 percent) as Tier 1, 1,930 (39 percent) as Tier 2, and 1,872 (38 percent) as Tier 3. The NSI sampling stations in Region 4 were located in 1,770 separate river reaches, or 18 percent of all reaches in the Region. Six percent of all river reaches in Region 4 included at least one Tier 1 station, 7 percent included at least one Tier 2 station but no Tier 1 stations, and 5 percent had only Tier 3 stations (Figure 3-19). Table 3-19 (on the following page) presents a summary of sampling station classification and evaluation of river reaches for each state and for the Region as a whole.

This evaluation identified 19 watersheds containing areas of probable concern for sediment contamination

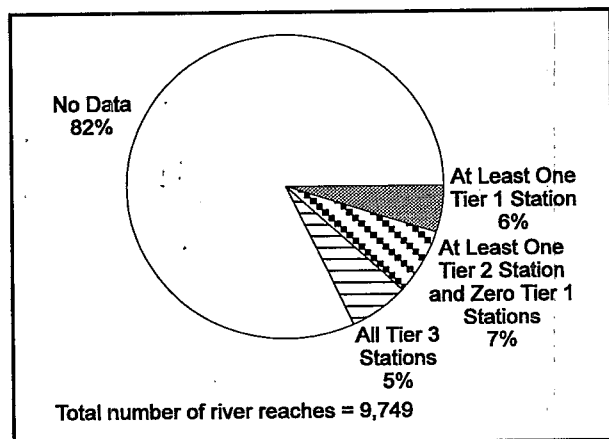

Figure 3-19. Region 4: Percent of River Reaches That Include Tier 1, Tier 2, and Tier 3 Sampling Stations.

(APCs) out of the 308 watersheds (6 percent) in Region 4 (Figure 3-20). In addition, 59 percent of all watersheds in the Region had at least one Tier 1 sampling station but were not identified as containing APCs, 17 percent had at least one Tier 2 station but no Tier 1 stations, and 8 percent had only Tier 3 stations. Ten percent of the watersheds in Region 4 did not include a sampling station. The locations of the watersheds containing APCs and the Tier 1 and Tier 2 sampling stations in Region 4 are illustrated in Figure 3-21.

Within the 19 watersheds in Region 4 identified as containing APCs (Table 3-20), 65 water bodies have at least 1 Tier 1 sampling station; 15 water bodies have 10 or more Tier 1 sampling stations (Table 3-21). Several areas in Region 4 appear to have potential sediment contamination. They include the Tennessee River and Lookout Creek in Tennessee and Georgia, Wilson Lake and Mobile Bay in Alabama, the St. Johns River in Florida, and other locations. The water bodies listed on Table 3-21 are not inclusive of all locations containing a Tier 1 sampling station because only water bodies within watersheds containing APCs are listed.

The chemicals most often associated with Tier 1 and Tier 2 sampling station classifications in Region 4 overall and in each state in Region 4 are presented in Table 3-22.

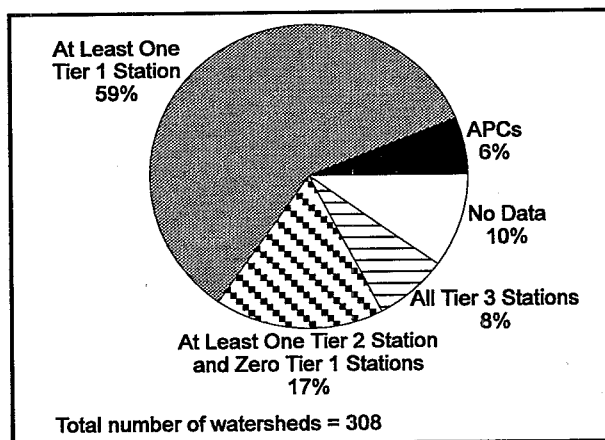

Figure 3-20. Region 4: Watershed Classifications.

Table 3-19. Region 4: Evaluation Results for Sampling Stations and River Reaches by State

State	Station Evaluation						River Reach Evaluation ^a							
	Tier 1		Tier 2		Tier 3		Number of Stations Not Identified by an RFI Reach ^b	Reaches w/ at Least 1 Station in Tier 1	Reaches w/ at Least 1 Station in Tier 2 ^c	Reaches w/ all Stations in Tier 3	Total # Reaches w/ at Least 1 Station Evaluated	Total Reaches in State	% of all Reaches in State w/ at Least 1 Station Evaluated	% of Reaches w/ at Least 1 Tier 1 or Tier 2 Station
	No.	%	No.	%	No.	%								
Alabama	160	34	178	37	139	29	65	68	57	57	182	1,531	12	8
Florida	211	12	672	38	893	50	190	70	115	126	311	855	36	22
Georgia	115	36	100	32	103	32	3	75	57	54	186	1,658	11	8
Kentucky	69	28	131	52	49	20	-	49	60	26	135	1,247	11	9
Mississippi	54	17	142	45	122	38	61	21	47	35	103	984	11	7
North Carolina	71	12	294	48	247	40	22	50	156	107	313	1,415	22	15
South Carolina	161	29	254	45	148	26	2	105	138	28	271	1,055	26	23
Tennessee	316	49	159	25	171	26	-	132	63	97	292	1,417	21	14
REGION 4 ^d	1,157	23	1,930	39	1,872	38	343	566	684	520	1,770	9,749	18	13

^aRiver reaches based on EPA River Reach File 1 (RFI).

^bStations not identified by an RFI reach were located in coastal or open water areas.

^cNo stations in these reaches were included in Tier 1.

^dBecause some reaches occur in more than one state, the total number of reaches in each category for the Region might not equal the sum of reaches in the states.

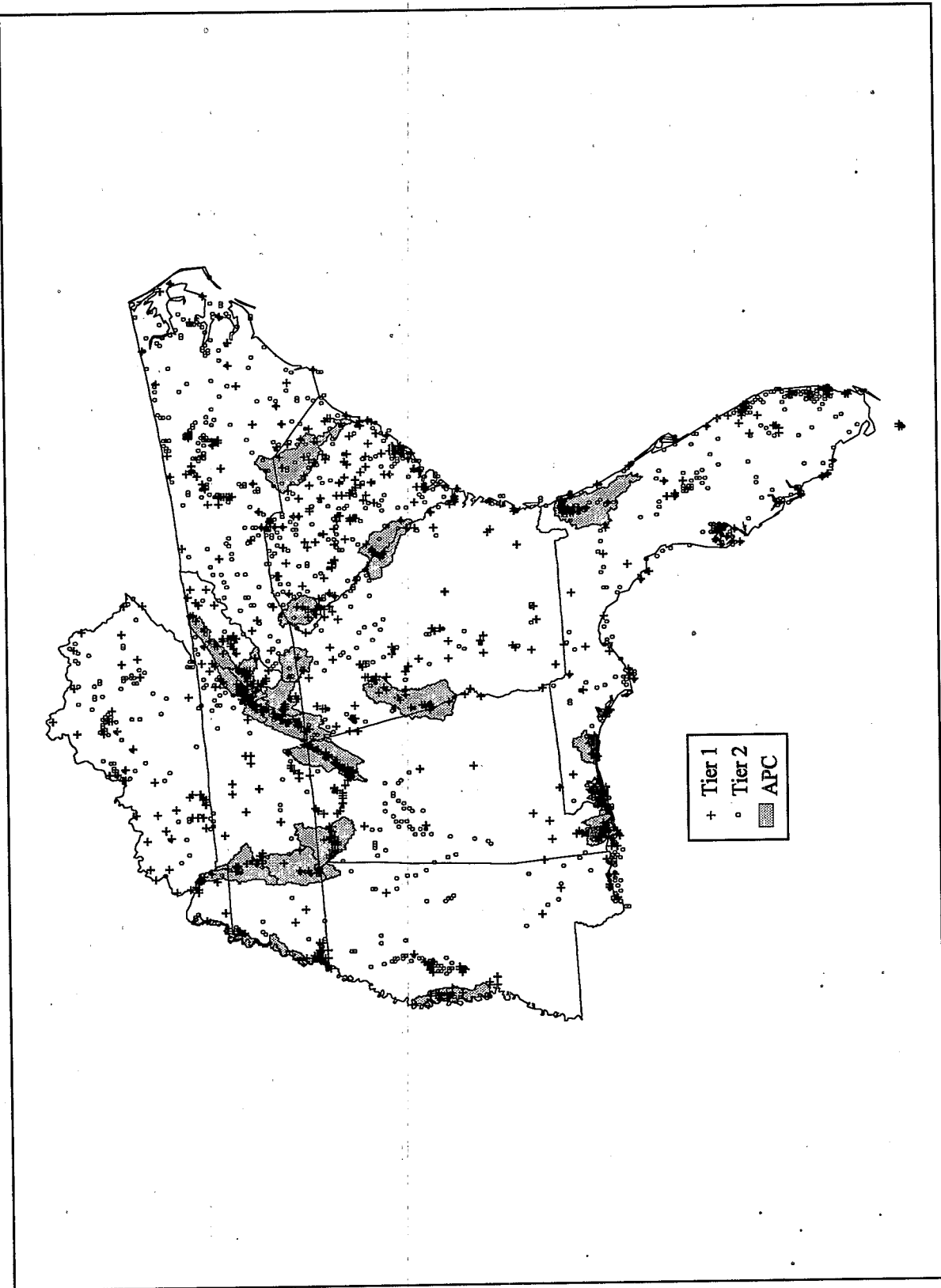

Figure 3-21. Region 4: Location of Sampling Stations Classified as Tier 1 or Tier 2 and Watersheds Containing Areas of Probable Concern for Sediment Contamination (APCs).

Table 3-20. Region 4: Watersheds Containing Areas of Probable Concern for Sediment Contamination

Cataloging Unit Number	Name	State(s)*	Number of Sampling Stations			Percent of Sampling Stations in Tier 1 or Tier 2
			Tier 1	Tier 2	Tier 3	
06010201	Watts Bar Lake	TN	63	7	19	79
06010207	Lower Clinch	TN	61	14	4	95
06030005	Pickwick Lake	TN, AL, (MS)	49	9	11	84
06020001	Middle Tennessee- Chickamauga	GA, TN, (AL)	47	29	18	81
03080103	Lower St. Johns	FL	32	111	45	76
03160205	Mobile Bay	AL	31	43	7	91
06030001	Guntersville Lake	TN, AL, (GA)	25	46	21	77
03130002	Middle Chattahoochee-Lake Harding	GA, (AL)	21	4	2	93
03060106	Middle Savannah	GA, SC	20	11	5	86
03140102	Choctawhatchee Bay	FL	19	23	9	82
06040001	Lower Tennessee-Beech	TN, (MS)	15	6	4	84
06040005	Kentucky Lake	KY, TN	15	14	1	97
08010100	Lower Mississippi-Memphis	AR, MS, KY, MO, TN	14	3	3	85
06020002	Hwassee	GA, NC, TN	13	17	3	91
06010104	Holston	TN	12	2	1	93
03040201	Lower Pee Dee	NC, SC	11	20	3	91
08030209	Deer-Steele	MS, (LA)	11	10	0	100
03060101	Seneca	NC, SC	10	3	3	81
03140107	Perdido Bay	FL, AL	10	24	4	89

*No data were available for states listed in parentheses.

Table 3-21. Region 4: Water Bodies With Sampling Stations Classified as Tier 1 Located in Watersheds Containing APCs

Water Body	# of Tier 1 Stations	Water Body	# of Tier 1 Stations
Tennessee River	80	Cypress Creek	2
St. Johns River	30	Deer River	2
Lookout Creek	29	Long Cane Creek	2
Mobile Bay	29	Seneca River	2
Wilson Lake	27	Shoal Creek	2
Poplar Creek	21	Spring Creek	2
Clinch River	18	Twelvemile Creek	2
Choctawhatchee Bay	17	West Pont Lake	2
Guntersville Lake	17	Beech Creek	1
Poplar Creek, Brushy Fork	17	Big Black Creek	1
Little River	16	Big Sandy Creek	1
Chattahoochee River	14	Chatugue Lake	1
Watts Bar Lake	14	Conecross Creek	1
Mississippi River	12	Coon Creek	1
Horse Creek	10	Elevenmile Creek	1
Black Bayou	9	Golden Creek	1
Holston River	9	Hiwassee Lake	1
Kentucky Lake	9	Jeffries Creek	1
Savannah River	9	Lake Harding	1
Hiwassee River	8	Lake Keowee	1
Perdido Bay	7	Lake Washington	1
Melton Hill Lake	5	Lafayette Creek	1
Cherokee Lake	3	Little Horse Creek	1
Fort Loudoun Lake	3	Mountain Creek	1
Gulf Of Mexico	3	Mud Creek	1
Hartwell Reservoir	3	Nottely Lake	1
Lake Chickamauga	3	Oostanaula Creek	1
Pee Dee River	3	Pottsburg Creek	1
Pickwick Lake	3	Rogers Creek	1
Big Nance Creek	2	Sinking Creek	1
Black Creek	2	Steele Bayou	1
Catfish Creek	2	Sweetwater Creek	1
Crooked Creek	2		

Table 3-22. Region 4: Chemicals Most Often Associated With Tier 1 or Tier 2 Sampling Station Classifications*

	Chemical	# Tier 1 & Tier 2 Stations	# Tier 1 Station	# Tier 2 Station		Chemical	# Tier 1 & Tier 2 Stations	# Tier 1 Station	# Tier 2 Station	
Region 4 Overall	Polychlorinated biphenyls	1034	669	365	Kentucky (continued)	Arsenic	65	3	62	
	Lead	989	--	989		Copper	55	--	55	
	Copper	935	--	935		Polychlorinated biphenyls	50	48	2	
	Mercury	923	235	688		Zinc	43	--	43	
	Nickel	820	--	820		Chlordane	41	3	38	
	DDT	751	157	594		Dieldrin	40	3	37	
	Cadmium	751	--	751		Mercury	35	5	30	
	Arsenic	734	37	697	Mississippi	DDT	99	31	68	
	Chromium	459	26	433		Nickel	66	--	66	
	Zinc	438	--	438		Arsenic	63	1	62	
	Chlordane	374	7	367		Polychlorinated biphenyls	44	15	29	
	Benzo(a)pyrene	289	28	261		Cadmium	33	--	33	
	Pyrene	279	62	217		Chromium	32	--	32	
	Dieldrin	252	9	243		Lead	28	--	28	
	Fluoranthene	207	34	173		Dieldrin	24	--	24	
Alabama	Mercury	125	42	83		North Carolina	Copper	150	--	150
	Arsenic	118	4	114			Mercury	133	30	103
	Polychlorinated biphenyls	114	98	16	Lead		128	--	128	
	Cadmium	103	--	103	South Carolina	Nickel	99	--	99	
	Nickel	97	--	97		Arsenic	75	--	75	
	Copper	94	--	94		Chromium	72	2	70	
	Lead	85	--	85		Cadmium	62	--	62	
	DDT	76	8	68		Polychlorinated biphenyls	60	28	32	
	Zinc	76	--	76		Zinc	45	--	45	
Chromium	69	1	68	DDT	27	1	26			
Florida	Mercury	302	52	250	Tennessee	Lead	198	--	198	
	Polychlorinated biphenyls	293	82	211		DDT	188	48	140	
	Lead	291	--	291		Mercury	144	19	125	
	Copper	283	--	283		Copper	141	--	141	
	DDT	242	48	194		Polychlorinated biphenyls	132	93	39	
	Cadmium	208	--	208		Nickel	131	--	131	
	Benzo(a)pyrene	193	19	174		Cadmium	129	--	129	
	Pyrene	176	30	146		Chromium	63	12	51	
	Arsenic	171	7	164		Arsenic	62	18	44	
Chlordane	169	--	169	Zinc		58	--	58		
Georgia	Polychlorinated biphenyls	111	82	29	Kentucky	Polychlorinated biphenyls	230	223	7	
	Arsenic	62	--	62		Nickel	164	--	164	
	Cadmium	60	--	60		Lead	137	--	137	
	Copper	60	--	60		Mercury	134	75	59	
	Lead	46	--	46		Copper	130	--	130	
	Chlordane	45	4	41		Arsenic	118	4	114	
	Mercury	43	12	31		Cadmium	87	--	87	
	Nickel	38	--	38		Zinc	83	--	83	
	DDT	36	11	25		DDT	57	6	51	
Chromium	33	2	31	Dieldrin	52	3	49			
Kentucky	Nickel	105	--	105						
	Lead	76	--	76						
	Cadmium	69	--	69						

*Stations may be listed for more than one chemical.

EPA Region 5

Illinois, Indiana, Michigan, Minnesota, Ohio, Wisconsin

EPA evaluated 4,290 sampling stations in Region 5 as part of the NSI evaluation. Sediment contamination where associated adverse effects to aquatic life are probable (Tier 1) was found at 642 of these sampling stations, and possible but infrequent (Tier 2) at 2,011 of these sampling stations. For human health, data for 777 sampling stations indicated probable association with adverse effects (Tier 1), and 1,469 sampling stations indicated possible but infrequent adverse effects (Tier 2). Overall, this evaluation resulted in the classification of 1,418 sampling stations (33 percent) as Tier 1, 2,137 (50 percent) as Tier 2, and 735 (17 percent) as Tier 3. (It should be noted that the NSI includes sampling data from the Great Lakes Sediment Inventory that, because of a lack of latitude and longitude data, were not included in the NSI evaluation. Had those data been included in the NSI evaluation, an additional 221 stations would have been categorized as Tier 1, 392 as Tier 2, and 84 as Tier 3.) The NSI sampling stations in Region 5 were located in 1,432 separate river reaches, or 24 percent of all reaches in the Region. Ten percent of all river reaches in Region 5 included at least one Tier 1 station, 10 percent included at least one Tier 2 station but no Tier 1 stations, and 4 percent had only Tier 3 stations (Figure 3-22). Table 3-23 (on the following page) presents a summary of sampling station classification and evaluation of river reaches for each state and for the Region as a whole.

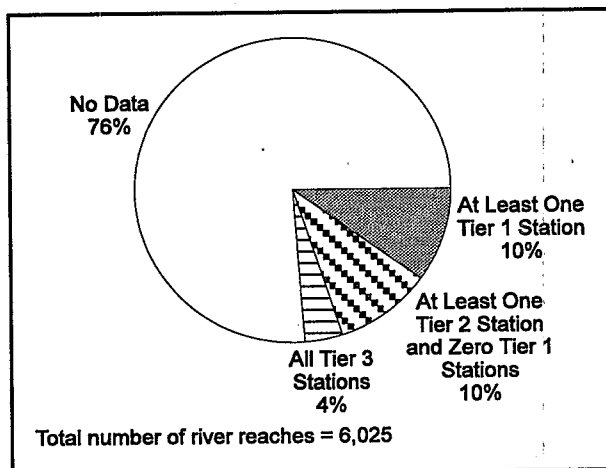

Figure 3-22. Region 5: Percent of River Reaches That Include Tier 1, Tier 2, and Tier 3 Sampling Stations.

This evaluation identified 36 watersheds containing areas of probable concern for sediment contamination (APCs) out of the 278 watersheds (13 percent) in Region 5 (Figure 3-23). In addition, 59 percent of all watersheds in the Region had at least one Tier 1 sampling station but were not categorized as containing APCs, 7 percent had at least one Tier 2 station but no Tier 1 stations, and 3 percent had only Tier 3 stations. Eighteen percent of the watersheds in Region 5 did not include a sampling station. The locations of the watersheds containing APCs and the Tier 1 and Tier 2 sampling stations in Region 5 are illustrated in Figure 3-24.

Within the 36 watersheds in Region 5 identified as containing APCs (Table 3-24), 102 water bodies have at least 1 Tier 1 sampling station; 18 water bodies have 10 or more Tier 1 sampling stations (Table 3-25). The Detroit River, Fox River, Milwaukee River, Mississippi River, Chicago Ship Canal, and several coastal areas of Lake Michigan and Lake Erie appear to have the most significant sediment contamination in Region 5. The water bodies listed on Table 3-25 are not inclusive of all locations containing a Tier 1 sampling station because only water bodies within watersheds containing APCs are listed.

The chemicals most often associated with Tier 1 and Tier 2 sampling station classifications in Region 5 overall and in each state in Region 5 are presented in Table 3-26.

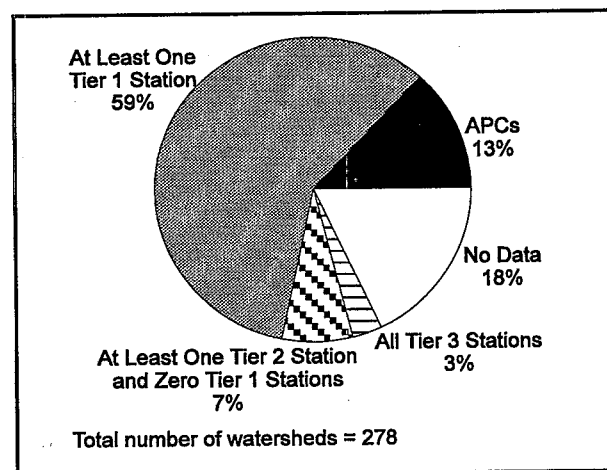

Figure 3-23. Region 5: Watershed Classifications.

Table 3-23. Region 5: Evaluation Results for Sampling Stations and River Reaches by State

State	Station Evaluation						River Reach Evaluation*							
	Tier 1		Tier 2		Tier 3		Number of Stations Not Identified by an RFI ^b or Reach ^b	Reaches w/at Least 1 Station in Tier 1	Reaches w/at Least 1 Station in Tier 2 ^c	Reaches w/all Stations in Tier 3	Total # Reaches w/at Least 1 Station Evaluated	Total Reaches in State	% of all Reaches in State w/at Least 1 Station Evaluated	% of Reaches w/at Least 1 or Tier 2 Station
	No.	%	No.	%	No.	%								
Illinois	428	26	1,075	64	166	10	8	182	255	30	467	920	51	48
Indiana	67	62	23	21	18	17	3	35	8	1	44	559	8	8
Michigan	219	54	144	36	39	10	20	64	41	11	116	1,145	10	9
Minnesota	220	50	65	15	153	35	-	140	34	90	264	1,355	20	13
Ohio	130	13	704	73	136	14	71	56	191	57	304	1,054	29	23
Wisconsin	354	50	126	18	223	32	6	130	47	82	259	1,174	22	15
REGION 5 ^d	1,418	33	2,137	50	735	17	108	594	570	268	1,432	6,025	24	19

*River reaches based on EPA River Reach File 1 (RFI).

^bStations not identified by an RFI reach were located in coastal or open water areas.

^cNo stations in these reaches were included in Tier 1.

^dBecause some reaches occur in more than one state, the total number of reaches in each category for the Region might not equal the sum of reaches in the states.

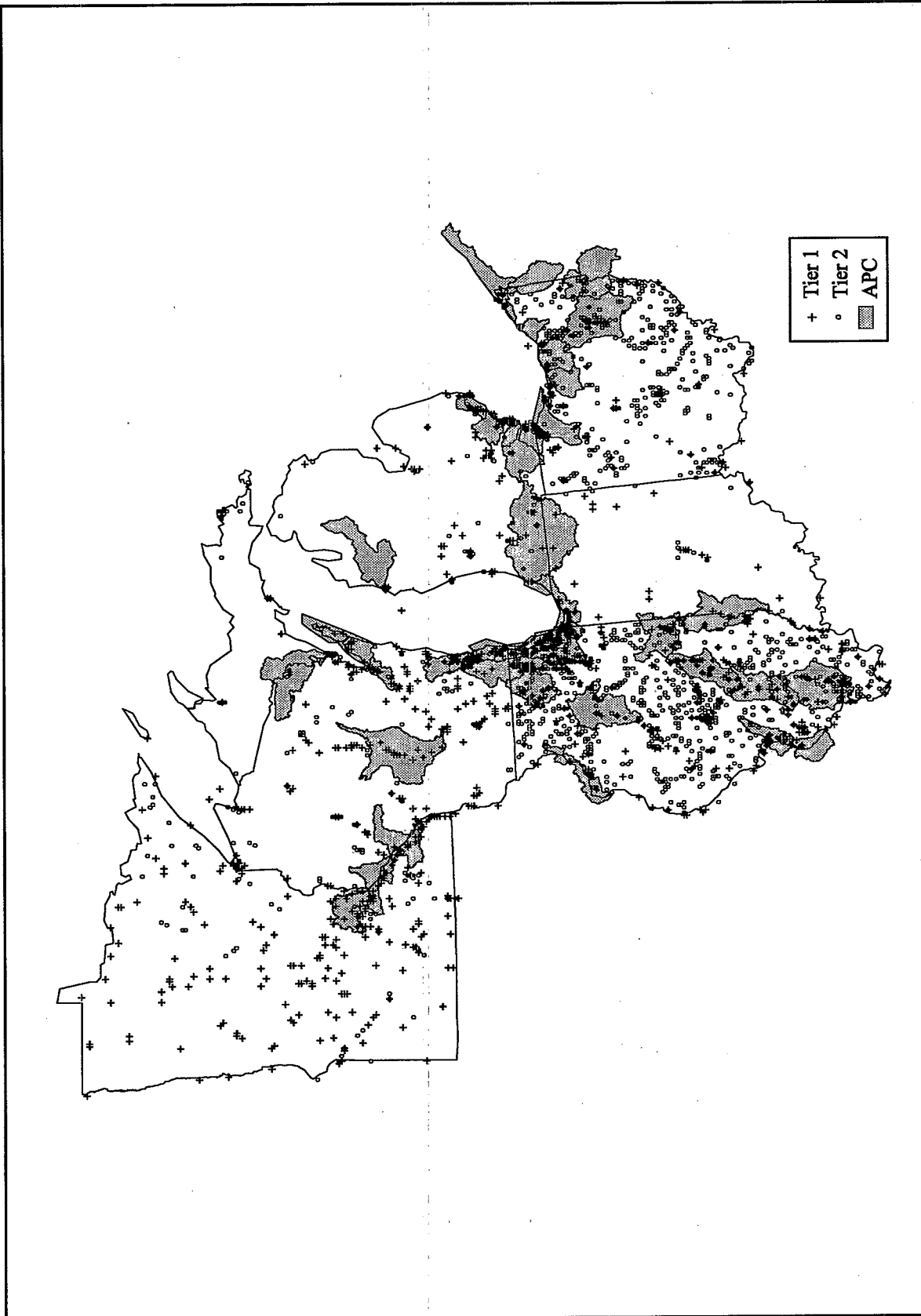

Figure 3-24. Region 5: Location of Sampling Stations Classified as Tier 1 or Tier 2 and Watersheds Containing Areas of Probable Concern for Sediment Contamination (APCs).

Table 3-24. Region 5: Watersheds Containing Areas of Probable Concern for Sediment Contamination

Cataloging Unit Number	Name	State(s)*	Number of Sampling Stations			Percent of Sampling Stations in Tier 1 or Tier 2
			Tier 1	Tier 2	Tier 3	
04090004	Detroit	MI	85	29	1	99
07120003	Chicago	IN, IL	64	36	3	97
07120004	Des Plaines	WI, IL	61	43	6	95
04040003	Milwaukee	WI	60	16	14	84
04030204	Lower Fox	WI	49	2	0	100
04040001	Little Calumet-Galien	IL, IN, (MI)	45	26	18	80
04040002	Pike-Root	WI, IL	34	30	8	89
07140201	Upper Kaskaskia	IL	31	24	0	100
07010206	Twin Cities	WI, MN	26	2	7	80
04110001	Black-Rocky	OH	24	31	4	93
07140106	Big Muddy	IL	23	65	6	94
04120101	Chautauqua-Conneaut	NY, PA, OH	21	86	3	97
07070003	Castle Rock	WI	20	0	2	91
04100002	Raisin	MI, (OH)	18	19	1	97
07140101	Cahokia-Joachim	MO, IL	18	34	4	93
04050001	St. Joseph	IN, MI	17	9	6	81
07040003	Buffalo-Whitewater	WI, MN	17	3	6	77
07080101	Copperas-Duck	IL, IA	17	5	5	81
05120111	Middle Wabash-Busseron	IN, IL	15	17	1	97
07120006	Upper Fox	WI, IL	15	40	5	92
04090002	Lake St. Clair	MI	13	5	1	95
04100001	Ottawa-Stony	OH, MI	13	15	1	97
04100010	Cedar-Portage	MI, OH	13	39	4	93
07040001	Rush-Vermilion	WI, MN	13	1	0	100
07140202	Middle Kaskaskia	IL	13	22	3	92
04030102	Door-Kewaunee	WI	12	5	3	85
04030108	Menominee	MI, WI	12	6	3	86
05030101	Upper Ohio	WV, PA, OH	12	29	12	77
05120109	Vermilion	IL, (IN)	12	16	0	100
04060103	Manistee	MI	11	3	0	100
05030102	Shenango	OH, PA	11	1	3	80
07130001	Lower Illinois-Senachwine Lake	IL	11	10	0	100
04100012	Huron-Vermilion	OH	10	35	0	100
04110003	Ashtabula-Chagrin	OH	10	18	3	90
05040001	Tuscarawas	OH	10	53	15	81
07090006	Kishwaukee	IL, (WI)	10	24	0	100

*No data were available for states listed in parentheses.

Table 3-25. Region 5: Water Bodies With Sampling Stations Classified as Tier 1 Located in Watersheds Containing APCs

Water Body	# of Tier 1 Stations	Water Body	# of Tier 1 Stations
Detroit River	64	Becks Creek	2
Lake Erie, U.S. Shore	60	Castle Rock Flowage	2
Fox River	58	Coldwater River	2
Mississippi River	56	Crab Orchard Creek	2
Milwaukee River	55	Crooked Creek	2
Lake Michigan	45	Hickory Creek	2
Chicago Sanitary Ship Canal	41	Kaskaskia Creek, E. Fork	2
Des Plains River	27	Kaskaskia River, Lake Fork	2
Kaskaskia River	21	Lake Shelbyville	2
Calumet River	19	Little Creek	2
River Raisin	16	Portage River, E. Br.	2
Indiana Harbor	15	Ramsey Creek	2
Wisconsin River	15	Saline River	2
Wabash River	14	Vermilion River	2
Lake St. Clair	13	Barton Lake	1
Little Calumet River	13	Beaucoup Creek	1
River Rouge	13	Big Bureau Creek	1
Menominee River	12	Big Muddy River, M. Fork	1
Du Page River	9	Buffalo Creek	1
Illinois River	9	Burns Ditch	1
Cahokia Canal	8	Clark Lake	1
Manistee Lake	8	Coon River	1
Big Muddy River, Casey Fork	7	Deep River	1
Black River	7	East River	1
Crab Orchard Lake	7	Eliza Creek	1
Du Page River, E. Br.	7	Garvin Brook	1
Du Page River, W. Br.	7	Gilmore Creek	1
Grosse Isle	7	Grosse Isle	1
Lake Minnetonka	7	Hog Creek	1
St. Joseph River	7	Kaskaskia Creek, N. Fork	1
Tuscarawas River	7	Kilbourn Ditch	1
Lake Calumet	6	Killbuck Creek	1
Ashtabula River	5	Lake Creek	1
Cedar Creek	5	Lemonweir River	1
Fox Lake	5	Little Crooked Creek	1
Kishwaukee River, S. Br.	5	Little Roche A Cri Creek	1
Lake Michigan, Green Bay	5	Mill Creek	1
Chicago Ship Canal	4	Ottawa Creek	1
Root River	4	Petenwell Flowage	1
Salt Creek	4	Pigeon River	1
Vermilion River, Salt Fork	4	Piscasaw River	1
Big Muddy River	3	Rend Lake	1
Chicago River, N. Br.	3	Rocky River	1
Huron River	3	Sturgeon Bay	1
Kishwaukee River	3	Sugar Creek	1

Table 3-25. (continued)

Water Body	# of Tier 1 Stations	Water Body	# of Tier 1 Stations
Manistee River	3	Swan Creek	1
Nimishillen Creek	3	Upper Salt Fork Drainage Ditch	1
Ohnathan Creek	3	Vermilion River, M. Fork	1
Paw Paw River	3	W Bureau Creek	1
Vermilion River, N. Fork	3	Wall Town Drainage Ditch	1
W Okaw River	3	Whitewater River	1

Table 3-26. Region 5: Chemicals Most Often Associated With Tier 1 or Tier 2 Sampling Station Classifications*

	Chemical	# Tier 1 & Tier 2 Stations	# Tier 1 Station	# Tier 2 Station		Chemical	# Tier 1 & Tier 2 Stations	# Tier 1 Station	# Tier 2 Station	
Region 5 Overall	Copper	1,625	--	1,625	Michigan (continued)	Nickel	198	--	198	
	Polychlorinated biphenyls	1,460	1,113	347		DDT	182	97	85	
	Lead	1,326	--	1,326		Zinc	170	--	170	
	Dieldrin	1,318	36	1,282		Mercury	140	53	87	
	Nickel	1,260	--	1,260		Pyrene	140	50	90	
	Cadmium	1,203	--	1,203		Cadmium	140	--	140	
	Arsenic	1,019	32	987		Fluoranthene	133	20	113	
	Zinc	915	--	915		Minnesota	Polychlorinated biphenyls	225	216	9
	Mercury	761	197	564			Dieldrin	88	--	88
	Chlordane	723	--	723			Cadmium	66	--	66
	DDT	668	177	491			DDT	30	--	30
	Chromium	414	81	333			Copper	24	--	24
	Heptachlor epoxide	338	--	338			Lead	21	--	21
	Pyrene	300	103	197			Mercury	17	--	17
Fluoranthene	290	59	231	Dioxins	10		10	--		
Illinois	Dieldrin	1019	33	986	Chromium		9	--	9	
	Copper	616	--	616	Aldrin		5	--	5	
	Chlordane	518	--	518	Ohio	Nickel	644	--	644	
	Polychlorinated biphenyls	503	318	185		Copper	577	--	577	
	Lead	464	--	464		Lead	472	--	472	
	Cadmium	460	--	460		Arsenic	459	2	457	
	Arsenic	380	18	362		Cadmium	420	--	420	
	Nickel	342	--	342		Zinc	381	--	381	
	Mercury	330	72	258		Mercury	125	16	109	
DDT	275	36	239	Chromium		123	19	104		
Indiana	Polychlorinated biphenyls	66	59	7		Fluoranthene	108	17	91	
	Arsenic	53	3	50	Polychlorinated biphenyls	97	65	32		
	Dieldrin	51	3	48	Wisconsin	Polychlorinated biphenyls	319	304	15	
	Chlordane	48	--	48		Copper	159	--	159	
	Heptachlor epoxide	42	--	42		Mercury	127	42	85	
	Copper	36	--	36		Lead	120	--	120	
	Lead	36	--	36		DDT	100	15	85	
	BHC	33	7	26		Cadmium	88	--	88	
	DDT	33	6	27		Dieldrin	76	--	76	
Cadmium	29	--	29	Pyrene		62	21	41		
Michigan	Polychlorinated biphenyls	250	151	99		Zinc	60	--	60	
	Copper	213	--	213	Nickel	54	--	54		
	Lead	213	--	213						

*Stations may be listed for more than one chemical.

EPA Region 6

Arkansas, Louisiana, New Mexico, Oklahoma, Texas

EPA evaluated 1,616 sampling stations in Region 6 as part of the NSI evaluation. Sediment contamination where associated adverse effects to aquatic life are probable (Tier 1) was found at 222 of these sampling stations, and possible but infrequent (Tier 2) at 852 of these sampling stations. For human health, data for 189 sampling stations indicated probable association with adverse effects (Tier 1), and 421 sampling stations indicated possible but infrequent adverse effects (Tier 2). Overall, this evaluation resulted in the classification of 382 sampling stations (24 percent) as Tier 1, 837 (52 percent) as Tier 2, and 397 (24 percent) as Tier 3. The NSI sampling stations in Region 6 were located in 799 separate river reaches, or 11 percent of all reaches in the Region. Three percent of all river reaches in Region 6 included at least one Tier 1 station, 5 percent included at least one Tier 2 station but no Tier 1 stations, and 3 percent had only Tier 3 stations (Figure 3-25). Table 3-27 (on the following page) presents a summary of sampling station classification and evaluation of river reaches for each state and for the Region as a whole.

This evaluation identified 8 watersheds containing areas of probable concern for sediment contamination

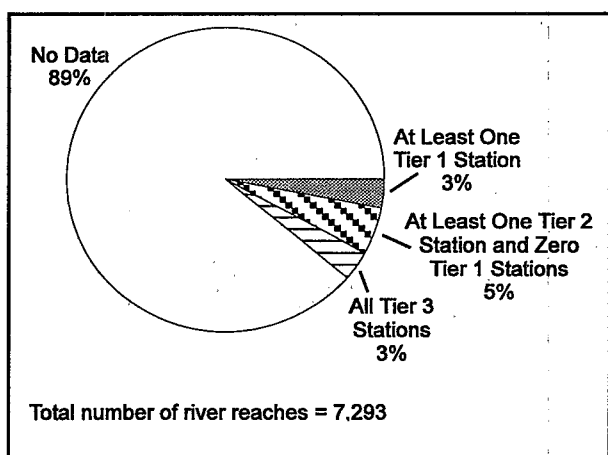

Figure 3-25. Region 6: Percent of River Reaches That Include Tier 1, Tier 2, and Tier 3 Sampling Stations.

(APCs) out of the 403 watersheds (2 percent) in Region 6 (Figure 3-26). In addition, 36 percent of all watersheds in the Region had at least one Tier 1 sampling station but were not identified as containing APCs, 21 percent had at least one Tier 2 station but no Tier 1 stations, and 10 percent had only Tier 3 stations. Thirty-one percent of the watersheds in Region 6 did not include a sampling station. The locations of the watersheds containing APCs and the Tier 1 and Tier 2 sampling stations in Region 6 are illustrated in Figure 3-27.

Within the 8 watersheds in Region 6 identified as containing APCs (Table 3-28), 17 water bodies have at least 1 Tier 1 sampling station; 4 water bodies have 10 or more Tier 1 sampling stations (Table 3-29). The Calcasieu River and Mississippi River in Louisiana appear to have some of the most significant sediment contamination in Region 6. The water bodies listed on Table 3-29 are not inclusive of all locations containing a Tier 1 sampling station because only water bodies within watersheds containing APCs are listed.

The chemicals most often associated with Tier 1 or Tier 2 sampling station classifications in Region 6 overall and in each state in Region 6 are presented in Table 3-30.

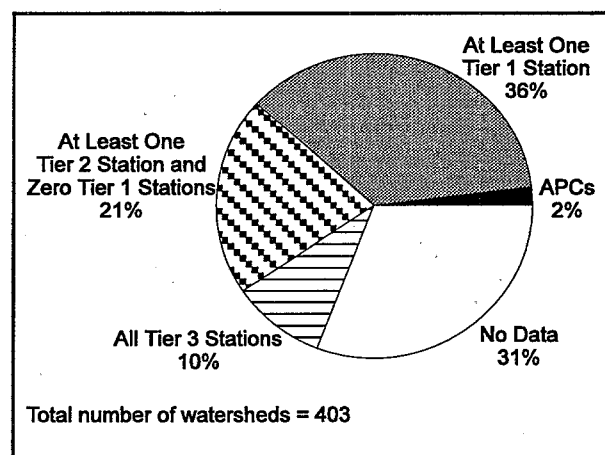

Figure 3-26. Region 6: Watershed Classifications.

Table 3-27. Region 6: Evaluation Results for Sampling Stations and River Reaches by State

State	Station Evaluation						River Reach Evaluation ^a							
	Tier 1		Tier 2		Tier 3		Number of Stations Not Identified by an RFI Reach ^b	Reaches w/at Least 1 Station in Tier 1	Reaches w/at Least 1 Station in Tier 2 ^c	Reaches w/all Stations in Tier 3	Total # Reaches w/at Least 1 Station Evaluated	Total Reaches in State	% of all Reaches in State w/at Least 1 Station Evaluated	% of Reaches w/at Least 1 or Tier 2 Station
	No.	%	No.	%	No.	%								
Arkansas	18	17	39	36	50	47	-	17	31	40	88	855	10	6
Louisiana	111	24	270	59	79	17	57	45	68	29	142	840	17	13
New Mexico	4	4	40	40	57	56	-	4	28	28	60	919	7	3
Oklahoma	122	43	95	33	69	24	-	97	59	41	197	1,308	15	12
Texas	127	19	393	59	142	22	67	104	160	56	320	3,588	9	7
REGION 6 ^d	382	24	837	52	397	24	124	266	341	192	799	7,293	11	8

^aRiver reaches based on EPA River Reach File 1 (RFI).

^bStations not identified by an RFI reach were located in coastal or open water areas.

^cNo stations in these reaches were included in Tier 1.

^dBecause some reaches occur in more than one state, the total number of reaches in each category for the Region might not equal the sum of reaches in the states.

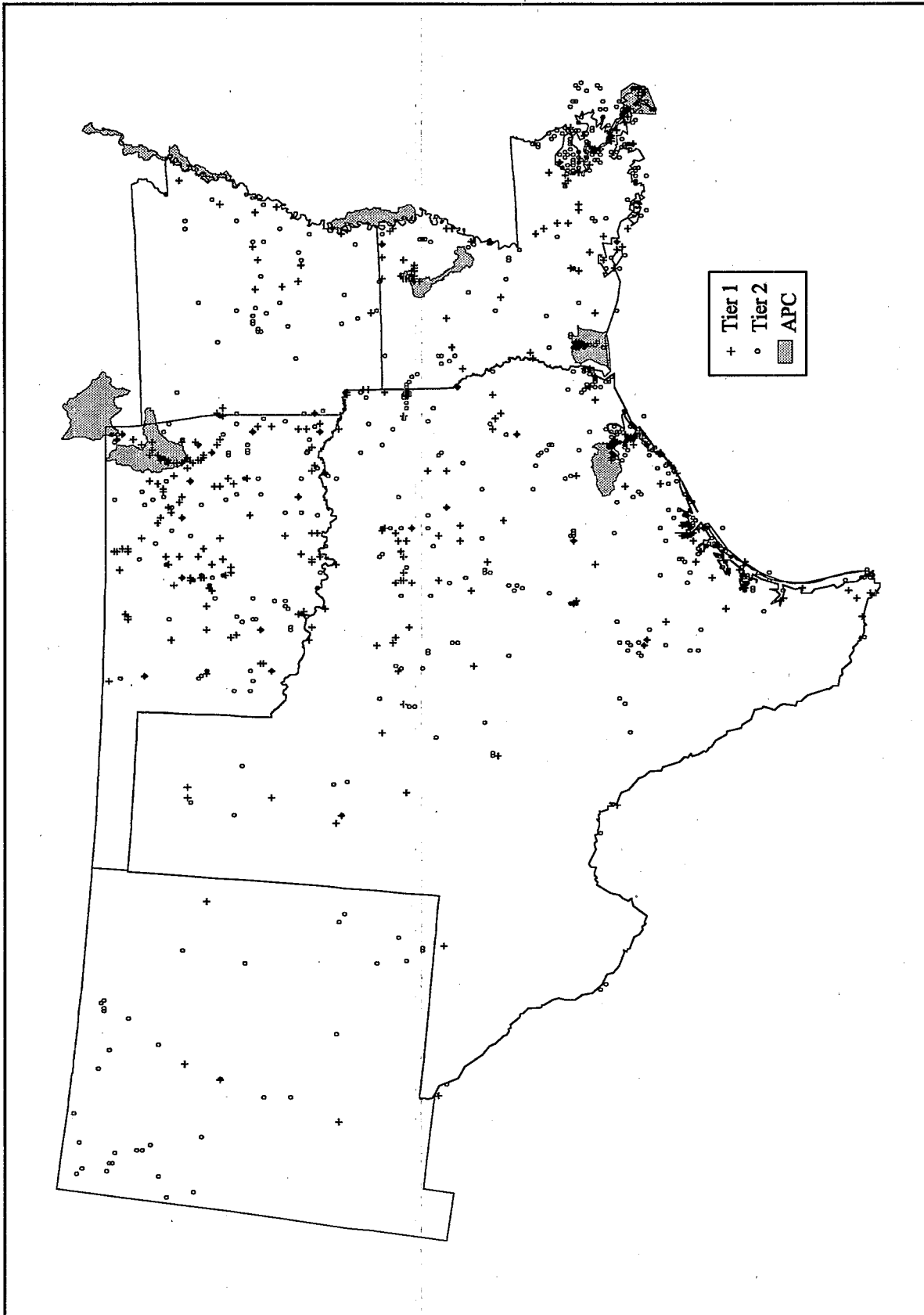

Figure 3-27. Region 6: Location of Sampling Stations Classified as Tier 1 or Tier 2 and Watersheds Containing Areas of Probable Concern for Sediment Contamination (APCs).

Table 3-28. Region 6: Watersheds Containing Areas of Probable Concern for Sediment Contamination

Cataloging Unit Number	Name	State(s) ^a	Number of Sampling Stations			Percent of Sampling Stations in Tier 1 or Tier 2
			Tier 1	Tier 2	Tier 3	
08080206	Lower Cakaseu	LA	26	52	22	78
08090100	Lower Mississippi-New Orleans	LA	16	34	1	98
08010100	Lower Mississippi-Memphis	AR, MS, KY, MO, TN	14	3	3	85
11070209	Lower Neosho	OK, (AR)	13	3	4	80
08040207	Lower Ouachita	LA	12	0	0	100
08030209	Deer-Steele	MS, (LA)	11	10	0	100
11070207	Spring	OK, MO, KS	10	25	6	85
12040104	Buffalo-San Jacinto	TX	10	23	3	92

^aNo data were available for states listed in parentheses.

Table 3-29. Region 6: Water Bodies With Sampling Stations Classified as Tier 1 Located in Watersheds Containing APCs

Water Body	# of Tier 1 Stations	Water Body	# of Tier 1 Stations
Cakaseu River	15	Neosho River	2
Mississippi River	15	Pryor Creek	2
Bayou D'Inde	11	Greens Bayou	1
Bayou De Siard	11	Lake Eucha	1
Buffalo Bayou	5	Mississippi River, Grand Pass	1
Fort Gibson Lake	4	Mississippi River, Pass Loutre	1
Lake Hudson	3	Ouachita River	1
Busch Island	2	Spavinaw Lake	1
Galveston Bay	2		

Table 3-30. Region 6: Chemicals Most Often Associated With Tier 1 or Tier 2 Sampling Station Classifications^a

	Chemical	# Tier 1 & Tier 2 Stations	# Tier 1 Station	# Tier 2 Station		Chemical	# Tier 1 & Tier 2 Stations	# Tier 1 Station	# Tier 2 Station
Region 6 Overall	Nickel	460	--	460	Louisiana (continued)	Dibenzo(a,h)anthracene	59	1	58
	Polychlorinated biphenyls	434	216	218		Lead	57	--	57
	Arsenic	429	3	426	New Mexico	Copper	24	--	24
	Copper	350	--	350		Cadmium	23	--	23
	DDT	327	70	257		Arsenic	17	--	17
	Cadmium	325	--	325		Nickel	12	--	12
	Lead	297	--	297		Lead	8	--	8
	Chromium	290	9	281		Zinc	6	--	6
	Mercury	235	47	188		Mercury	5	3	2
	Chlordane	189	4	185		Chromium	4	--	4
	Silver	144	32	112		Polychlorinated biphenyls	2	2	--
	Zinc	133	--	133		Chlordane	2	--	2
	Dieldrin	132	10	122	Oklahoma	Polychlorinated biphenyls	135	118	17
	BHC	123	16	107		Arsenic	78	1	77
	Dibenzo(a,h)anthracene	122	2	120		Chlordane	73	3	70
				Cadmium		60	--	60	
				DDT		58	7	51	
Arkansas	Arsenic	25	--	25	Lead	43	--	43	
	DDT	23	6	17	Dieldrin	35	1	34	
	Mercury	15	3	12	Copper	27	--	27	
	Polychlorinated biphenyls	14	7	7	Mercury	26	3	23	
	Lead	13	--	13	Toxaphene	20	--	20	
	Dieldrin	7	--	7	Texas	Nickel	259	--	259
	Dioxins	6	6	--		Copper	185	--	185
	Chlordane	6	--	6		Cadmium	182	--	182
	Cadmium	4	--	4		Lead	176	--	176
Copper	3	--	3	Arsenic		168	1	167	
Louisiana	Nickel	178	--	178	Polychlorinated biphenyls	164	45	119	
	Arsenic	141	1	140	Chromium	152	6	146	
	Chromium	132	3	129	DDT	135	31	104	
	Polychlorinated biphenyls	119	44	75	Silver	135	30	105	
	Copper	111	--	111	Mercury	118	17	101	
	DDT	110	26	84					
	SEM (est) ^b	75	--	75					
	Mercury	71	21	50					

^aStations may be listed for more than one chemical.

^bSimultaneously extracted metals.

EPA Region 7

Iowa, Kansas, Missouri, Nebraska

EPA evaluated 1,011 sampling stations in Region 7 as part of the NSI evaluation. Sediment contamination where associated adverse effects to aquatic life are probable (Tier 1) was found at 32 of these sampling stations, and possible but infrequent (Tier 2) at 242 of these sampling stations. For human health, data for 299 sampling stations indicated probable association with adverse effects (Tier 1), and 230 sampling stations indicated possible but infrequent adverse effects (Tier 2). Overall, this evaluation resulted in the classification of 330 sampling stations (33 percent) as Tier 1, 393 (39 percent) as Tier 2, and 288 (28 percent) as Tier 3. The NSI sampling stations in Region 7 were located in 516 separate river reaches, or 11 percent of all reaches in the Region. Five percent of all river reaches in Region 7 included at least one Tier 1 station, 4 percent included at least one Tier 2 station but no Tier 1 stations, and 2 percent had only Tier 3 stations (Figure 3-28). Table 3-31 (on the following page) presents a summary of sampling station classification and evaluation of river reaches for each state and for the Region as a whole.

This evaluation identified 5 watersheds containing areas of probable concern for sediment contamination

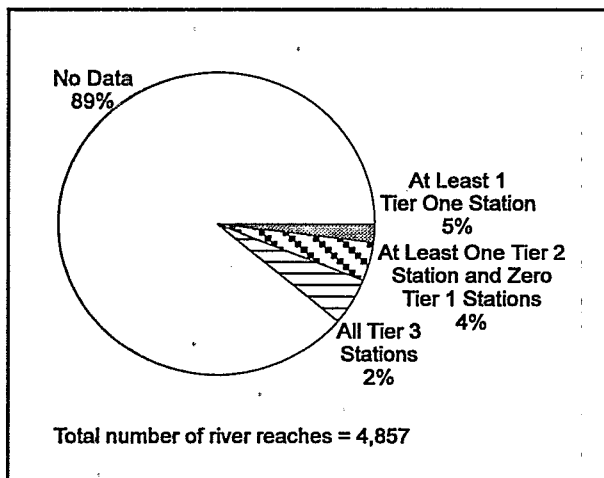

Figure 3-28. Region 7: Percent of River Reaches That Include Tier 1, Tier 2, and Tier 3 Sampling Stations.

(APCs) out of the 239 watersheds (2 percent) in Region 7 (Figure 3-29). In addition, 49 percent of all watersheds in the Region had at least one Tier 1 sampling station but were not identified as containing APCs, 16 percent had at least one Tier 2 station but no Tier 1 stations, and 5 percent had only Tier 3 stations. Twenty-eight percent of the watersheds in Region 7 did not include a sampling station. The locations of the watersheds containing APCs and the Tier 1 and Tier 2 sampling stations in Region 7 are illustrated in Figure 3-30.

Within the 5 watersheds in Region 7 identified as containing APCs (Table 3-32), 12 water bodies have at least 1 Tier 1 sampling station; 1 water body has 10 or more Tier 1 sampling stations (Table 3-33). The water bodies listed on Table 3-33 are not inclusive of all locations containing a Tier 1 sampling station because only water bodies within watersheds containing APCs are listed.

The chemicals most often associated with Tier 1 or Tier 2 sampling station classifications in Region 7 overall and in each state in Region 7 are presented in Table 3-34.

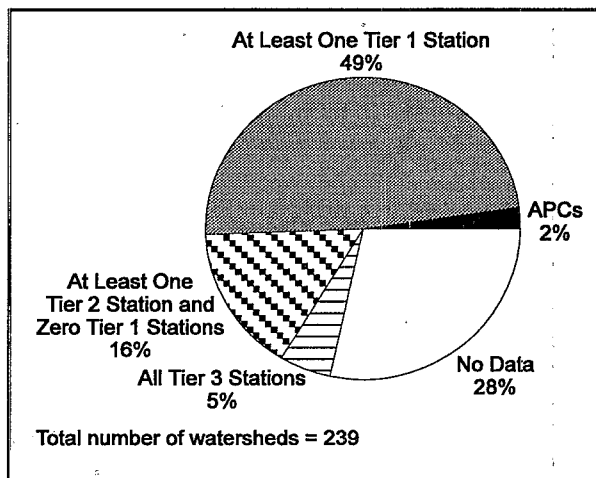

Figure 3-29. Region 7: Watershed Classifications.

Table 3-31. Region 7: Evaluation Results for Sampling Stations and River Reaches by State

State	Station Evaluation						River Reach Evaluation ^a							
	Tier 1		Tier 2		Tier 3		Number of Stations Not Identified by an RFI Reach ^b	Reaches w/at Least 1 Station in Tier 1	Reaches w/at Least 1 Station in Tier 2 ^c	Reaches w/all Stations in Tier 3	Total # Reaches w/at Least 1 Station Evaluated	% of all Reaches in State w/at Least 1 Station Evaluated	% of Reaches w/at Least 1 or Tier 2 Station	
	No.	%	No.	%	No.	%								
Iowa	75	33	104	46	49	21	-	61	50	19	130	1,198	11	9
Kansas	76	38	98	48	29	14	-	64	48	13	125	1,184	11	9
Missouri	124	38	98	30	105	32	-	76	32	18	126	1,364	9	8
Nebraska	55	22	93	37	105	41	-	45	62	39	146	1,265	12	8
REGION 7 ^d	330	33	393	39	288	28	-	246	182	88	516	4,857	11	9

^aRiver reaches based on EPA River Reach File 1 (RFI).

^bStations not identified by an RFI reach were located in coastal or open water areas.

^cNo stations in these reaches were included in Tier 1.

^dBecause some reaches occur in more than one state, the total number of reaches in each category for the Region might not equal the sum of reaches in the states.

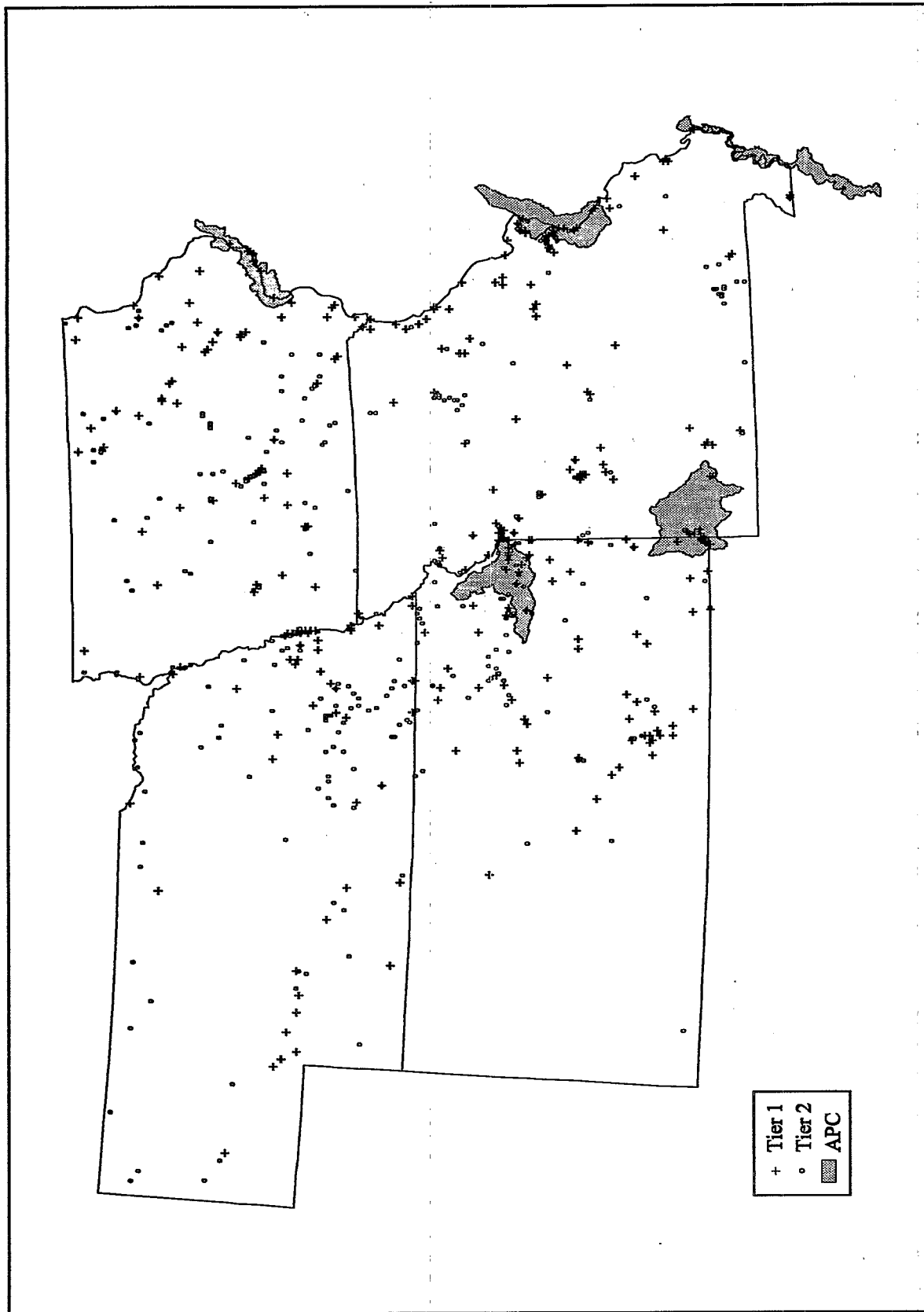

Figure 3-30. Region 7: Locations of Sampling Stations Classified as Tier 1 or Tier 2 and Watersheds Containing Areas of Probable Concern for Sediment Contamination (APCs).

Table 3-32. Region 7: Watersheds Containing Areas of Probable Concern for Sediment Contamination

Cataloging Unit Number	Name	State(s)	Number of Sampling Stations			Percent of Sampling Stations in Tier 1 or Tier 2
			Tier 1	Tier 2	Tier 3	
07140101	Cahokia-Joachim	MO, IL	18	34	4	93
07080101	Copperas-Duck	IL, IA	17	5	5	81
08010100	Lower Mississippi-Memphis	AR, MS, KY, MO, TN	14	3	3	85
10270104	Lower Kansas	MO, KS	12	15	2	93
11070207	Spring	OK, MO, KS	10	25	6	85

Table 3-33. Region 7: Water Bodies With Sampling Stations Classified as Tier 1 Located in Watersheds Containing APCs

Water Body	# of Tier 1 Stations	Water Body	# of Tier 1 Stations
Mississippi River	17	Duck Creek	1
Kansas River	7	Joachim Creek	1
Spring River	5	Kill Creek	1
Center Creek	3	Stranger Creek	1
Cedar Creek	2	Turkey Creek	1
Cow Creek	1	Wakarusa River	1

Table 3-34. Region 7: Chemicals Most Often Associated With Tier 1 or Tier 2 Sampling Station Classifications*

	Chemical	# Tier 1 & Tier 2 Stations	# Tier 1 Station	# Tier 2 Station		Chemical	# Tier 1 & Tier 2 Stations	# Tier 1 Station	# Tier 2 Station
Region 7 Overall	Dieldrin	336	2	334	Kansas (continued)	Arsenic	52	--	52
	Chlordane	329	--	329		Nickel	49	--	49
	Polychlorinated biphenyls	305	291	14		Cadmium	36	--	36
	Arsenic	171	--	171		Lead	34	--	34
	Heptachlor epoxide	138	--	138		Chromium	27	1	26
	Nickel	121	--	121		Zinc	23	--	23
	Cadmium	115	--	115		Copper	20	--	20
	Lead	84	--	84	Missouri	Chlordane	119	--	119
	Copper	74	--	74		Polychlorinated biphenyls	116	102	14
	Chromium	50	5	45		Dieldrin	76	--	76
	Dioxins	44	42	2		Heptachlor epoxide	53	--	53
	Zinc	43	--	43		Arsenic	43	--	43
	Bis(2-ethylhexyl)phthalat	37	9	28		Cadmium	36	--	36
	DDT	33	--	33		Lead	33	--	33
	Aldrin	31	--	31		Dioxins	31	29	2
				Nickel		29	--	29	
				Copper		27	--	27	
Iowa	Dieldrin	126	2	124	Nebraska	Dieldrin	72	--	72
	Chlordane	91	--	91		Chlordane	52	--	52
	Polychlorinated biphenyls	71	71	--		Polychlorinated biphenyls	50	50	--
	Heptachlor epoxide	54	--	54		Arsenic	42	--	42
	Arsenic	34	--	34		Cadmium	29	--	29
	Copper	17	--	17		Nickel	29	--	29
	Cadmium	14	--	14		Chromium	17	2	15
	Nickel	14	--	14		Aldrin	13	--	13
	DDT	12	--	12		Heptachlor epoxide	12	--	12
Lead	10	--	10	Bis(2-ethylhexyl)phthalat	10	4	6		
Kansas	Polychlorinated biphenyls	68	68	--					
	Chlordane	67	--	67					
	Dieldrin	62	--	62					

*Stations may be listed for more than one chemical.

EPA Region 8

Colorado, Montana, North Dakota, South Dakota, Utah, Wyoming

EPA evaluated 535 sampling stations in Region 8 as part of the NSI evaluation. Sediment contamination where associated adverse effects to aquatic life are probable (Tier 1) was found at 39 of these sampling stations, and possible but infrequent (Tier 2) at 325 of these sampling stations. For human health, data for 29 sampling stations indicated probable association with adverse effects (Tier 1), and 19 sampling stations indicated possible but infrequent adverse effects (Tier 2). Overall, this evaluation resulted in the classification of 68 sampling stations (13 percent) as Tier 1, 327 (61 percent) as Tier 2, and 140 (26 percent) as Tier 3. The NSI sampling stations in Region 8 were located in 305 separate river reaches, or 2 percent of all reaches in the Region. Less than 1 percent of all river reaches evaluated in Region 8 included at least one Tier 1 station, 1 percent included at least one Tier 2 station but no Tier 1 stations, and less than 1 percent had only Tier 3 stations (Figure 3-31). Table 3-35 (on the following page) presents a summary of sampling station classification and evalua-

tion of river reaches for each state and for the Region as a whole.

None of the 385 watersheds in Region 8 were identified as watersheds containing areas of probable concern for sediment contamination. Fourteen percent of all watersheds in the Region had at least one Tier 1 sampling station, 12 percent had at least one Tier 2 station but no Tier 1 stations, and 9 percent had only Tier 3 stations (Figure 3-32). Sixty-five percent of the watersheds in Region 8 did not include a sampling station. The locations of the Tier 1 and Tier 2 sampling stations in Region 8 are illustrated in Figure 3-33.

Lack of multiple sampling site data did not allow identification of any watersheds in Region 8 as containing APCs. Therefore, specific water bodies with Tier 1 sampling stations are not listed in a separate table, as for other Regional summaries.

The chemicals most often associated with Tier 1 or Tier 2 sampling station classifications in Region 8 overall and in each state in Region 8 are presented in Table 3-36.

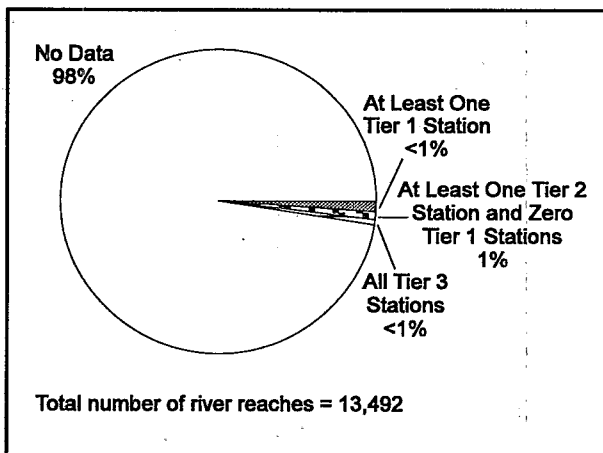

Figure 3-31. Region 8: Percent of River Reaches That Include Tier 1, Tier 2, and Tier 3 Sampling Stations.

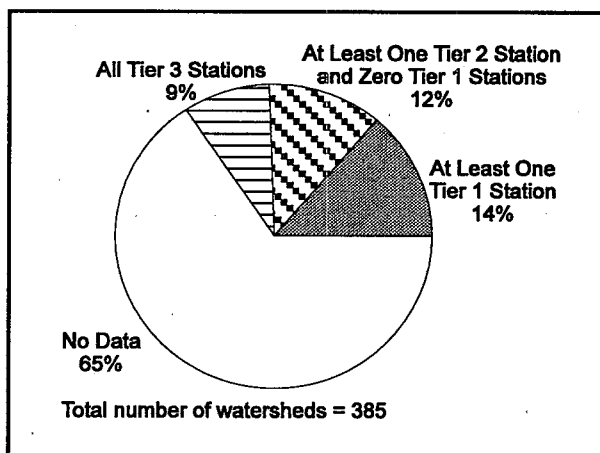

Figure 3-32. Region 8: Watershed Classifications.

Table 3-35. Region 8: Evaluation Results of NSI Sampling Stations and River Reaches by State

State	Station Evaluation						River Reach Evaluation ^a							
	Tier 1		Tier 2		Tier 3		Number of Stations Not Identified by an RFI Reach ^b	Reaches w/at Least 1 Station in Tier 1	Reaches w/at Least 1 Station in Tier 2 ^c	Reaches w/all Stations in Tier 3	Total # Reaches w/at Least 1 Station Evaluated	Total Reaches in State	% of all Reaches in State w/at Least 1 Station Evaluated	% of Reaches w/at Least 1 or Tier 2 Station
	No.	%	No.	%	No.	%								
Colorado	11	6	140	69	51	25	-	8	73	34	115	2,178	5	4
Montana	9	24	18	47	11	29	-	9	10	8	27	5,490	1	<1
North Dakota	24	15	112	70	25	15	-	22	36	9	67	992	7	6
South Dakota	13	30	21	49	9	21	-	11	6	7	24	1,611	2	1
Utah	7	15	24	51	16	34	-	7	16	10	33	1,034	3	2
Wyoming	4	9	12	27	28	64	-	4	12	25	41	2,421	2	1
REGION 8 ^d	68	13	327	61	140	26	-	61	153	91	305	13,492	2	2

^aRiver reaches based on EPA River Reach File 1 (RF1).

^bStations not identified by an RFI reach were located in coastal or open water areas.

^cNo stations in these reaches were included in Tier 1.

^dBecause some reaches occur in more than one state, the total number of reaches in each category for the Region might not equal the sum of reaches in the states.

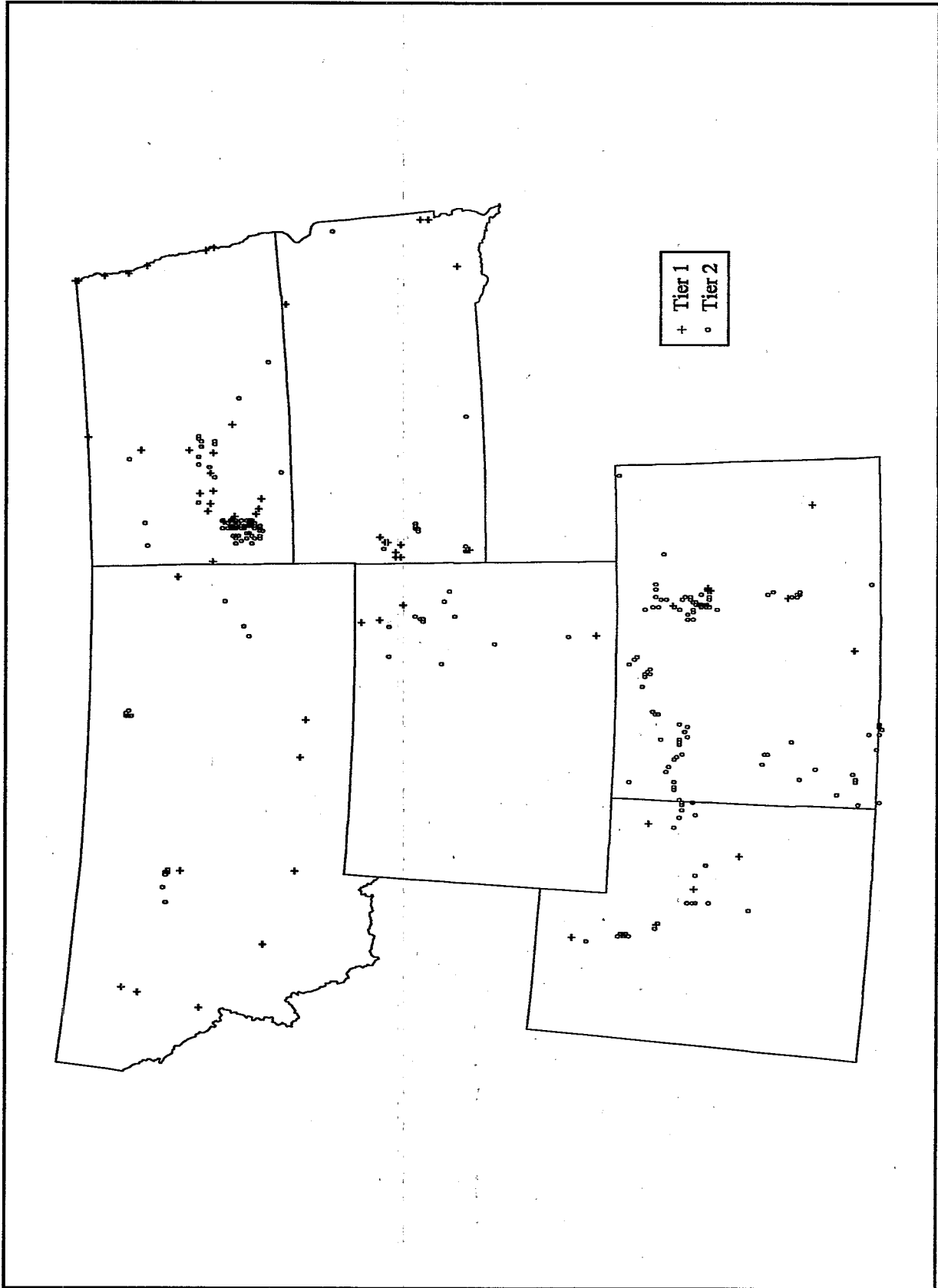

Figure 3-33. Region 8: Locations of Sampling Stations Classified as Tier 1 or Tier 2.

Table 3-36. Region 8: Chemicals Most Often Associated with Tier 1 or Tier 2 Sampling Station Classifications*

	Chemical	# Tier 1 & Tier 2 Stations	# Tier 1 Station	# Tier 2 Station		Chemical	# Tier 1 & Tier 2 Stations	# Tier 1 Station	# Tier 2 Station
Region 8 Overall	Copper	195	--	195	North Dakota (continued)	Chromium	34	--	34
	Nickel	192	--	192		Arsenic	33	12	21
	Cadmium	169	--	169		Cadmium	16	--	16
	Arsenic	155	22	133		Polychlorinated biphenyls	10	10	--
	Lead	74	--	74		Mercury	6	2	4
	Zinc	56	--	56		Dieldrin	4	--	4
	Chromium	53	1	52		Aldrin	2	--	2
	Polychlorinated biphenyls	40	29	11		Bis(2-ethylhexyl)phthalat	2	--	2
	Mercury	35	12	23		Lead	2	--	2
	Dieldrin	20	--	20		South Dakota	Arsenic	23	7
	Aldrin	12	--	12	Lead		16	--	16
	Toxaphene	12	--	12	Nickel		15	--	15
	Silver	11	1	10	Cadmium		9	--	9
	Bis(2-ethylhexyl)phthalat	10	4	6	Copper		9	--	9
	Chlordane	9	--	9	Zinc		6	--	6
					Bis(2-ethylhexyl)phthalat		3	2	1
	Colorado	Cadmium	109	--	109	Utah	Mercury	3	2
Copper		71	--	71	Chromium		3	1	2
Arsenic		59	--	59	Benzo(a)pyrene		2	--	2
Nickel		53	--	53	Cadmium		21	--	21
Lead		50	--	50	Arsenic	14	--	14	
Zinc		43	--	43	Polychlorinated biphenyls	11	4	7	
Mercury		18	6	12	Chlordane	8	--	8	
Chromium		10	--	10	Copper	8	--	8	
Polychlorinated biphenyls		7	4	3	Mercury	7	2	5	
Dieldrin		5	--	5	Wyoming	Lead	6	--	6
Montana	Arsenic	18	--	18		Dieldrin	5	--	5
	Copper	12	--	12		Silver	5	--	5
	Nickel	12	--	12		Zinc	5	--	5
	Polychlorinated biphenyls	9	9	--		Cadmium	11	--	11
	Chromium	6	--	6		Arsenic	8	3	5
	Dieldrin	5	--	5		Polychlorinated biphenyls	2	1	1
	Aldrin	4	--	4	Copper	2	--	2	
	Toxaphene	4	--	4	Bis(2-ethylhexyl)phthalat	1	--	1	
	Cadmium	3	--	3	Mercury	1	--	1	
	Dioxins	2	2	--	North Dakota	Nickel	1	--	1
North Dakota	Nickel	110	--	110		Copper	1	--	1
	Copper	93	--	93		Silver	1	--	1

*Stations may be listed for more than one chemical.

EPA Region 9

Arizona, California, Hawaii, Nevada

EPA evaluated 1,699 sampling stations in Region 9 as part of the NSI evaluation. Sediment contamination where associated adverse effects to aquatic life are probable (Tier 1) was found at 433 of these sampling stations, and possible but infrequent (Tier 2) at 894 of these sampling stations. For human health, data for 40 sampling stations indicated probable association with adverse effects (Tier 1), and 765 sampling stations indicated possible but infrequent adverse effects (Tier 2). Overall, this evaluation resulted in the classification of 468 sampling stations (28 percent) as Tier 1, 942 (55 percent) as Tier 2, and 289 (17 percent) as Tier 3. The NSI sampling stations in Region 9 were located in 254 separate river reaches, or 6 percent of all reaches in the Region. Three percent of all river reaches in Region 9 included at least one Tier 1 station, 2 percent included at least one Tier 2 station but no Tier 1 stations, and 1 percent had only Tier 3 stations (Figure 3-34). Table 3-37 (on the following page) presents a summary of sampling station classification and evaluation of river reaches for each state and for the Region as a whole.

This evaluation identified 10 watersheds containing areas of probable concern for sediment contamination

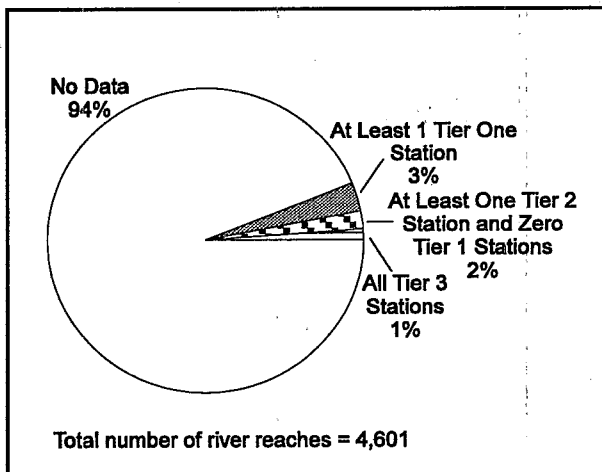

Figure 3-34. Region 9: Percent of River Reaches That Include Tier 1, Tier 2, and Tier 3 Sampling Stations.

(APCs) out of the 279 watersheds (4 percent) in Region 9 (Figure 3-35). In addition, 22 percent of all watersheds in the Region had at least one Tier 1 sampling station but were not classified as containing APCs, 10 percent had at least one Tier 2 station but no Tier 1 stations, and 5 percent had only Tier 3 stations. Fifty-nine percent of the watersheds in Region 9 did not include a sampling station. The locations of the watersheds containing APCs and the Tier 1 and Tier 2 sampling stations in Region 9 are illustrated in Figure 3-36.

Within the 10 watersheds in Region 9 identified as containing APCs (Table 3-38), 19 water bodies have at least 1 Tier 1 sampling station; 7 water bodies have 10 or more Tier 1 sampling stations (Table 3-39). San Diego Bay, San Francisco Bay, and offshore areas around San Diego and Los Angeles appear to have the most significant sediment contamination in Region 9. The water bodies listed on Table 3-39 are not inclusive of all locations containing a Tier 1 sampling station because only water bodies within watersheds containing APCs are listed.

The chemicals most often associated with Tier 1 or Tier 2 sampling station classifications in Region 9 overall and in each state in Region 9 are presented in Table 3-40.

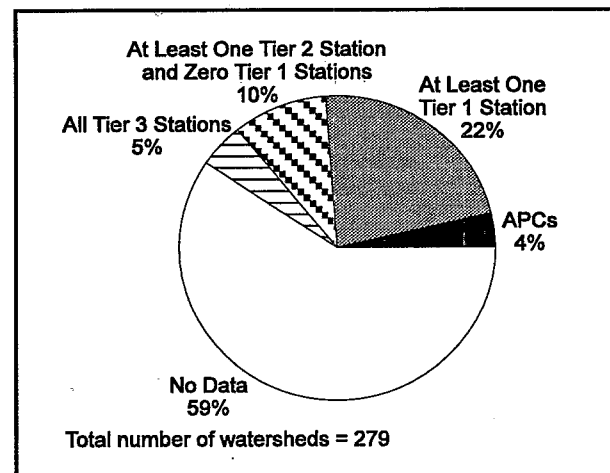

Figure 3-35. Region 9: Watershed Classifications.

Table 3-37. Region 9: Evaluation Results for NSI Sampling Stations and River Reaches by State

State	Station Evaluation						River Reach Evaluation ^a							
	Tier 1		Tier 2		Tier 3		Number of Stations Not Identified by an RFI Reach ^b	Reaches w/at Least 1 Station in Tier 1	Reaches w/at Least 1 Station in Tier 2 ^c	Reaches w/all Stations in Tier 3	Total # Reaches w/at Least 1 Station Evaluated	Total Reaches in State	% of all Reaches in State w/at Least 1 Station Evaluated	% of Reaches w/at Least 1 or Tier 2 Station
	No.	%	No.	%	No.	%								
Arizona	44	35	58	47	22	18	-	30	33	11	74	1,146	7	5
California	392	27	822	57	229	16	758	75	44	26	145	2,606	6	5
Hawaii	8	22	23	64	5	14	36	-	-	-	-	-	-	-
Nevada	24	25	39	41	33	34	-	16	15	6	37	916	4	3
REGION 9 ^d	468	28	942	55	289	17	794	119	92	43	254	4,601	6	5

^aRiver reaches based on EPA River Reach File 1 (RF1).

^bStations not identified by an RFI reach were located in coastal or open water areas.

^cNo stations in these reaches were included in Tier 1.

^dBecause some reaches occur in more than one state, the total number of reaches in each category for the Region might not equal the sum of reaches in the states.

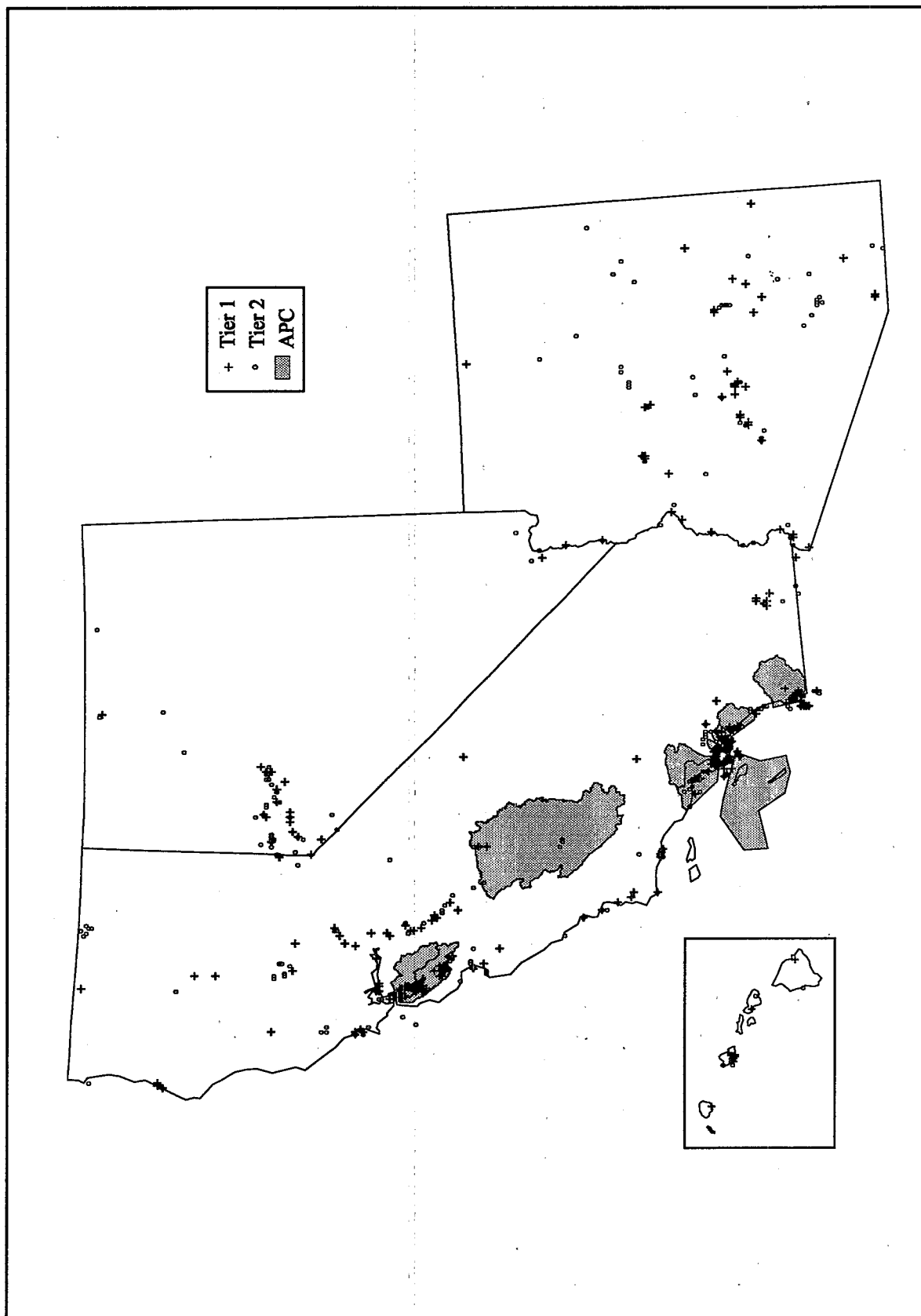

Figure 3-36. Region 9: Location of Sampling Stations Classified as Tier 1 or Tier 2 and Watersheds Containing Areas of Probable Concern for Sediment Contamination (APCs).

Table 3-38. Region 9: Watersheds Containing Areas of Probable Concern for Sediment Contamination

Cataloging Unit Number	Name	State(s)	Number of Sampling Stations			Percent of Sampling Stations in Tier 1 or Tier 2
			Tier 1	Tier 2	Tier 3	
18070104	Santa Monica Bay	CA	79	31	22	83
18070201	Seal Beach	CA	63	339	40	91
18070304	San Diego	CA	53	51	3	97
18070204	Newport Bay	CA	24	68	16	85
18050004	San Francisco Bay	CA	19	37	8	88
18050003	Coyote	CA	18	6	0	100
18070105	Los Angeles	CA	14	19	4	89
18070107	San Pedro Channel Islands	CA	14	10	1	96
18030012	Tulare-Buena Vista Lakes	CA	10	5	5	75
18070301	Aliso-San Onofre	CA	10	22	0	100

Table 3-39. Region 9: Water Bodies With Sampling Stations Classified as Tier 1 Located in Watersheds Containing APCs

Water Body	# of Tier 1 Stations	Water Body	# of Tier 1 Stations
Pacific Ocean	178	Corte Madera Creek	2
San Diego Bay	32	Los Gatos Creek	2
San Francisco Bay	19	Coyote Creek	1
Los Angeles River	14	Lexington Reservoir	1
Santa Catalina Island	14	Oso Creek	1
San Diego Creek	12	Peters Canyon Wash	1
Kings River	10	San Diego River	1
Alamitos Creek	8	San Juan Creek	1
Calero Reservoir	4	Sweetwater River	1
Aliso Creek	2		

Table 3-40. Region 9: Chemicals Most Often Associated with Tier 1 or Tier 2 Sampling Station Classifications*

	Chemical	# Tier 1 & Tier 2 Stations	# Tier 1 Station	# Tier 2 Station		Chemical	# Tier 1 & Tier 2 Stations	# Tier 1 Station	# Tier 2 Station	
Region 9 Overall	Copper	678	--	678	California (continued)	Cadmium	406	--	406	
	DDT	675	179	496		Nickel	373	--	373	
	Arsenic	455	12	443		Arsenic	357	3	354	
	Nickel	454	--	454		Mercury	336	103	233	
	Cadmium	446	--	446		Bis(2-ethylhexyl)phthalat	264	48	216	
	Polychlorinated biphenyls	445	100	345		Lead	253	--	253	
	Mercury	403	134	269		Chromium	239	40	199	
	Lead	314	--	314		Hawaii	Nickel	20	--	20
	Bis(2-ethylhexyl)phthalat	302	69	233			Copper	19	--	19
	Chromium	265	42	223			Mercury	16	4	12
	Zinc	238	--	238	Arsenic		16	1	15	
	Silver	209	23	186	Lead		14	--	14	
	BHC	164	9	155	Zinc	13	--	13		
	Benzo(a)pyrene	158	6	152	DDT	10	2	8		
	Dieldrin	125	--	125	Chromium	10	1	9		
Arizona	Copper	72	--	72	Polychlorinated biphenyls	8	3	5		
	Arsenic	55	8	47	Cadmium	8	--	8		
	Nickel	50	--	50	Nevada	Mercury	29	15	14	
	Lead	37	--	37		Arsenic	27	--	27	
	Zinc	28	--	28		Copper	14	--	14	
	Bis(2-ethylhexyl)phthalat	26	15	11		Nickel	11	--	11	
	Cadmium	24	--	24		Zinc	11	--	11	
	DDT	23	9	14		Lead	10	--	10	
	Mercury	22	12	10		Polychlorinated biphenyls	9	4	5	
Silver	15	7	8	Bis(2-ethylhexyl)phthalat		8	4	4		
California	DDT	640	168	472		Cadmium	8	--	8	
	Copper	573	--	573	Chlordane	8	--	8		
	Polychlorinated biphenyls	418	87	331						

*Stations may be listed for more than one chemical.

EPA Region 10

Alaska, Idaho, Oregon, Washington

EPA evaluated 2,878 sampling stations in Region 10 as part of the NSI evaluation. Sediment contamination where associated adverse effects to aquatic life are probable (Tier 1) was found at 623 of these sampling stations, and possible but infrequent (Tier 2) at 1,658 of these sampling stations. For human health, data for 112 sampling stations indicated probable association with adverse effects (Tier 1), and 1,285 sampling stations indicated possible but infrequent adverse effects (Tier 2). Overall, this evaluation resulted in the classification of 727 sampling stations (25 percent) in Region 10 as Tier 1, 1,696 (59 percent) as Tier 2, and 455 (16 percent) as Tier 3. The NSI sampling stations in Region 10 were located in 393 separate river reaches, or 4 percent of all reaches in the Region. One percent of all river reaches in Region 10 included at least one Tier 1 station, 2 percent included at least one Tier 2 station but no Tier 1 stations, and 1 percent had only Tier 3 stations (Figure 3-37). Table 3-41 (on the following page) presents a summary of sampling station classification and evaluation of river reaches for each state and for the Region as a whole.

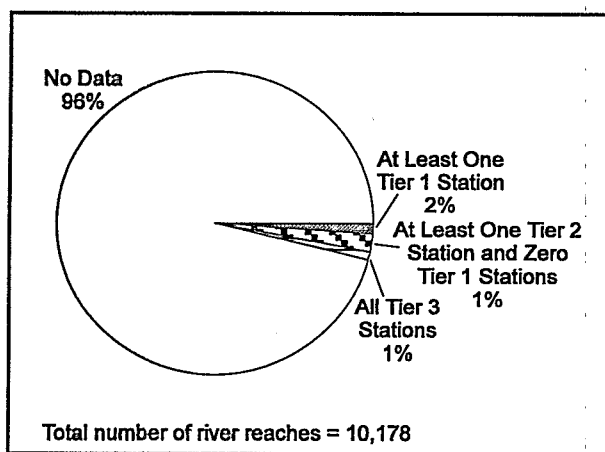

Figure 3-37. Region 10: Percent of River Reaches That Include Tier 1, Tier 2, and Tier 3 Sampling Stations.

This evaluation identified 7 watersheds containing areas of probable concern for sediment contamination (APCs) out of the 219 watersheds (3 percent) in Region 10 (Figure 3-38). In addition, 28 percent of all watersheds in the Region had at least one Tier 1 sampling station but were not categorized as containing APCs, 14 percent had at least one Tier 2 station but no Tier 1 stations, and 6 percent had only Tier 3 stations. Forty-nine percent of the watersheds in Region 10 did not include a sampling station. The locations of the watersheds containing APCs and the Tier 1 and Tier 2 sampling stations in Region 10 are illustrated in Figure 3-39.

Within the 7 watersheds in Region 10 identified as containing APCs (Table 3-42), 34 water bodies have at least 1 Tier 1 sampling station; 8 water bodies have 10 or more Tier 1 sampling stations (Table 3-43). Puget Sound appears to have the most significant sediment contamination in Region 10. The water bodies listed on Table 3-43 are not inclusive of all locations containing a Tier 1 sampling station because only water bodies within watersheds containing APCs are listed.

The chemicals most often associated with Tier 1 or Tier 2 sampling station classifications in Region 10 overall and in each state in Region 10 are presented in Table 3-44.

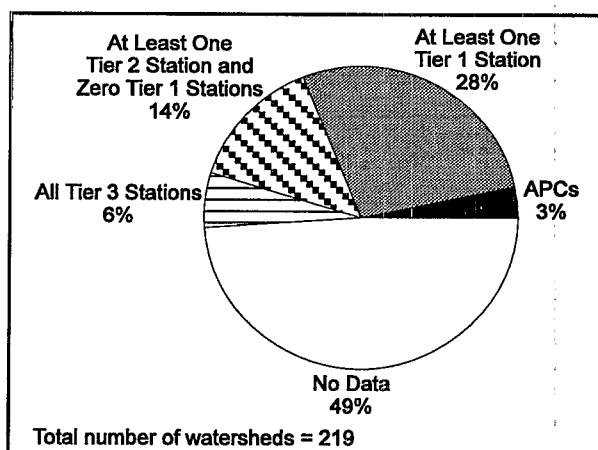

Figure 3-38. Region 10: Watershed Classifications.

Table 3-41. Region 10: Evaluation Results for NSI Sampling Stations and River Reaches by State

State	Station Evaluation				River Reach Evaluation ^a									
	Tier 1		Tier 2		Tier 3		Number of Stations Not Identified by an RFI Reach ^b	Reaches w/at Least 1 Station in Tier 1	Reaches w/at Least 1 Station in Tier 2 ^c	Reaches w/all Stations in Tier 3	Total # Reaches w/at Least 1 Station Evaluated	Total Reaches in State	% of all Reaches in State w/at Least 1 Station Evaluated	% of Reaches w/at Least 1 or Tier 2 Station
	No.	%	No.	%	No.	%								
Alaska	21	8	191	71	55	21	267	-	-	-	-	-	-	-
Idaho	43	45	36	38	16	17	-	30	16	7	53	3,227	2	1
Oregon	81	28	158	54	52	18	2	45	43	25	113	4,203	3	2
Washington	582	26	1,311	59	332	15	228	75	115	40	230	2,924	8	6
REGION 10 ^d	727	25	1,696	59	455	16	497	147	174	72	393	10,178	4	3

^aRiver reaches based on EPA River Reach File 1 (RF1).^bStations not identified by an RFI reach were located in coastal or open water areas.^cNo stations in these reaches were included in Tier 1.^dBecause some reaches occur in more than one state, the total number of reaches in each category for the Region might not equal the sum of reaches in the states.

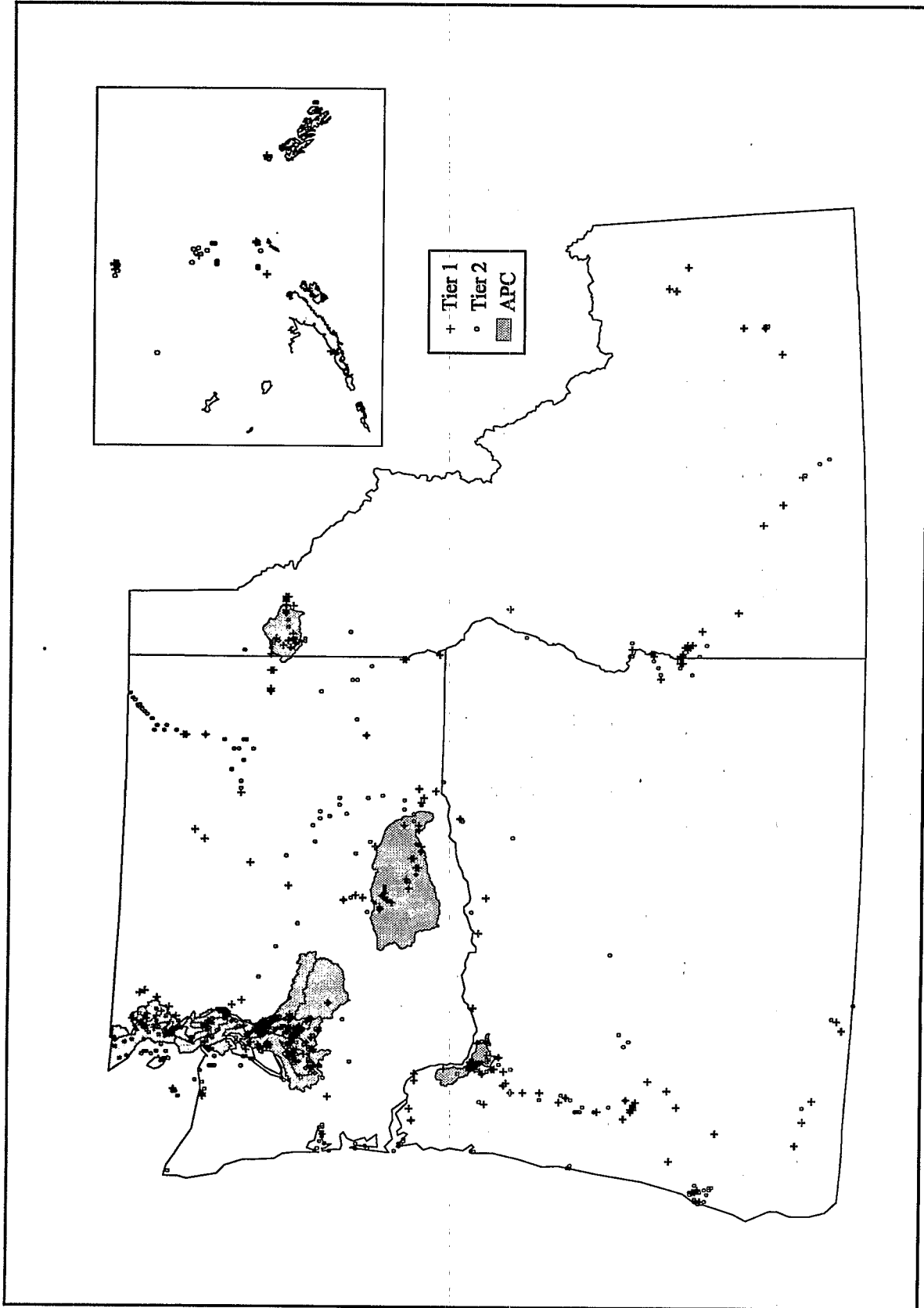

Figure 3-39. Region 10: Location of Sampling Stations Classified as Tier 1 or Tier 2 and Watersheds Containing Areas of Probable Concern for Sediment Contamination (APCs).

Table 3-42. Region 10: Watersheds Containing Areas of Probable Concern for Sediment Contamination

Cataloging Unit Number	Name	State(s)*	Number of Sampling Stations			Percent of Sampling Stations in Tier 1 or Tier 2
			Tier 1	Tier 2	Tier 3	
17110019	Puget Sound	WA	418	851	114	92
17110013	Duwamish	WA	48	69	10	92
17110002	Strait Of Georgia	WA	32	168	63	76
17030003	Lower Yakima	WA	23	19	5	89
17090012	Lower Willamette	OR	21	51	4	95
17110014	Puyallup	WA	12	6	1	95
17010303	Coeur D'Alene Lake	ID, (WA)	10	13	0	100

*No data were available for states listed in parentheses.

Table 3-43. Region 10: Water Bodies With Sampling Stations Classified as Tier 1 Located in Areas of Probable Concern for Sediment Contamination

Water Body	# of Tier 1 Stations	Water Body	# of Tier 1 Stations
Puget Sound	306	Lake Whatcom	2
Budd Inlet	41	Sammish Bay	2
Elliot Bay	41	Sammish River	2
Bainbridge Island	31	Whidbey Island	2
Sinclair Inlet	28	Spring Creek	2
Bellingham Bay	22	Thompson Lake	2
Yakima River	19	Ahtanum Creek	1
Willamette River	10	Camano Island	1
Carbon River	8	Duwamish Waterway	1
Columbia Slough	8	Fidalgo Island	1
Green River	6	Padden Lake	1
Coeur D'alene Lake	4	Port Orchard	1
Dyes Inlet	4	Port Susan	1
Puyallup River	4	Spanaway Lake	1
Coeur D'alene River	3	Toppenish Creek	1
Johnson Creek	3	White Hall Creek	1
Chambers Creek	2	Wolf Lodge Creek	1

Table 3-44. Region 10: Chemicals Most Often Associated with Tier 1 or Tier 2 Sampling Station Classifications*

	Chemical	# Tier 1 & Tier 2 Stations	# Tier 1 Station	# Tier 2 Station		Chemical	# Tier 1 & Tier 2 Stations	# Tier 1 Station	# Tier 2 Station
Region 10 Overall	Copper	1,518	--	1,518	Idaho (continued)	Cadmium	29	--	29
	Nickel	1,409	--	1,409		Copper	28	--	28
	Arsenic	1,231	55	1,176		Zinc	28	--	28
	Lead	881	--	881		DDT	25	--	25
	Benzo(a)pyrene	803	103	700		Dieldrin	21	--	21
	Pyrene	770	160	610		Toxaphene	14	--	14
	Mercury	760	133	627		Silver	11	8	3
	Cadmium	754	--	754		Oregon	Copper	125	--
	Polychlorinated biphenyls	710	289	421	Nickel		107	--	107
	Dibenzo(a,h)anthracene	709	245	464	Arsenic		86	1	85
	Chrysene	704	86	618	Polychlorinated biphenyls		84	46	38
	Benzo(a)anthracene	669	107	562	DDT		73	19	54
	Naphthalene	589	104	485	Zinc		59	--	59
	Fluorene	547	77	470	Mercury		53	7	46
Chromium	546	17	529	Cadmium	51		--	51	
Alaska	Chromium	135	12	123	Chromium	46	3	43	
	Arsenic	89	--	89	Lead	44	--	44	
	Copper	50	--	50	Washington	Copper	1,315	--	1,315
	Nickel	41	--	41		Nickel	1,256	--	1,256
	Cadmium	35	--	35		Arsenic	1,017	41	976
	Naphthalene	31	2	29		Lead	788	--	788
	Polychlorinated biphenyls	29	2	27		Benzo(a)pyrene	754	101	653
	Zinc	29	--	29		Pyrene	735	156	579
	Phenanthrene	26	--	26		Mercury	683	121	562
Fluorene	22	--	22	Chrysene		682	83	599	
Idaho	Arsenic	39	13	26	Dibenzo(a,h)anthracene	681	240	441	
	Polychlorinated biphenyls	32	28	4	Benzo(a)anthracene	646	104	542	
	Lead	32	--	32					

*Stations may be listed for more than one chemical.

Potentially Highly Contaminated Sites Not Identified by the NSI Evaluation

Several Regions and states provided comments on the May 16, 1994, preliminary evaluation of sediment chemistry data contained in the NSI. They identified receiving streams that should have been but were not identified as locations of potential adverse effects, based

on the NSI data evaluation. The specific water bodies that reviewers of the preliminary evaluation identified as potentially contaminated, but which are not presently included in the NSI because data are inadequate to categorize sampling stations as Tier 1, are presented in Table 3-45 and Figure 3-40. If a water body had previously been identified as having at least one Tier 1 sampling station using the NSI evaluation methodology, it was not included in Table 3-45 or Figure 3-40.

Table 3-45. Potentially Highly Contaminated Sites Not Identified in the NSI Evaluation

Water Body	EPA Region	State	Chemicals Potentially Present
Onandaga Lake	2	NY	pesticides, metals, PAHs, PCBs
Ley Creek	2	NY	mercury
Kill van Kull	2	NY	metals, dioxin
Newtown Creek	2	NY	PAHs
Scajaquada Creek	2	NY	metals, PCBs
Skaneateles Creek	2	NY	PCBs
Hudson River	2	NY	PCBs
Southern reaches of the Maurice River	2	NJ	arsenic
Elizabeth River	3	VA	PAHs
James River	3	VA	kepone
Anacostia River	3	DC	chlordan, PCBs
Lake O' the Pines	6	TX	lead, zinc
Linneville Bayou	6	TX	lead, chromium
Humboldt River Basin	9	NV	selenium
Dry Lake	9	AZ	dioxin

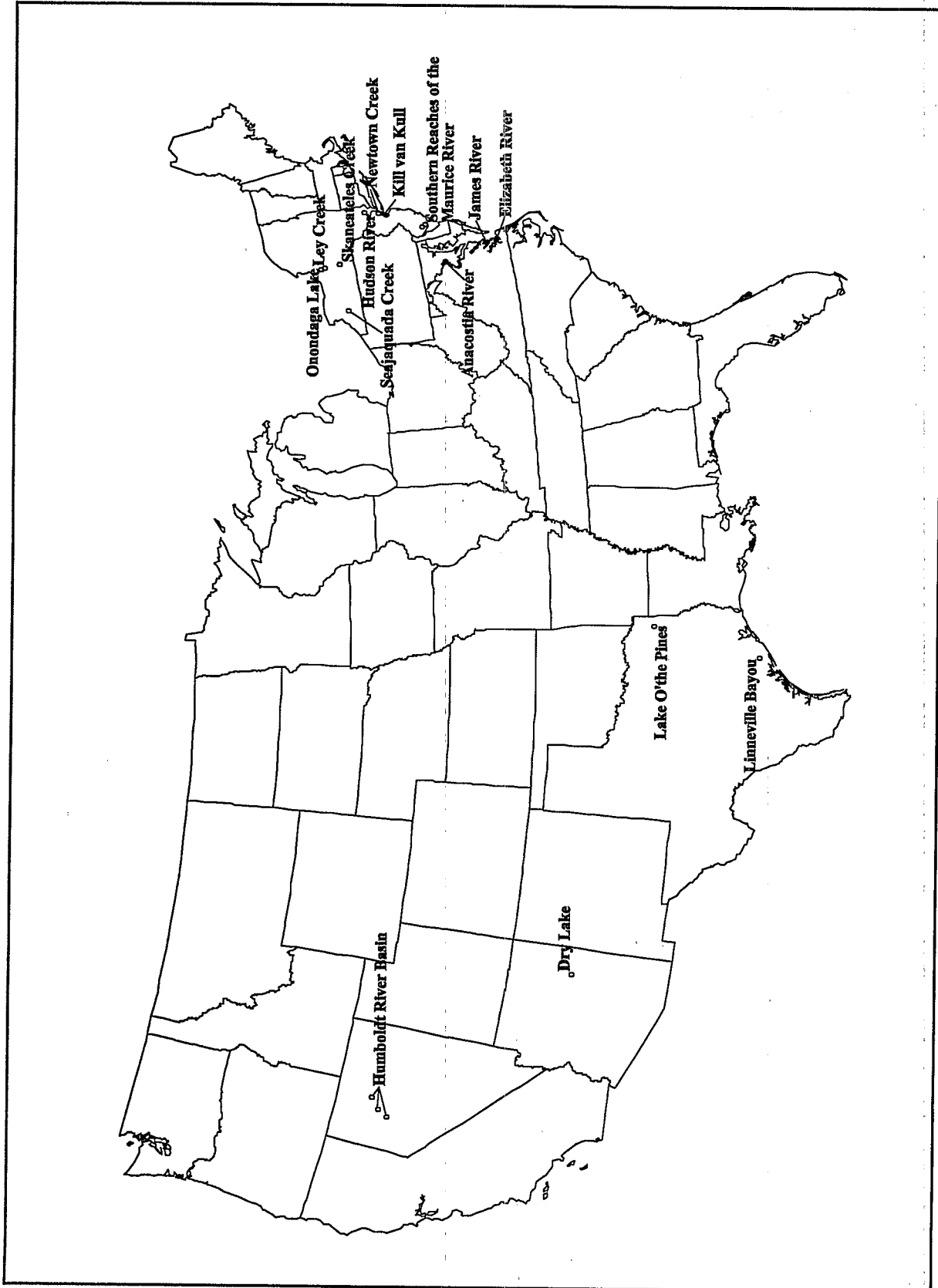

Figure 3-40. Location of Potentially Highly Contaminated Water Bodies Not Identified in the NSI Evaluation.

Chapter 4

Pollutant Sources

Toxic chemicals that accumulate in sediment and are associated with contamination problems enter the environment from a variety of sources. These sources can be broadly differentiated as point sources and nonpoint sources. The term "point source" is defined in the Clean Water Act (CWA) and generally refers to any specific conveyance, such as a pipe or ditch, from which pollutants are discharged. In contrast, nonpoint sources do not have a single point of origin and generally include diffuse sources, such as urban areas or agricultural fields, that tend to deliver pollutants to surface water during and after rainfall events. Some sources, such as landfills and mining sites, are difficult to categorize as either a point or nonpoint source. Although these land areas represent discrete sources, pollution from such areas tends to result from rainfall runoff and leaching. Likewise, atmospheric deposition of pollutants, generally considered to be a nonpoint source of water pollution, arises from the emission of chemicals from discrete stationary and mobile source points of origin. The CWA specifies water vessels and other floating craft as point sources although, taken as a whole, they function as a diffuse source.

Many point and nonpoint pollutant sources have been the subject of federal and other action over the past 25 years. The direct discharge of pollutants to waterways from municipal sewage treatment and industrial facilities requires a permit under the CWA. Many states have been authorized to issue permits in lieu of EPA. These permits contain technology-based and water quality-based pollutant discharge limits and monitoring requirements. More recently, replacement of aging combined sewer systems and other storm water control measures has addressed the discharge of pollutants from urban areas through municipal facilities. The disposal of sediment dredged to maintain navigation channels is managed under both the CWA and the Marine Protection, Research, and Sanctuaries Act (MPRSA) to ensure that unacceptable degradation from chemical pollutants in the dredged material does not occur at the disposal location. Emission standards and controls on stationary and mobile sources of air pollutants have also been established in federal regulations promulgated under the authority of the Clean Air Act (CAA). These actions have reduced emissions of gaseous compounds such as inorganic oxides, as well as pollutants that eventually

enter water bodies and accumulate in sediment. The Toxic Substances Control Act (TSCA) and Federal Insecticide, Fungicide, and Rodenticide Act (FIFRA) have greatly reduced the toxic pollutant input to the environment through bans and use restrictions on many pesticides and industrial-use chemicals.

Federal, state, and local laws have also addressed land-based pollutant sources. Under the Resource Conservation and Recovery Act (RCRA), the transport, storage, and disposal of pollutants in landfills and other repositories of hazardous waste are tracked and controlled. At sites where past disposal practices, either purposeful or accidental, have resulted in severe contamination, remediation has been undertaken under the federal Superfund laws. Where applicable, land development projects may be subject to an assessment of the environmental impact conducted under National Environmental Policy Act (NEPA) authority. Under the authority of the Coastal Zone Management Act (CZMA), EPA has developed nonregulatory management measures to reduce pollutant delivery via nonpoint sources, such as runoff from urban and agricultural areas.

The combined impact of these actions has yielded improvements in water quality. In at least some documented cases, pollutant levels in sediment are also decreasing. (For example, see the discussion of the Palos Verdes case study presented in Chapter 5.) However, improvement in sediment quality might lag behind improvement in overlying water because of the persistent nature of many pollutants, as well as the storage and sink functions of sediment, and because the most toxic bioaccumulative pollutants are difficult to monitor and regulate. It is beyond the scope of this baseline assessment to determine the temporal trends of pollutant concentrations in sediment on a national scale. Future reports to Congress will address that issue.

Natural recovery of contaminated sediment can occur through source reduction, contaminant degradation, and continuing deposition of clean sediment. The feasibility of natural recovery, as well as the long-term success of remediation projects, depends on the effective control of pollutant sources. For some classes of sediment contaminants, such as PCBs and organochlorine

pesticides, use and manufacture bans or severe restrictions have been in place for many years. Past disposal and use of PCBs continue to result in evaporation of these contaminants from some landfills and leaching from soils, but most active PCB sources have been controlled. The predominant sources of organochlorine pesticides are runoff and atmospheric deposition from past applications on agricultural land, and occasional discharge from municipal treatment facilities. For other classes of sediment contaminants, active sources continue to contribute substantial environmental releases. For example, liberation of inorganic mercury from fuel burning and other incineration operations continues, as do urban runoff and atmospheric deposition of metals and PAHs. In addition, discharge limits for municipal and industrial point sources are based on technology-based limits and state-adopted standards for protection of the water column, not necessarily for downstream protection of sediment quality. Determining the local and far-field effects of individual point and nonpoint sources on sediment quality usually requires site-specific study.

The purposes of this chapter are to:

- Present the extent of sediment contamination by chemical class in the 96 watersheds identified as areas of probable concern for sediment contamination (APCs).
- Identify the major source categories of these chemical classes and summarize key studies that link these source categories to sediment contamination.
- Analyze land use patterns and the extent of sediment contamination by chemical class in the 96 APCs.
- Briefly describe current EPA efforts to further characterize point and nonpoint sources of sediment contaminants.

Extent of Sediment Contamination by Chemical Class

The individual chemicals evaluated for this report can be grouped into six chemical classes: metals, PCBs, pesticides, mercury, PAHs, and other organic chemicals. Pesticides include the organochlorine pesticide compounds assessed in this report, such as DDT and metabolites, dieldrin, and chlordane. PAHs include both low- and high-molecular-weight polynuclear aromatic hydrocarbons, and other organ-

ics include all organics not otherwise classified. Mercury is grouped separately from other metals because of its unique behavior in the environment (e.g., methylation and bioaccumulation potential) and because of recent attention focused on its impact as a primary sediment and fish contaminant of concern.

Figure 4-1 presents, by chemical class, the average percent of stations that are contaminated in the 96 APCs. For this analysis, the percent contamination is derived by taking the number of stations where an individual chemical constituent of a particular chemical class places a station into Tier 1 or Tier 2 and dividing by the total number of stations in the watershed. Each constituent, or any constituent representative of a chemical class, might not have been measured at all stations in the watershed. In addition, the total number of stations in each watershed varies extensively, as does the spatial extent of sampling within the watershed. The resulting percent contamination by chemical class varies a great deal—from 0 percent to 100 percent for each class—among the watersheds. Figure 4-1 presents the average value at both Tier 1 and combined Tier 1 and Tier 2 contamination levels.

Figure 4-1 indicates that at the Tier 1 level of contamination, PCBs are the dominant chemical class with an average extent of contamination of 29 percent. Among Tier 1 stations, all other classes of contaminants account for contamination at a lower percent of the stations on the average (6 to 10 percent). The relative importance of PCBs reflects, in part, the fact that a station can be designated Tier 1 for human health effects based on elevated fish tissue concentrations alone for this chemical class, whereas elevated levels in fish tissue and corresponding elevated levels in sediment are required for all other classes. At the combined Tier 1 and Tier 2 level of contamination, metals are the dominant chemical class measured by average extent of contamination (59 percent), followed by PCBs and pesticides (both at 43 percent), mercury (29 percent), and PAHs and other organics (19 and 14 percent, respectively). The very large increase in the relative importance of metals from Tier 1 to combined Tier 1 and Tier 2 also reflects the evaluation methodology because a divalent transition metal concentration cannot place a station into Tier 1 without an accompanying acid-volatile sulfide concentration ([AVS]) measurement, which is typically not available.

Figure 4-1 graphically displays the relative differences in certainty of assessing the probable effects of metals versus assessing the effects of PCBs. More confidence can be placed in the assertion that PCBs exhibit "probable association with adverse effects" than in mak-

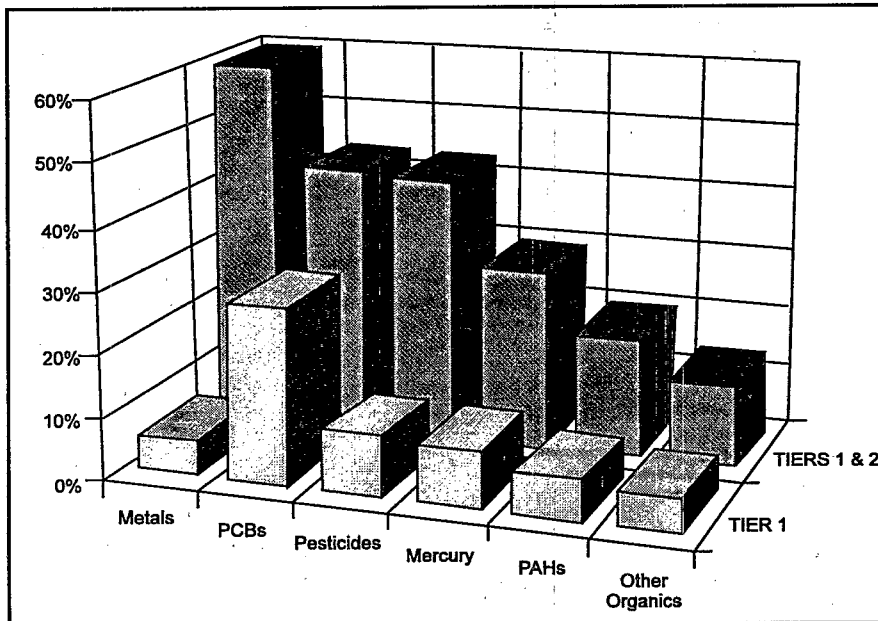

Figure 4-1. Average Percent Contamination in Watersheds Containing APCs by Chemical Class.

ing this assertion for metals. The relatively high percent of PCB contamination at the Tier 1 level reflects the relative certainty that elevated PCB levels in fish are associated with elevated levels in sediment. The relatively low percent of metal contamination at the Tier 1 level primarily reflects the lack of confirming data (i.e., AVS) regarding important binding phases and bioavailability, not necessarily the lack of significance of metal contamination. In fact, the very high percent contamination indicated at the combined Tier 1 and Tier 2 level demonstrates the potential importance of this chemical class. It should also be noted, however, that correlative screening values such as ERM_s do not indicate causality, rather they are concentrations *associated* with effects.

This analysis does not imply that certain chemical classes are always dominant, nor that other chemical classes can be dismissed altogether. In fact, contamination from constituents in any class may be of paramount importance in a given watershed or location. The differences in extent of chemical class contamination on the average in the 96 APCs is intended to provide some perspective to the ensuing sections of this chapter.

Major Sediment Contaminant Source Categories

To identify the important sources of sediment contaminants, EPA searched the scientific and technical literature for studies that link specific pollutant sources to

evidence of sediment contamination. EPA focused this review on studies appearing in peer-reviewed journals and government reports published after 1980. The majority of studies related sediment contamination to a source through qualitative means, including associations of land use or specific activity with the types of contaminants detected, and spatial analyses. For example, organochlorine pesticide contamination is associated with agricultural land use where past application practices and hydrologic routes of rainfall runoff are known. Some researchers made the association with contamination source by more quantitative means such as loadings measurements, runoff or deposition estimates, or mass balance

models of contaminant inputs. Most research has focused on the chemicals or chemical classes listed above. The studies reviewed attributed sediment contamination from the six classes of chemicals to four general nonpoint source categories and two general point source categories. Table 4-1 summarizes the correlations of source category to chemical class documented in literature.

Table 4-1 does not specifically list some important sources that are difficult to categorize as a point or nonpoint source. These sources include leachate from landfills, direct inputs from recreational and commercial boating, and disposal of contaminated dredged material. As mentioned at the beginning of this chapter, landfills are not easily classified as a point or nonpoint source. Evaporation and subsequent deposition of moderately volatile contaminants from landfills represent an atmospheric source, yet leachate is typically considered as neither "urban runoff" nor a controlled point source. Nonetheless, leachate from landfills is an important documented source of sediment contaminants. For example, landfill leachate and past effluent discharges from electronics manufacturers have contaminated New Bedford Harbor in Massachusetts with PCBs and heavy metals (Garton et al., 1996). Boating and shipping activities can be important sources of a variety of contaminants, including PAHs and antifouling paint additives such as tributyl tin and copper. As for dredged material disposal, past dredging operations to maintain navigation channels could be responsible for contaminated sediment at specifically designated dump sites. Dredging

Table 4-1. Correlations of Sources to Chemical Classes of Sediment Contaminants

Source/Chemical Class	Mercury	PCBs	PAHs	Metals	Pesticides	Other Organics
Harvested Croplands					★	
Inactive and Abandoned Mine Sites	●			●		
Atmospheric Deposition	●	●	●	●	●	●
Urban Sources	●		●	●	★	●
Industrial Discharges	●	★	●	●	★	●
Municipal Discharges	●	●	●	●	●	●

★ Source from past activities
 ● Ongoing source

practices are currently managed under federal, state, and local authority to ensure that appropriate testing and safe disposal occur. In addition to these sources, uncontrollable and accidental point source releases, such as improper disposal practices and spills, have occurred and continue to occur.

A notable feature of Table 4-1 is the extent to which multiple sources can be associated with each chemical class. This is the primary factor in making source assessment and effective source control such difficult tasks. The table does not provide any indication of which sources are the most significant. The significance of any given source depends on the areal extent of the source and intensity of the activity in the watershed. Because a variety of sources are present (or were present in the past) in most watersheds, and the extent and intensity of each source vary, the most important source of a particular chemical or class of chemical contaminants at a given location also varies. In addition, there is typically overlap among source categories. The most obvious overlap is between atmospheric deposition and urban sources. For example, fuel combustion in urban areas releases PAHs to the atmosphere, which are subsequently deposited in various parts of the watershed or transported to other areas.

Despite these cautions, the results of EPA's literature review allow some broad assertions regarding source associations. For harvested croplands, organochlorine pesticides are the major contaminants of concern. Inactive and abandoned mine sites contribute mercury and other heavy metals to sediment. Atmospheric deposition is a primary contributor of mercury, PCBs, and PAHs. Urban sources are most closely associated with metals and PAHs. Although permit monitoring records

and industry-supplied release estimates, as well as specific spatial analysis studies, indicate that municipal and industrial discharges of sediment contaminants (particularly metals and other organics) continue, the relative contribution compared to nonpoint sources is an open question and undoubtedly varies substantially by watershed. A brief summary of the literature review for major source categories follows.

At many sites, elevated levels of pesticides in the Nation's sediment can be attributed to past agricultural practices. Crop growers deliberately apply pesticides to protect their yield from insects, fungus, and weeds. In the past, organochlorine compounds such as DDT and chlordane were used without restriction to rid harvested croplands of a broad range of unwanted species. These compounds tend to be persistent in the environment, adsorptive to soil and sediment particles, highly bioaccumulative in living tissue, and lethal to many non-target organisms. As these effects became apparent and regulatory authorities began restricting or banning the use of persistent pesticides in the United States, chemical manufacturers developed newer organophosphate pesticides that might be more easily degradable and, in some cases, more narrowly targeted to specific organisms. In addition, modern pesticides must undergo federal registration procedures designed to protect human health and the environment before they can be approved for intended new uses.

Although the current-use pesticides are applied throughout the country in large amounts, they are not frequently analyzed in routine sediment monitoring, nor are they frequently detected in sediment when included in monitoring studies (Pereira et al., 1994). Because of the lack of monitoring data, and the absence of available levels of concern in sediment, current-use pesticides were not included in this evaluation of sediment quality. However, these compounds exhibit toxicity to non-target organisms. Furthermore, although these compounds have shorter half-lives and greater water solubility than organochlorines in general, the chemical and physical properties of some of these compounds indicate significant bioconcentration potential (Willis and McDowell, 1983). Thus, further assessment of the presence of current-use pesticides in fish and sediment is warranted.

The discharge of pollutants from agricultural lands to surface water is largely driven by precipitation. Contaminants also reach the aquatic ecosystem via irrigation return flows through interflow or ground water seepage. Most of the literature reviewed identifies agriculture as the source of pesticides in sediment because of upstream land use, chemical use, and the nature of the chemicals detected in sediments. Contamination of sediment associated with major agricultural areas of the United States has been reported in numerous studies. For example, the San Joaquin River, in the highly agricultural central valley of California, has bed-sediment concentrations of the pesticides DDT and dieldrin among the highest of all major rivers in the United States (Gilliom and Clifton, 1990). Researchers have also found continued elevated levels of highly persistent organochlorines in bottom-feeding fish, a condition that is often a consequence of sediment contamination. In the Yakima River in Washington, which drains a largely agricultural region, concentrations of DDT in fish for the years 1989-90 were found to be similar to concentrations for the years 1970-76 (USGS, 1993).

Contaminant contributions from past mining activities are so significant that several former mining sites in the United States have been included on the EPA Superfund Program's National Priorities List of sites for remediation, including the Clark Fork River Basin in Montana, the Bunker Hill Complex in Idaho, White-wood Creek and the Belle Fourche River in South Dakota, Tar Creek in Oklahoma, Iron Mountain in California, and the Arkansas River and tributaries near Leadville, Colorado. The persistence and mobility of heavy metals have resulted in concentrations in sediments up to 65 miles downstream of discharge similar to the elevated concentrations found in the mine tailings themselves (Henny et al., 1994). Based on information provided by the states, the Bureau of Mines estimated that abandoned coal and metal mines and their associated wastes adversely affect more than 12,000 miles of rivers and streams and more than 180,000 acres of lakes and reservoirs (Kleinman, 1989).

The primary sediment contaminants of concern associated with mining are heavy metals such as lead, mercury, zinc, cadmium, copper, manganese, and silver. These metals are primarily associated with historical mining of silver, gold, lead, and zinc. A literature review of studies related to mining pollution provided publications describing the effects of mining on water quality; however, few researchers have directly addressed the effects of mining on sediments. A monitoring study performed on Idaho's Lake Coeur d'Alene surface sediment found that ores and wastes from a mining district

were the source of elevated sediment concentrations of several heavy metals via transport down the Coeur d'Alene River (Horowitz et al., 1993). Moore et al. (1991) performed an integrated sediment-water-biota monitoring study on the effects of acid mine effluent on the Blackfoot River in Montana. These researchers found elevated levels of heavy metals in sediment from tributaries with known historical mine effluent input that were higher than levels in nonaffected tributaries. In another study from the gold mining region of northern Georgia, elevated mercury concentrations decreased as distance of the sampling sites from the mining district increased (Leigh, 1994). The author further suggests that similar occurrences of mercury contamination could exist throughout the gold mining region of the Southern Piedmont because of the historical amalgamation processes used by gold miners.

Atmospheric deposition is often identified as a major source of mercury, PCBs, and PAHs to aquatic systems. Studies have also implicated atmospheric sources as an important contributor of metals. Sources that emit large amounts of many toxic chemicals to the atmosphere include industrial point sources, fuel combustion in motor vehicles, volatilization of compounds from landfills and open water, combustion of wood and other fuels to produce heat, and waste incineration. In addition, long-range atmospheric transport of organochlorine pesticides from countries where their use is still permitted contributes these compounds to aquatic environments in this country (Keeler et al., 1993).

Atmospheric sources of mercury include coal combustion, waste incineration, and paint application. Sorensen et al. (1990) compared mercury levels in sediment cores from lakes in northern Minnesota with precipitation loadings from monitoring and concluded that, on the average, direct wet atmospheric deposition accounts for 60 percent of the mercury in lake sediment. A 1994 EPA report to Congress entitled *Deposition of Air Pollutants to the Great Waters* also describes mass balance studies from Wisconsin and Sweden indicating that atmospheric deposition is responsible for most of the mercury in lakes (USEPA, 1994a). The Swedish study also points out that mercury deposited onto forest soils is stored, for potentially long periods of time, before it enters the lake through storm water runoff. This further illustrates the relationship between atmospheric deposition and runoff.

Sources of PCBs to the atmosphere include municipal and hazardous waste landfills, refuse and sewage sludge incinerators, and occasional leakage from electrical transformers and capacitors (Keeler et al., 1993).

Researchers have developed a mass balance for PCBs in Lake Superior that indicates that approximately 77 to 89 percent of the annual PCB input to the lake is from atmospheric deposition (Baker et al., 1993, cited in USEPA, 1994a). These researchers have also estimated the percent contribution of PCBs from atmospheric deposition for other Great Lakes, keeping track of the fraction contributed from atmospheric deposition to upstream lakes. For example, about 63 percent of PCB input to Lake Huron is from direct atmospheric deposition, an additional 15 percent is from atmospheric deposition to the upstream Lakes Superior and Michigan, and the remaining 22 percent is from other sources. Lakes Erie and Ontario receive only about 13 percent and 7 percent, respectively, of their annual PCB load from atmospheric sources.

Sources of atmospheric PAHs include stationary fuel combustion, industrial production facilities, transportation, solid waste incineration, and forest and prairie fires. Routine installation of catalytic converters in motor vehicles, as well as other combustion emission controls, have decreased PAH releases to the atmosphere. Atmospheric transport of PAHs generated during fuel combustion has often been inferred to account for the appearance of PAHs in soils and sediments in regions distant from known combustion sources, but quantification of this process is scarce in the literature (Prahl et al., 1984). Researchers typically state that the types of PAHs detected in sediments at a particular study site are indicative of combustion sources, thereby implying that atmospheric deposition is probably the primary source to the aquatic environment (Helfrich and Armstrong, 1986; Rice et al., 1993). In a rare attempt to quantify this contribution, Prahl et al. (1984) studied atmospheric particulate matter and surface sediment in Washington State coastal sediments and estimated that atmospheric transport accounted for about 10 percent of the PAHs in sediment. However, unlike the examination of PCBs in the Great Lakes described above, the authors did not account for the atmospheric contribution to upstream waterborne inputs.

Metals are released to the atmosphere from sources such as primary and secondary metal production and, in the past, use of leaded gasoline. Mass balance studies of metal inputs to the aquatic environment have identified atmospheric deposition as an important contributor, but less significant than riverine and upstream sources. As was the case with the PAH mass balance in Washington, these studies do not identify the atmospheric portion of riverine or upstream sources. In one study, estimates of loadings to Narragansett Bay, Rhode Island, indicated that atmospheric deposition contributes 2 per-

cent of copper and zinc and 33 percent of lead in sediment (Bricker, 1993). Based on a mass balance study on Delaware Bay, direct atmospheric deposition accounts for 7 percent of the cadmium loading to the bay; rivers (72 percent) and salt marshes (21 percent) account for the remaining cadmium input. Some portion of the riverine input originates from the air (USEPA, 1994a).

Atmospheric deposition is a significant source of dioxins and furans found in sediment. These highly persistent compounds are grouped with "other organics" in Figure 4-1. Municipal and industrial waste incineration and residential and industrial wood combustion were both listed as important sources of dioxins and furans to the environment in two recent reviews (Voldner and Smith, 1989 and Johnson et al., 1992, cited in Keeler et al., 1993).

The category "urban sources" refers broadly to runoff from roadways, residential and commercial areas, construction sites, and marinas and shipyards. According to EPA's National Urban Runoff Program (NURP) studies, the principal toxic pollutants found in urban runoff are metals, oil and grease, PAHs, and petroleum hydrocarbons (USEPA, 1992b). Much of the pollution in urban runoff is associated with atmospheric deposition, particularly for mercury and PAHs. Other classes of chemicals, such as metals and petroleum hydrocarbons, have many land-based sources. Lead was formerly contributed by car exhaust, but most contributions now come from exterior paints and industrial runoff. Cadmium is also associated with paints. Zinc is associated with weathering and abrasion of galvanized iron and steel. Car brake linings and leaching and abrasion of copper pipes and brass fittings contribute copper to runoff. Chromium is contributed to runoff through car and machinery corrosion (Cohn-Lee and Cameron, 1991). Sources of petroleum hydrocarbons include disposal of automobile and industrial lubricants, spillage from oil storage facilities, and leakage from motor vehicles (Brown et al., 1985). In addition to agricultural uses, organochlorine pesticides were also used extensively in urban and residential areas for a variety of pest control purposes.

The association of urban sources and metal enrichment of sediment is well documented in the literature. For example, a study of storm water detention ponds in Florida, Virginia, Maryland, and Minnesota found that metal concentrations in surface sediments were typically 5 to 30 times higher than those in the parent soils (Schueler, 1994). This study also reported the highest metal concentrations in ponds associated with industrial land use, followed by those associated with roads

and commercial land use, then those associated with residential land use. In contrast to atmospheric transport, which can carry pollutants far from their original source, runoff of metals tends to affect areas in close proximity to the source. For example, Yousef et al. (1985) sampled water and sediments in detention ponds in Florida and found that metals from highway runoff are retained by bottom sediments close to the point of entry to the waterway.

Hydrocarbons, PAHs, and mercury are also frequently associated with urban sources. Using analytical chemistry techniques, Brown et al. (1985) discovered that crankcase oil was a primary contributor to sediment hydrocarbon contamination in Tampa, Florida. Gas chromatograms of used crankcase oil, storm water runoff, and sediment samples all showed similar peaks, indicating that the type of petroleum found in sediment very closely resembled that found in storm water runoff. Sources of PAHs that are concentrated in urban areas include emissions from commercial and residential fuel-burning furnaces and vehicular emissions. An inventory of sediment contamination in Casco Bay, Maine, showed that the highest PAH concentrations occurred at locations closest to the city of Portland (Kennicutt et al., 1994). Mastran et al. (1994) found that sediments from urban areas tend to have lower fluoranthene/pyrene ratios than those from remote areas. These ratios are indicative of pollution caused by gas exhaust residues in urban runoff. A study of ambient air in the southern Lake Michigan basin revealed that concentrations of mercury, both gaseous and particulate, are significantly higher (approximately 5 times higher) in the Chicago urban/industrial area than levels measured at the same time in surrounding areas (Keeler, 1994, as reported in USEPA, 1994a).

In addition to the nonpoint source categories discussed above, municipal and industrial point sources have been associated with sediment contaminated by each of the chemical classes examined in this report. Much of this contamination has been caused by past industrial and municipal discharges. For example, sediment core samples from southwestern Long Island, New York, revealed levels of metals that increased to several times the preindustrial concentrations, then decreased approximately 50 percent between the mid-1960s and late 1980s. PCBs, chlordane, and other chlorinated organics in sediment also decreased between the late 1960s and the late 1980s. Local improvements in wastewater treatment and national efforts to restrict the use of specific chemicals are cited as explanations for the declines (Bopp et al., 1993). As previously mentioned, past ef-

fluent discharges from electronics manufacturers are linked to PCB contamination in New Bedford Harbor, Massachusetts (Garton et al., 1996; Lake et al., 1992). Perhaps the best example of pesticide contamination in sediment from past industrial activity is kepone in the James River, Virginia. Kepone escaped undetected from a manufacturing site for over 9 years and contaminated miles of the James (Nichols, 1990).

A well-documented case of the effects of point sources on sediment quality is the Newark Bay estuary in New Jersey, which encompasses the Passaic River, Hackensack River, Kill van Kull, and Arthur Kill. Wenning et al. (1994) examined sediment core samples from the lower Passaic River in New Jersey and concluded that the sediment is heavily contaminated with PCBs, PAHs, and metals from recent and historical municipal and industrial discharges from local and upstream sources. The authors identify industrial effluent, either directly discharged or released through combined sewer overflows, as the most likely primary source. Researchers have also measured high levels of dioxin in sediment in the estuary adjacent to an industrial site in Newark where chlorinated phenols had been produced (Bopp et al., 1991). In a recent study, researchers determined that the magnitude of current loading estimates for metals and organics from major sources, such as industrial and municipal discharges and combined sewer overflows, likely exceeds the capacity of the Newark Bay estuary to absorb and dilute the various waste streams (Crawford et al., 1995).

EPA has conducted an inventory and analysis of point source releases of sediment contaminants in the United States. This inventory includes examination of data from effluent monitoring required by discharge permits and chemical release estimates provided by industry under the community right-to-know provision of the Superfund Amendments and Reauthorization Act of 1986 (SARA). Permit monitoring data indicate that municipal sewage treatment plants and major industrial facilities discharge all chemical classes of sediment contaminants. Metals are monitored at the greatest number of facilities and released in the largest amounts. Mercury, PAHs, and other organics are also released from many facilities. PCBs and pesticides are less frequently monitored, and a relatively small number of records indicate positive detections. Industry-supplied release estimates provided under SARA indicate that manufacturing facilities transfer the majority of their sediment contaminants, primarily metals and other organics, to municipal sewage treatment plants. The analysis of these data addresses the potential to adversely affect

sediment quality, but does not indicate whether these discharges actively contribute to documented cases of sediment contamination.

Land Use Patterns and Sediment Contamination

The characteristics of local sediment contamination are usually related to the types of land use activities that take place or have taken place within the area that drains into the water body (the watershed). The previous section of this chapter provided numerous examples of these relationships from published studies. For this report, EPA examined the relationship between the extent of sediment contamination by chemical class and patterns of land use in the 96 APCs. EPA identified individual watersheds where land use appears to provide important information concerning the types of contaminants present, and summarized general trends that emerge by looking at the percent of urban and agricultural land areas in watersheds.

This analysis was based on a comparison of the extent of contamination by chemical class (described earlier in this chapter) within each watershed to the percent of land area developed for certain uses within the watershed. EPA used the Agency's modeling tool, Better Assessment Science Integrating Point and Nonpoint Sources (BASINS), for spatial analysis to quickly obtain land use data originally compiled by the U.S. Geological Survey (USGS) on a watershed basis. Although these land use data might be as much as 20 years old, the data compiled for the NSI have also been collected over the past 15 years. The original land use data are divided into 10 categories. EPA combined residential, commercial/industrial, and other urban land uses in the "total urban" land use category for this analysis. EPA also combined cropland and other agricultural land/rangeland in a "total agricultural" land use category. This allowed comparison of attributes such as the percent of stations with pesticide contamination and the percent total agricultural land use.

Several difficulties are associated with this approach to comparing land use to the evaluation of NSI sampling stations. First, the frequency and spatial extent of sampling data in the NSI vary by watershed. Second, the acreage of a land use activity is not indicative of the *intensity* of that use. For example, a small amount of land in a watershed might be devoted to an industrial activity that contributes a large amount of pollution. Most watersheds contain at least a small fraction of each

land use activity. There are also problems of scale. Localized problems in specific reaches might be caused by land use activity in the immediate vicinity of the reach rather than the overall land use in the watershed. Lastly, many individual pollutants and chemical classes are associated with multiple types of sources. Some classes of pollutants, like the highly persistent PCBs, have been cycled in the environment for many years and transported far from their original source. These chemicals would not be expected to be associated with any general land use category.

Table 4-2 lists each of the 96 APCs with the number of Tier 1 and Tier 2 stations by chemical class and the percent land use information. In general, EPA found that a diversified set of land uses yields a diversified set of pollutants. However, in some cases a preponderance of one land use type is associated with expected chemical classes of sediment contaminants. For example, the Lower Yakima watershed in Washington, an intensive fruit and vegetable growing region, is approximately 81 percent agricultural and only 2 percent urban. In this watershed, nearly 90 percent of the sampling stations were contaminated with pesticides, whereas no stations exhibited mercury contamination and less than 10 percent exhibited contamination from metals or PAHs. These percentages were substantially different from the average values presented in Figure 4-1. Similar findings were evident in other highly agricultural watersheds, such as the Tulare-Buena Vista Lakes in California.

In some cases, the absence of a particular land use in a watershed can provide clues about the source of in-place contaminants. Some watersheds, such as the Lower Mississippi-New Orleans in Louisiana and the Hackensack-Passaic in New Jersey, have very low agricultural land usage, yet a high percentage of contamination from pesticides. High levels of contaminants in recent sediment deposition may indicate upstream delivery of contaminants, whereas high levels in buried sediment may be indicative of pesticide manufacture/formulation or urban applications in the past. In the Coeur D'Alene watershed in Idaho, there is very little agricultural land use and almost no urban land use. In this watershed, where mining is a known source of contamination, over 90 percent of the stations exhibited metal contamination, whereas none indicated PAH or pesticide contamination. In other watersheds with very low percent urbanization, there was substantial contamination from all chemical classes except PAHs. This phenomenon was evident in several nonurbanized watersheds in the Southeast and upper Midwest, such as Pickwick Lake and Gunter'sville Lake. Further ex-

Table 4-2. Tier 1 and Tier 2 Station Classification by Chemical Class and Land Uses in Watersheds Containing Areas of Probable Concern for Sediment Contamination (APCs)

EPA Reg. Unit #	Name	Number of Stations With a Probability of Adverse Effects											Percent of Total Area in Each Watershed									
		Tier	Mercury	Other Metals	PCBs	Pesticides	PAHs	Other Chemicals*	All Stations	Total # of Stations	Residential	Commercial/Industrial	Other Urban	Cropland	Other Agricultural	Forestland	Bayes & Estuaries	Other Water	Other	Missing/Unknown		
1	01090001	Charles	1	146	68	35	8	11	1	195	708	25.43%	5.95%	4.56%	3.06%	0.04%	39.57%	7.82%	1.47%	6.23%		
1	01090004	Naragansett	2	216	486	54	50	50	0	402	48	13.74%	3.58%	4.61%	7.41%	0.86%	51.56%	9.96%	1.14%	0.88%		
1	01090002	Cape Cod	2	20	27	17	18	22	0	20	108	5.90%	0.81%	1.77%	1.84%	4.12%	22.90%	35.05%	1.37%	21.98%		
2	04120103	Buffalo-Eighteenmile	2	27	60	33	33	34	0	73	101	8.27%	3.54%	3.20%	42.85%	0.10%	30.94%	10.31%	0.43%	0.02%		
2	02030103	Hicksonack-Passaic	1	21	12	13	23	10	4	43	103	33.33%	7.24%	5.65%	2.62%	0.26%	38.99%	0.00%	1.33%	3.64%		
2	04130001	Oak Orchard-Twelvemile	2	10	20	4	8	4	2	39	86	2.25%	44.43%	1.25%	10.48%	3.29%	8.42%	26.77%	2.78%	0.04%		
2	02030104	Sandy Hook-States Island	2	30	61	15	20	12	13	46	100	30.58%	10.23%	7.70%	6.99%	0.49%	7.83%	13.66%	2.22%	13.03%		
2	04120104	Niagara	1	5	0	17	13	19	16	24	41	9.35%	32.02%	3.91%	31.59%	0.24%	17.47%	0.02%	0.92%	0.87%		
2	04150301	Upper St. Lawrence	2	16	29	9	11	9	16	16	31	1.51%	0.85%	1.29%	36.31%	0.75%	28.47%	0.06%	26.73%	3.82%		
2	02030105	Raritan	1	1	1	4	5	1	1	13	65	15.15%	4.87%	2.99%	25.86%	0.49%	26.55%	0.00%	2.65%	20.43%		
2	02040301	Mullica-Toms	2	11	39	25	27	4	3	37	42	8.54%	1.71%	1.18%	6.04%	0.52%	43.11%	7.97%	2.32%	7.86%		
2	02040105	Middle Delaware-Musconetong	2	10	24	10	11	15	4	22	48	5.49%	1.53%	1.26%	38.02%	0.16%	33.98%	0.00%	2.68%	16.22%		
2	02030202	Southern Long Island	1	3	19	13	20	2	0	26	43	23.38%	5.03%	5.06%	4.29%	0.74%	10.73%	19.75%	3.26%	25.88%		
2	02060003	Gunpowder-Patapsco	2	7	4	1	4	1	2	11	43	13.47%	5.10%	4.32%	40.80%	0.11%	26.70%	4.62%	4.11%	0.01%		
2	02040203	Schuylkill	2	6	19	4	21	7	4	7	29	9.17%	2.68%	2.78%	41.37%	0.26%	25.81%	0.00%	2.46%	14.82%		
3	05030101	Upper Ohio	1	0	1	11	0	0	2	12	44	13.08%	2.52%	2.18%	35.26%	0.34%	43.13%	0.00%	1.07%	0.00%		
3	02070004	Conococheague-Opequon	2	0	29	0	9	0	1	29	53	1.88%	0.98%	0.89%	50.58%	1.55%	43.24%	0.00%	0.51%	0.02%		
3	02040202	Lower Delaware	2	2	17	1	13	0	0	12	57	26.68%	13.51%	6.47%	21.76%	1.90%	18.45%	0.18%	1.17%	0.27%		
3	05030102	Shenango	2	7	23	20	33	2	0	29	15	3.93%	0.76%	2.20%	74.41%	0.02%	12.85%	0.00%	5.36%	0.02%		
3	04120101	Chautauqua-Connetquot	1	0	2	0	8	0	0	1	110	4.07%	1.13%	2.05%	38.07%	0.21%	21.58%	31.10%	0.18%	1.40%		
4	06010201	Watts Bar Lake	2	5	0	58	0	0	1	63	89	9.71%	1.84%	1.29%	27.72%	0.06%	52.32%	0.00%	5.20%	0.01%		
4	06010207	Lower Clinch	1	46	19	24	0	4	3	61	79	11.76%	1.74%	1.24%	24.98%	0.04%	56.28%	0.00%	2.16%	0.16%		
4	06030005	Pickwick Lake	2	11	33	0	7	14	20	14	69	1.93%	0.60%	0.33%	40.73%	0.07%	44.51%	0.00%	4.07%	6.41%		
4	06020001	Middle Tennessee-Chickamauga	1	14	1	16	1	26	7	47	94	8.14%	1.58%	1.19%	19.50%	0.04%	64.76%	0.00%	3.34%	0.00%		
4	05080103	Lower St. Johns	2	15	57	1	12	0	9	29	188	6.99%	1.71%	1.57%	9.03%	1.72%	51.60%	0.00%	25.04%	0.36%		

Table 4-2. (Continued)

EPA Cataloging Unit #	Name	Number of Stations With a Probability of Adverse Effects										Percent of Total Area in Each Watershed										
		Tier	Mercury	Other Metals	PCBs	Pesticides	PAHs	Other Chemicals*	All Chemicals*	Total # of Stations	Residential	Commercial/Industrial	Other Urban	Cropland	Other Agricultural	Forestland	Bays & Estuaries	Other Water	Other	Missing/Unknown		
4	06030001	06030001	1	7	1	15	3	0	0	0	0	25	92	0.97%	0.33%	0.25%	40.41%	0.05%	52.24%	0.00%	5.18%	0.05%
4	03130002	03130002	2	36	60	0	11	0	0	0	46	21	27	4.86%	0.77%	0.95%	15.41%	0.12%	75.59%	0.00%	0.98%	0.05%
4	03060106	03060106	1	11	11	19	3	2	6	20	2	20	36	3.75%	1.78%	0.81%	16.90%	0.18%	62.67%	0.00%	0.98%	0.00%
4	03140102	03140102	1	0	7	2	9	2	0	19	0	19	51	3.04%	4.94%	1.10%	3.03%	0.01%	61.80%	17.57%	3.14%	4.13%
4	06040005	06040005	2	14	32	9	11	15	0	23	0	23	30	1.25%	0.33%	0.26%	25.78%	0.00%	58.59%	0.00%	13.00%	0.03%
4	06040001	06040001	1	1	0	14	0	0	1	15	1	15	25	0.38%	0.12%	0.20%	28.06%	0.01%	65.47%	0.00%	3.01%	0.94%
4	06020002	06020002	1	1	0	12	0	0	2	13	0	13	33	2.65%	0.51%	0.58%	18.99%	0.11%	58.13%	0.00%	1.63%	15.63%
4	08010100	08010100	2	1	1	12	0	0	4	14	0	14	20	0.57%	0.88%	0.35%	49.87%	0.06%	21.07%	0.00%	25.08%	0.03%
4	06010104	06010104	1	3	1	10	0	0	2	12	0	12	15	4.73%	1.14%	0.45%	44.35%	0.01%	43.72%	0.00%	5.29%	0.00%
4	03040201	03040201	1	1	0	7	5	0	2	11	0	11	34	2.02%	0.55%	0.47%	32.03%	0.20%	54.90%	0.01%	9.43%	0.01%
4	03160205	03160205	2	14	38	6	16	21	0	43	0	43	81	4.22%	0.91%	0.97%	2.68%	0.43%	9.60%	18.20%	1.97%	60.70%
4	08030209	08030209	2	0	0	0	11	0	0	11	0	11	21	1.29%	0.57%	0.77%	74.35%	0.91%	18.66%	0.00%	3.34%	0.88%
4	03140107	03140107	1	8	0	1	0	1	1	10	1	10	38	8.04%	2.35%	1.12%	2.59%	0.16%	14.87%	8.08%	4.77%	1.61%
4	03060101	03060101	2	8	15	3	0	9	0	24	0	24	16	0.54%	0.02%	0.02%	0.12%	0.00%	13.24%	0.00%	0.58%	85.13%
5	04090004	04090004	1	42	21	74	42	53	38	85	17	85	115	42.87%	12.65%	8.99%	24.55%	0.18%	5.95%	0.78%	2.29%	1.74%
5	07120003	07120003	2	27	52	16	37	0	0	64	0	64	103	36.16%	19.12%	8.10%	20.63%	0.00%	4.45%	8.76%	1.14%	1.63%
5	07120004	07120004	2	12	4	54	11	0	1	61	1	61	110	21.71%	9.97%	6.61%	48.40%	0.31%	7.47%	0.00%	2.04%	3.48%
5	04040003	04040003	1	5	6	43	6	20	14	60	0	60	90	11.83%	5.78%	4.20%	66.30%	0.08%	6.64%	0.10%	4.68%	0.00%
5	04030204	04030204	1	21	3	41	8	5	5	49	5	49	51	8.94%	5.28%	2.88%	76.15%	0.04%	3.43%	0.11%	2.19%	0.00%
5	04040001	04040001	2	10	14	40	9	7	10	45	10	45	89	7.34%	6.16%	2.59%	37.11%	0.22%	12.87%	30.51%	2.12%	1.08%
5	04040002	04040002	2	5	4	28	3	1	1	34	3	34	72	12.02%	5.19%	4.10%	33.68%	0.04%	0.93%	43.58%	0.18%	0.29%
5	07140201	07140201	1	0	0	23	14	0	0	31	0	31	55	1.19%	0.39%	0.69%	90.79%	0.02%	5.83%	0.00%	1.05%	0.00%
5	07010206	07010206	2	4	8	6	38	0	0	24	0	24	35	21.99%	5.24%	5.12%	48.03%	0.03%	4.39%	0.00%	14.24%	0.95%
5	07140106	07140106	1	1	2	0	5	0	1	2	1	2	94	1.96%	0.91%	0.66%	70.37%	0.51%	20.43%	0.00%	3.60%	1.56%
5	07070003	07070003	2	2	1	0	20	0	2	20	0	20	22	1.05%	0.53%	0.55%	40.77%	0.05%	37.43%	0.06%	18.97%	0.64%

Table 4-2. (Continued)

EPA Cataloging Reg. Unit #	Name	Tier	Number of Stations With a Probability of Adverse Effects										Total # of Stations	Percent of Total Area in Each Watershed							Missing/Unknown
			Mercury	Other Metals	PCBs	Pesticides	PAHs	Other Chemicals*	Residential	Commercial/Industrial	Other Urban	Cropland		Other Agricultural	Forestland	Boys & Females	Other Water	Other			
5	04100002 Raisin	1	1	0	17	7	1	0	18	38	2.25%	1.00%	0.74%	87.13%	0.15%	5.46%	0.01%	2.90%	0.35%	0.00%	
5	04050001 St. Joseph	2	2	7	17	13	2	6	19	32	3.08%	1.42%	1.02%	79.21%	1.25%	9.23%	0.03%	4.45%	0.31%	0.00%	
5	07040003 Buffalo-Whitewater	1	0	1	3	7	7	3	17	26	0.74%	0.29%	0.40%	54.93%	0.05%	37.00%	0.00%	6.50%	0.08%	0.00%	
5	04110001 Black-Rocky	2	1	2	0	6	0	0	3	59	11.18%	2.79%	4.40%	66.45%	0.20%	11.11%	3.20%	0.38%	0.29%	0.00%	
5	07120006 Upper Fox	1	0	0	15	0	0	0	15	60	10.36%	2.44%	2.38%	63.18%	0.61%	10.84%	0.00%	7.42%	2.77%	0.00%	
5	05120111 Middle Wabash-Busseron	2	12	37	14	27	0	0	40	33	2.49%	0.92%	1.02%	79.64%	0.09%	13.31%	0.00%	1.50%	1.03%	0.00%	
5	07140202 Middle Kaskaskia	1	7	7	0	9	0	0	15	38	1.21%	0.40%	0.60%	78.52%	0.09%	16.06%	0.00%	3.01%	0.10%	0.00%	
5	07040001 Rush-Vermillion	2	4	16	6	22	0	0	22	14	1.38%	0.59%	0.44%	80.68%	0.06%	9.43%	0.00%	7.07%	0.34%	0.00%	
5	05120109 Vermillion	1	8	2	3	0	0	0	1	28	3.92%	1.00%	0.73%	90.08%	0.10%	3.51%	0.00%	0.15%	0.50%	0.00%	
5	04030108 Menominee	2	2	19	1	26	0	0	16	21	0.55%	0.17%	0.29%	10.13%	0.01%	67.58%	0.01%	20.94%	0.31%	0.01%	
5	04090002 Lake St. Clair	1	5	4	5	0	2	1	12	19	18.44%	3.81%	2.35%	28.70%	0.00%	3.60%	38.06%	4.87%	0.17%	0.00%	
5	07140101 Cahokia-Jochim	2	4	1	11	2	0	5	18	56	10.64%	4.50%	4.32%	42.42%	0.11%	33.25%	0.00%	3.85%	0.92%	0.00%	
5	04100010 Cedar-Portage	1	3	0	3	3	3	3	13	56	1.85%	1.28%	1.44%	73.80%	0.07%	1.56%	17.41%	2.10%	0.49%	0.00%	
5	04100001 Ottawa-Stony	2	24	46	0	4	15	9	39	29	6.73%	2.43%	2.93%	75.57%	0.30%	6.19%	3.84%	1.12%	0.89%	0.00%	
5	07130001 Lower Illinois-Senachwine Lake	1	0	0	12	0	0	0	12	21	2.04%	1.04%	0.51%	82.55%	0.04%	8.96%	9.00%	4.04%	0.82%	0.00%	
5	04030102 Door-Kewaunee	2	6	12	9	15	0	0	10	20	0.77%	0.35%	0.46%	38.47%	0.87%	10.63%	42.55%	5.63%	0.25%	0.00%	
5	04060103 Manatee	1	0	8	0	6	2	0	5	14	0.45%	0.20%	0.30%	17.77%	0.14%	73.75%	0.00%	6.82%	0.57%	0.00%	
5	05040001 Tuscarawas	2	7	11	11	12	4	7	3	78	10.00%	1.64%	1.71%	53.74%	0.04%	30.05%	0.00%	0.97%	1.85%	0.00%	
5	07090006 Kishwaukee	1	0	0	10	0	0	0	10	34	2.25%	1.05%	0.99%	91.45%	0.38%	2.99%	0.00%	0.30%	0.58%	0.00%	
5	04100012 Huron-Vermillion	1	1	0	5	0	0	5	10	45	1.63%	0.54%	0.91%	85.38%	0.17%	6.86%	3.93%	0.27%	0.27%	0.04%	
5	04110003 Ahubula-Chagrin	2	21	45	3	0	17	5	35	31	18.31%	3.14%	5.37%	39.91%	0.06%	27.41%	4.86%	0.63%	0.30%	0.01%	
6	08080206 Lower Coteau	1	12	2	4	2	11	10	26	100	2.75%	2.01%	0.44%	30.87%	0.21%	4.37%	0.00%	54.19%	0.50%	4.67%	
6	08090100 Lower Mississippi-New Orleans	2	18	35	5	6	15	13	52	51	3.09%	2.26%	0.73%	1.70%	0.03%	1.54%	16.26%	39.49%	0.53%	34.37%	
6	11070209 Lower Neosho	2	11	48	30	40	34	1	34	20	0.34%	0.02%	0.05%	4.48%	0.01%	3.35%	0.00%	1.08%	0.02%	90.65%	
6	08040207 Lower Onatchia	1	0	0	1	11	0	1	12	12	3.38%	0.53%	0.51%	30.43%	0.12%	52.72%	0.00%	8.96%	3.36%	0.00%	

Table 4-2. (Continued)

EPA Cataloging Reg. Unit #	Name	Number of Stations With a Probability of Adverse Effects										Percent of Total Area in Each Watershed									
		Tier	Mercury	Other Metals	PCBs	Pesticides	PAHs	Other Chemicals ^a	All Chemicals ^a	Total # of Stations	Residential	Commercial/Industrial	Other Urban	Cropland	Other Agricultural	Forestland	Estuaries	Other Water	Other	Missing/Unknown	
6	12040104	1	0	1	9	3	1	3	1	3	10	36	23.31%	7.07%	6.32%	45.96%	0.06%	13.38%	0.04%	0.86%	
		2	14	26	15	14	11	3	23	23	23										
7	10270104	1	0	1	11	0	0	0	1	12	29		3.70%	1.82%	1.83%	82.75%	0.91%	7.67%	0.00%	0.40%	
		2	1	14	0	22	1	3	15	15										0.00%	
7	11070207	1	0	0	8	0	1	2	10	41			1.84%	0.67%	0.79%	80.42%	0.12%	14.27%	0.00%	1.70%	
		2	1	29	1	7	0	1	25	27			5.40%	2.53%	1.53%	68.60%	0.18%	9.58%	0.00%	0.54%	
7	07080101	1	1	7	0	18	1	2	5				11.02%	4.09%	2.72%	6.92%	54.83%	9.62%	1.36%	1.98%	
		2	1	7	0	18	1	2	5	107			17.03%	7.90%	2.86%	1.18%	20.81%	0.68%	0.41%	0.96%	
9	18070304	1	18	4	33	13	7	2	53	132			41.18%	22.80%	4.68%	4.98%	0.12%	0.00%	0.75%	1.27%	
		2	26	93	45	47	39	4	51	442			20.29%	9.69%	9.13%	6.07%	23.27%	27.93%	1.58%	0.66%	
9	18070104	1	15	6	22	66	4	1	79	339			19.51%	13.49%	6.60%	18.96%	28.16%	0.25%	1.09%	3.33%	
		2	33	94	34	22	18	3	31	64			12.06%	7.21%	3.48%	4.43%	27.36%	28.64%	14.20%	0.65%	
9	18070201	1	5	0	8	23	2	32	63	37			38.26%	13.78%	6.51%	1.31%	31.59%	6.65%	0.02%	1.46%	
		2	38	211	142	288	30	182	339	20			1.76%	1.53%	0.70%	55.36%	38.72%	0.90%	0.00%	0.63%	
9	18030003	1	14	8	0	0	0	0	18	24			0.00%	0.08%	0.01%	0.00%	2.59%	0.00%	0.02%	0.18%	
		2	8	12	1	1	1	0	6	25			3.18%	1.26%	1.22%	4.37%	60.80%	5.39%	0.03%	1.49%	
9	18070204	1	10	0	1	11	0	2	24	108			19.51%	13.49%	6.60%	18.96%	28.16%	0.25%	1.09%	3.33%	
		2	13	62	19	48	8	25	68	64			12.06%	7.21%	3.48%	4.43%	27.36%	28.64%	14.20%	0.65%	
9	18030004	1	10	9	1	0	5	0	19	37			38.26%	13.78%	6.51%	1.31%	31.59%	6.65%	0.02%	1.46%	
		2	33	41	18	19	21	0	37	20			1.76%	1.53%	0.70%	55.36%	38.72%	0.90%	0.00%	0.63%	
9	18070105	1	4	0	2	8	3	0	14	37			0.00%	0.08%	0.01%	0.00%	2.59%	0.00%	0.02%	0.18%	
		2	16	33	4	10	5	1	19	25			3.18%	1.26%	1.22%	4.37%	60.80%	5.39%	0.03%	1.49%	
9	18030012	1	0	0	1	10	1	1	10	20			1.76%	1.53%	0.70%	55.36%	38.72%	0.90%	0.00%	0.63%	
		2	1	5	4	5	0	0	5	32			0.00%	0.08%	0.01%	0.00%	2.59%	0.00%	0.02%	0.18%	
9	18070107	1	7	2	2	10	0	0	14	25			0.00%	0.08%	0.01%	0.00%	2.59%	0.00%	0.02%	0.18%	
		2	3	22	6	3	4	3	10	32			3.18%	1.26%	1.22%	4.37%	60.80%	5.39%	0.03%	1.49%	
9	18070301	1	5	2	0	5	0	0	10	32			3.18%	1.26%	1.22%	4.37%	60.80%	5.39%	0.03%	1.49%	
		2	7	29	9	7	2	0	22	1383			12.36%	2.12%	2.05%	3.75%	0.32%	41.35%	34.95%	0.48%	
10	17110019	1	98	52	146	37	296	32	418	127			12.99%	2.97%	4.23%	6.82%	0.55%	70.85%	0.00%	0.63%	
		2	449	1116	317	106	490	317	851	263			4.22%	0.75%	1.22%	10.95%	0.46%	28.13%	51.38%	0.20%	
10	17110013	1	0	3	34	3	12	6	48	47			1.13%	0.52%	0.26%	25.97%	55.06%	15.65%	0.00%	0.17%	
		2	27	107	10	17	58	23	69	76			31.21%	6.41%	4.69%	13.32%	0.97%	39.03%	0.00%	0.00%	
10	17110002	1	16	1	1	4	12	4	32	19			5.85%	0.55%	0.79%	3.78%	4.44%	81.43%	0.00%	2.47%	
		2	51	180	15	34	73	28	168	23			0.73%	0.13%	0.42%	12.68%	0.65%	75.10%	0.00%	0.44%	
10	17030003	1	0	0	5	19	0	1	23	23			0.00%	0.00%	0.00%	0.00%	0.00%	0.00%	0.00%	0.00%	
		2	0	4	0	23	1	10	19	19			0.00%	0.00%	0.00%	0.00%	0.00%	0.00%	0.00%	0.00%	
10	17090012	1	1	0	13	10	5	4	21	19			5.85%	0.55%	0.79%	3.78%	4.44%	81.43%	0.00%	2.47%	
		2	12	51	24	18	11	15	51	12			0.00%	0.00%	0.00%	0.00%	0.00%	0.00%	0.00%	0.00%	
10	17110014	1	0	3	1	0	8	1	12	19			0.00%	0.00%	0.00%	0.00%	0.00%	0.00%	0.00%	0.00%	
		2	0	8	6	1	9	6	6	23			0.00%	0.00%	0.00%	0.00%	0.00%	0.00%	0.00%	0.00%	
10	17010303	1	1	8	2	0	0	0	10	23			0.00%	0.00%	0.00%	0.00%	0.00%	0.00%	0.00%	0.00%	
		2	1	13	0	0	0	0	13	13			0.00%	0.00%	0.00%	0.00%	0.00%	0.00%	0.00%	0.00%	

^aBecause of the numerous chemicals monitored at each station, the total in this column is not equal to the sum of the numbers in the columns for the different chemical classes.
^bAdapted from USGS land use and land cover classification system for use with remote sensor data.

amination of percent agricultural and urban land use revealed some general trends that are illustrated by these examples.

A high percentage of agricultural land use in a watershed tended to correspond with a markedly higher percent contamination from pesticides and lower percent contamination from metals, mercury, and PAHs. This phenomenon is presented graphically in Figure 4-2 and in tabular form on Table 4-3. For this analysis, EPA grouped watersheds into quartiles based on percent total agricultural land use and calculated the average percent of sampling stations with contamination by chemical class. Some general trends that would be expected were clearly evident. In watersheds with greater than 75 percent of the land devoted to agriculture, pesticide contamination jumped from under 40 percent of all stations to 64 percent. In contrast, metal, mercury, and PAH contamination all steadily decreased, with all three classes exhibiting a percent contamination in the over 75 percent agriculture group at least 10 percentage points under the overall average for each class. PCBs and other organics did not exhibit any trend and never varied more than 5 percentage points from the overall average.

In contrast, increasingly higher percentages of urban land use in watersheds correlated with steadily increasing contamination from most chemical classes. Figure 4-3 and Table 4-4 present the results of a trend analysis for total urban land use. For this analysis, EPA placed watersheds into groups of under 5 percent urban area, 5 to 10 percent urban area, 10 to 20 percent urban area, and greater than 20 percent urban area to best illustrate trends. The percent PAH and metal contamination were both 10 percentage points under the overall average for the least urbanized watershed group, then rose sharply as the proportion of urban area crossed the 5 percent threshold. The extent of metal contamination rose to an average of 71 percent, more than 10 percentage points above the overall average of 59 percent, in

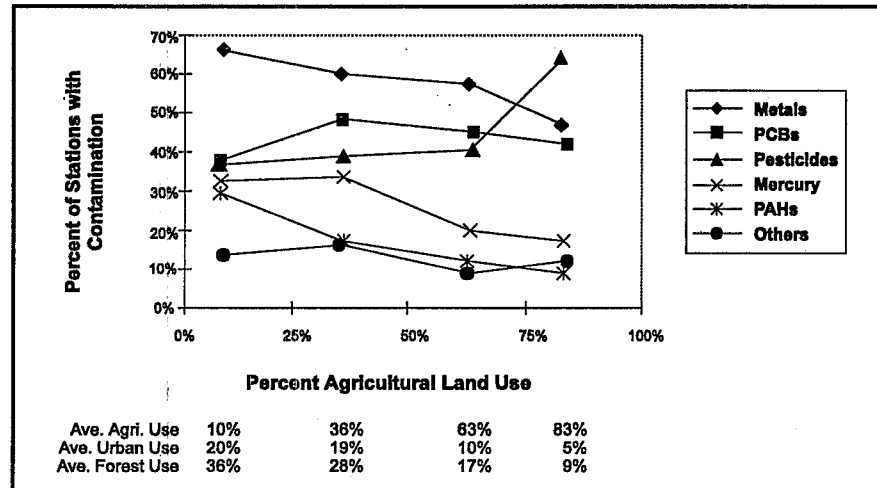

Figure 4-2. Percent Tier 1 and Tier 2 Stations vs. Agricultural Land Use in APCs.

Table 4-3. Comparison of Percent Agricultural Land Use in Watersheds Containing APCs to Percent of Tier 1 and Tier 2 Stations by Chemical Class

	Percent Total Agricultural Land Area				Overall Average
	<25%	25-50%	50-75%	>75%	
Average Percent Agricultural Land Area in Group	10%	36%	63%	83%	39%
Number of Watersheds in Group	32	34	13	17	
Metals	66%	60%	58%	47%	59%
PCBs	38%	48%	45%	42%	43%
Pesticides	37%	39%	40%	64%	43%
Mercury	32%	34%	20%	18%	29%
PAHs	30%	17%	12%	9%	19%
Others	13%	16%	9%	12%	14%

watersheds with more than 20 percent total urban land use. Mercury contamination rose steadily and reached a peak of 40 percent in the most heavily urbanized watersheds. The mercury and PAH trends perhaps illustrate the effect of atmospheric deposition from local urban sources. Contamination from other organics also rose steadily, but never varied more than 6 percentage points from the overall average. Pesticide contamination initially decreased as percent urbanization increased, but it rose more than 10 percentage points from the 10 to 20 percent urban group to the over 20 percent urban group. As mentioned previously, this may reflect upstream delivery of contaminants, pesticide manufacture or formulation, or urban applications in the past. As was the case with the agriculture analysis, the average percent PCB contamination for the urban groups showed no trend and never varied substantially from the overall average.

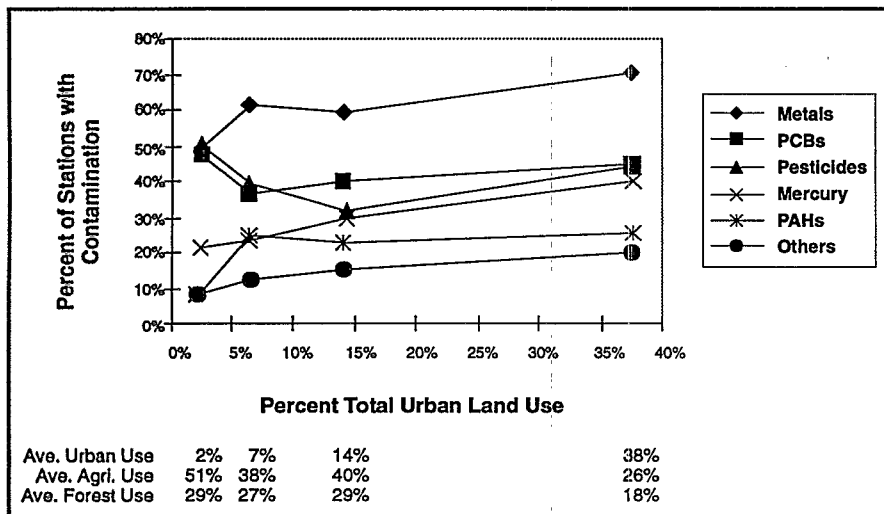

Figure 4-3. Percent Tier 1 and Tier 2 Stations vs. Urban Land Use in APCs.

Table 4-4. Comparison of Percent Urban Land Use in Watersheds Containing APCs to Percent of Tier 1 and Tier 2 Stations by Chemical Class

	Percent Total Urban Land Area				Overall Average
	<5%	5-10%	10-20%	>20%	
Average Percent Urban Land Area in Group	2%	7%	14%	38%	16%
Number of Watersheds in Group	32	18	19	27	
Metals	49%	61%	59%	71%	59%
PCBs	47%	37%	40%	45%	43%
Pesticides	50%	39%	32%	44%	43%
Mercury	21%	24%	30%	40%	29%
PAHs	9%	25%	23%	25%	19%
Others	8%	12%	15%	20%	14%

EPA's Point and Nonpoint Source Sediment Contaminant Inventories

As part of the National Sediment Inventory (NSI) and mandate under the Water Resources Development Act (WRDA) of 1992, EPA is conducting inventories of point and nonpoint sources of sediment contaminants.

The objective of the point source assessment component of the NSI is to compile available data regarding the purposeful discharge of sediment contaminants from industrial facilities and municipal sewage treatment plants and to determine the potential to adversely affect sediment quality by chemical class, watershed, and industrial category. EPA has produced the *National Sediment Contaminant Point Source Inventory*

based on 1994 permit monitoring records in EPA's Permit Compliance System (PCS) and chemical release estimates in the 1993 Toxic Release Inventory (TRI). The report presents a screening analysis to identify probable point source contributors of sediment pollutants based on release amount, chemical toxicity, and inherent physical/chemical properties of the contaminant. The report serves as Volume 3 of the complete report to Congress on the incidence and severity of sediment contamination in surface waters of the United States. As previously stated, discharge limits for point sources are not necessarily protective of downstream sediment quality. The Agency believes an effective source control strategy should focus on areas at greatest risk on a watershed scale. The report identifies 29 watersheds among the 96 APCs where the potential for point source contribution to sediment contamination is the greatest.

The objective of the nonpoint source assessment component of the NSI is to prepare a nationwide assessment of annual nonpoint source contributions of selected sediment contaminants on a watershed basis. Given the number and diversity of nonpoint sources, the Agency is focusing its initial efforts on four major categories: harvested croplands, urban areas, atmospheric deposition, and inactive and abandoned mine sites (where information is available). Although these nonpoint sources do not constitute the full range of sediment contaminant sources, they are frequently cited in the scientific literature as significant sources of mercury, PCBs, PAHs, metals, pesticides, and other organic compounds.

The nonpoint source assessment is intended to be a screening-level study that begins to correlate contaminated sediment locations with suspected sources of these contaminants. As part of this assessment, EPA is compiling data from the Bureau of the Census, the U.S.

Department of Agriculture, the U.S. Department of the Interior's U.S. Geological Survey and Bureau of Mines, and others. EPA will compile information and data concerning these nonpoint source activities to identify watersheds for further investigation and assessment.

Given the breadth of nonpoint sources, EPA anticipates that the process of conducting future assessments

will be iterative. Additional nonpoint sources will be added to the inventory to discriminate more fully between contaminant types and known sources and to characterize their proximity to known or suspected contaminated sediment sites. This iterative process will allow EPA to identify regions of the country where nonpoint sources are known to exist, but data on sediment quality are either limited or lacking.

Chapter 5

Conclusions and Discussion

The National Sediment Inventory (NSI) is EPA's largest compilation of sediment chemistry data and related biological data. It includes approximately 2 million records for more than 21,000 monitoring stations across the country. EPA's evaluation of the NSI data was the most geographically extensive investigation of sediment contamination ever performed in the United States. The evaluation was based on procedures to address the probability of adverse effects to aquatic life and human health.

The characteristics of the NSI data, as well as the degree of certainty afforded by available assessment tools, allow neither an absolute determination of adverse effects on human health or the environment at any location, nor a determination of the areal extent of contamination on a national scale. However, the evaluation results strongly suggest that sediment contamination may be significant enough to pose potential risks to aquatic life and human health in some locations. The evaluation methodology was designed for the purpose of a screening-level assessment of sediment quality; further evaluation would be required to confirm that sediment contamination poses actual risks to aquatic life or human health for any given site or watershed.

Based on the number and percentage of sampling stations containing contaminated sediment within watershed boundaries, EPA identified a number of watersheds containing areas of probable concern for sediment contamination (APCs) where additional studies may be needed to draw conclusions regarding adverse effects and the need for actions to reduce risks. Although the APCs were selected by means of a screening exercise, EPA believes that they represent the highest priority for further ecotoxicological assessments, risk analysis, temporal and spatial trend assessment, contaminant source evaluation, and management action because of the preponderance of evidence in these areas. Although the procedure for classifying APCs using multiple sampling stations was intended to minimize the probability of making an erroneous classification, further evaluation of conditions in watersheds containing APCs is necessary because the same mitigating factors that might reduce the probability of associated adverse effects at one sam-

pling station may also affect neighboring sampling stations.

EPA chose the watershed as the unit of spatial analysis because many state and federal water and sediment quality management programs, as well as data acquisition efforts, are centered around this unit. This choice reflects the growing recognition that activities taking place in one part of a watershed can greatly affect other parts of the watershed, and that management efficiencies are achieved when viewing the watershed holistically. At the same time, the Agency recognizes that contamination in some reaches in a watershed does not necessarily indicate that the entire watershed is affected.

Watershed management is a vital component of community-based environmental protection. The Agency and its state and federal partners can address sediment contamination problems through watershed management approaches. Watershed management programs focus on hydrologically defined drainage basins rather than areas defined by political boundaries. These programs recognize that conditions of land areas and activities within the watershed affect the water resource. Local management, stakeholder involvement, and holistic assessments of water quality are characteristics of the watershed approach. The National Estuary Program is one example of the watershed approach that has led to specific actions to address contaminated sediment problems. Specifically, the Narragansett (RI) Bay, Long Island Sound, New York/New Jersey Harbor, and San Francisco Bay Estuary Programs have all recommended actions to reduce sources of toxic contaminants to sediment. Numerous other examples of watershed management programs are summarized in *The Watershed Approach: 1993/94 Activity Report* (USEPA, 1994g) and *A Phase I Inventory of Current EPA Efforts to Protect Ecosystems* (USEPA, 1995b).

This chapter presents some general conclusions about the extent of sediment contamination in the United States and sources of sediment contaminants. It also includes comparisons to other national studies that address the extent of sediment contamination and to a national survey of state-issued fish consumption advisories. In addition, this chapter presents the results of an analy-

sis of the sensitivity of parameters used to evaluate potential human health effects from exposure to PCBs and mercury, which was performed to show how the use of different screening values affect the results. The chapter concludes with a discussion of the strengths and limitations of the NSI data and evaluation method.

It is important to understand both the strengths and limitations of this analysis to appropriately interpret and use the information contained in this report. The limitations do not prevent intended uses, and future reports to Congress on sediment quality will contain less uncertainty. To ensure that future reports to Congress accurately reflect current knowledge concerning the conditions of the Nation's sediment as our knowledge and application of science evolves, the NSI will develop into a periodically updated, centralized assemblage of sediment quality measurements and assessment techniques.

Extent of Sediment Contamination

Based on the evaluation, sediment contamination exists at levels where associated adverse effects are probable (Tier 1) in some locations within each region and state of the country. The water bodies affected include streams, lakes, harbors, nearshore areas, and oceans. A number of specific areas in the United States had large numbers of sampling stations where associated adverse effects are probable. Puget Sound, Boston Harbor, the Detroit River, San Diego Bay, and portions of the Tennessee River were among those locations. Several U.S. harbors (e.g., Boston Harbor, Puget Sound, Los Angeles, Chicago, Detroit) appear to have some of the most severely contaminated sediments in the country. This finding is not surprising since major U.S. harbors have been affected throughout the years by large volumes of boat traffic, contaminant loadings from upstream sources, and many local point and nonpoint sources.

Thousands of other water bodies in hundreds of watersheds throughout the country contain sampling stations classified as Tier 1. Many of these sampling stations may represent isolated "hot spots" rather than widespread sediment contamination, although insufficient data were available in the NSI to make such a determination. EPA's River Reach File 1 (RF1) delineates the Nation's rivers and waterways into segments, or reaches, of approximately 1 to 10 miles in length. Based on RF1, approximately 11 percent of all river reaches in the United States contained NSI sampling stations. More than 5,000 sampling stations in approximately 2,400 river reaches across the country (4 percent of all reaches) were classified as Tier 1. Another 10,000 sampling stations were

classified as Tier 2. In total, over 5,000 river reaches in the United States—approximately 8 percent of all river reaches—include at least one Tier 1 or Tier 2 station.

EPA cannot determine the areal extent or number of river miles of contaminated sediment in the United States because the NSI does not provide complete coverage for the entire nation, sampling locations are largely based on a nonrandom sampling design, and sediment quality can vary greatly within very short distances.

Most of the NSI data were compiled from nonrandom monitoring programs. Such monitoring programs focus sampling efforts on areas where contamination is known or suspected to occur. As a result, assuming all other factors are the same, the frequency of Tier 1 or Tier 2 classification based on the NSI data evaluation is probably greater than that which would result from purely random sampling. Swartz et al. (1995) demonstrated the effects of nonrandom sampling design on the frequency of detecting contaminated sampling stations. They compared the percent of sediment sampling stations that exceeded PAH screening effects levels (ERL, SQC, AET) based on random sampling station selection (Virginian Province EMAP stations) to the percent of sampling stations that exceeded those levels based on sampling station selection on the basis of known PAH contamination (such as creosote-contaminated Eagle Harbor, Washington). They found that the frequency of exceeding a sediment chemistry screening value in sampling stations known to be contaminated was 5 to 10 times greater than that for randomly selected sampling stations.

The percentage of all NSI sampling stations where associated adverse effects are "probable" or "possible but expected infrequently" (i.e., 26 percent in Tier 1 and 49 percent in Tier 2) does not represent the overall condition of sediment across the country: the overall extent of contaminated sediment is much less, as is the percentage of sampling stations where contamination is expected to actually exert adverse effects. For example, a reasonable estimate of the national extent of contamination leading to adverse effects to aquatic life is between 6 and 12 percent of sediment underlying surface waters. This is primarily because the majority of sampling stations in the NSI are located in known or suspected areas of sediment contamination (i.e., sampling stations were not randomly selected). However, some individual data sets that are included in the NSI, as well as the results of independent investigations conducted by other researchers, can be applied to represent the areal extent of sediment contamination in their respective study areas. EPA's EMAP data collection effort featured a probabilistic, or random, sampling design. In the Virginian and Louisianian EMAP

Provinces, located on the Mid-Atlantic and Gulf coasts respectively, 104 of 678 (15.3 percent) of sediment samples were toxic to amphipods. With a 5 percent false positive rate (statistical $\alpha=0.05$), EMAP toxicity data suggest that about 10 percent of marine and estuarine sites are sufficiently contaminated to cause lethality to benthic organisms (Richard Swartz, personal communication, December 27, 1996). In another recent study, Long et al. (1996) examined amphipod survival in test sediment collected from 1,176 locations in 22 estuarine areas throughout the nation. These authors concluded that the areal extent of toxic sediment comprised approximately 11 percent of the combined study area.

To apply the NSI evaluation to estimate the areal extent of toxic sediment in the United States, three factors must be accounted for: (1) most of the NSI data were generated from sampling targeted toward areas of known or suspected contamination, (2) sediment chemistry screening values only identify sediment associated with a *probability* of toxicity, and (3) toxicity is demonstrated at some sampling stations where sediment chemistry screening values are not exceeded. The latter condition could be a result of false positives (i.e., laboratory toxicity that would not be present in the field), toxic chemicals present in the field but not measured or evaluated, or toxicity that correlative screening values do not predict (e.g., by definition 10 percent of toxic samples in the "effects distribution" lie below the ERL).

Using information from available data and published studies, the effects of each of the above factors can be quantified. Swartz et al. (1995) suggest that exceeding a sediment chemistry screening value at sites of known or suspected contamination is 5 to 10 times more likely than at sites where sediment is randomly sampled. However, comparison of Tier 1 classification for Virginian and Louisiana EMAP data to the entire NSI data base suggests that the mix of sampling strategies in the NSI data base as a whole results in screening value exceedance at 2 to 4 times as many sampling stations than purely random sampling. Long et al., (in press), as well as a comparison of matched sediment chemistry and toxicity data within the NSI, suggest that approximately 40 percent of Tier 1 sampling stations, and 20 percent of Tier 2 sampling stations, would exhibit significant lethality to bottom dwelling aquatic organism. Both data sets also suggest that significant lethality occurs at approximately 10 percent of Tier 3 stations, where no screening value is exceeded. Alternatively, one could assume that significant laboratory toxicity at randomly sampled locations classified as Tier 3 only represents "false positives", and therefore that no toxicity occurs at Tier 3 sampling stations classified from random sampling.

In the NSI evaluation, 3,283 and 9,688 of the 17,884 sampling stations with sediment chemistry data available were classified as Tier 1 and Tier 2, respectively, for risk to bottom dwelling aquatic organisms. Using a 40 percent probability of lethality at Tier 1 and a 20 percent probability of lethality at Tier 2, and further assuming 10 times less frequent Tier 1 and Tier 2 classification (upper end of range from Swartz et al., 1995) in a random sample and no lethality at Tier 3 sampling stations, the estimated extent of sediment contamination in the United States associated with lethality to bottom dwelling aquatic organisms is 2 percent. At the other extreme, assuming 2 times less frequent Tier 1 and Tier 2 classification (lower end of range from EMAP/NSI comparisons) in a random sample and a 10 percent probability of lethality at all resulting Tier 3 sampling stations (11,399; including the additional sampling stations previously classified as Tier 1 and Tier 2 before adjusting for random sampling), the estimated extent of sediment contamination associated with lethality to bottom dwelling aquatic organisms is 15 percent. Avoiding either extreme, assuming 2 to 5 times less frequent Tier 1 and Tier 2 classification in a random sample and a 10 percent probability of lethality for only the original Tier 3 sampling stations (4,913; prior to adjusting for random sampling), the range narrows to 6 to 12 percent—about 1,000 to 2,000 toxic sampling stations out of approximately 18,000. This range encompasses the areal extent point estimates from EMAP toxicity data and Long et al. (1996). EPA believes these are reasonable estimates of the extent of sediment contamination across the United States.

The results of the NSI data evaluation must be interpreted in the context of data availability. Many states and EPA Regions appear to have a much greater incidence of sediment contamination than others. To some degree, this appearance reflects the relative abundance of readily available electronic data, not necessarily the relative incidence of sediment contamination. For example, 182 of the 920 river reaches in Illinois contain a Tier 1 sampling station, whereas only 9 of the 5,490 reaches in Montana contain a Tier 1 sampling station. However, the NSI includes sampling station data for over 50 percent of the river reaches in Illinois but less than 1 percent of the river reaches in Montana. Therefore, although the absolute number of Tier 1 and Tier 2 stations in each state is important, relative comparisons of the incidence of sediment contamination between states is not possible because the extent of sampling and data availability vary widely.

For a number of reasons, some potentially contaminated sediment sites were missed in this evaluation. The most obvious reason is that the NSI does not include all

sediment quality data that have ever been collected. For example, the NSI does not include many EPA Superfund Program data and therefore sampling stations in the vicinity of hazardous waste sites might not have been included in the NSI evaluation. Additional data sets will be added to the NSI for future evaluations to provide better national coverage. In addition, some data in the NSI were not evaluated because of questions concerning data quality or because no locational information (latitude and longitude) was available.

Sources of Sediment Contamination

Some of the most significant sources of persistent and toxic chemicals have been eliminated or reduced as the result of environmental controls put into place during the past 10 to 20 years. For example, the commercial use of PCBs and the pesticides DDT and chlordane has been restricted or banned in the United States. In addition, effluent controls on industrial and municipal point source discharges and best management practices for the control of nonpoint sources have greatly reduced contaminant loadings to many of our rivers and streams.

The results of better controls over releases of sediment contaminants are evident from studies such as that conducted by Swartz et al. (1991) on the Palos Verdes Shelf. These researchers examined sediment cores collected at two sites on the Palos Verdes Shelf near the Los Angeles County Sanitation District's municipal wastewater outfalls, and at two reference sites in Santa Monica. They found that the vertical distribution of sediment toxicity near the outfalls was significantly correlated with profiles of total organic carbon and sediment chemical contamination. Dating of core horizons showed that sediment toxicity also was significantly correlated with historical records of the mass emission rate of suspended solids from the outfalls. The vertical profiles showed that the toxicity of surficial sediments increased after the initiation of the discharge in the 1950s, remained relatively high until the early 1970s, and then decreased after the implementation of source controls and improved effluent treatment (Swartz et al., 1991).

Based on the NSI data evaluation, metals and persistent organic chemicals are the contaminants most often associated with sediment contamination. Despite recent progress in controlling sediment contaminant releases to the environment, active sources of these contaminants still exist. These include nonpoint source loadings such as surface water runoff and atmospheric deposition, point source loadings, and resuspension of in-place sediment contaminants from historical sources.

Some correlations between land use and sediment contamination caused by specific classes of chemicals were identified in Chapter 4. Agricultural land use was correlated with the extent of sediment contaminated with organochlorine pesticides in APC watersheds, especially those with more than 75 percent of land area devoted to crop production or rangeland. In contrast, the extent of sediment contaminated with PAHs, mercury, and other metals in APC watersheds correlated with the extent of urban land use. Land use did not appear to be associated with the extent of PCB contamination.

Comparison of NSI Evaluation Results to Results of Previous Sediment Contamination Studies

The results of this study are consistent with the findings of other national assessments of sediment contamination. For example, in EPA's 1992 *National Water Quality Inventory* report, 27 states identified 770 known contaminated sediment sites (USEPA, 1994e). The identified "sites" probably best correlate to river reaches from this analysis in terms of areal extent. The NSI evaluation identified approximately 2,400 river reaches in 50 states that contain a Tier 1 sampling station. In the *National Water Quality Inventory* report, the states frequently listed metals (e.g., mercury, cadmium, and zinc), PCBs, DDT (and its by-products), chlordane, and priority organic chemicals as the cause of sediment contamination. They identified industrial and municipal discharges (past and present), landfills, resource extraction, abandoned hazardous waste disposal sites, and combined sewer overflows as the most important sources of sediment contamination.

In a 1987 overview of sediment contamination (which was based on a limited amount of national data), EPA estimated that hundreds of sites located in all regions of the United States have in-place sediment contaminants at concentrations of concern (USEPA, 1987). The study identified harbor areas, both freshwater and marine, as some of the most severely impacted areas in the country. The study identified municipal and industrial point source discharges, urban and agricultural runoff, combined sewer overflows, spills, mine drainage, and atmospheric deposition as frequently cited sources of sediment contamination.

In 1994, the National Oceanic and Atmospheric Administration (NOAA) released its *Inventory of Chemical Concentrations in Coastal and Estuarine Sediments* (NOAA, 1994). This study categorized 2,800 coastal sites as either "high" or "hot" based on the contaminant concentrations found at the sampling locations. NOAA did

not use risk-based screening values for its analysis. Using the National Status and Trends Mussel Watch data set, "high" values were defined as the mean concentration for a specific chemical plus one standard deviation. High values corresponded to about the 85th percentile of contaminant concentration. "Hot" concentrations were defined as those exceeding five times the "high" values. Most of the "hot" sites were in locations with high ship traffic, industrial activity, and relatively poor flushing, such as harbors, canals, and intracoastal waterways (NOAA, 1994). Mercury and cadmium exceeded the NOAA "hot" thresholds at a greater percentage of sites where they were measured (about 7 percent each) than other sediment contaminants.

Comparison of NSI Evaluation Results to Fish Consumption Advisories

EPA recently published a National Listing of Fish Consumption Advisories issued by state governments. As of 1994, 1,532 fish consumption advisories were in place in 46 states. (Each advisory might apply to several water body segments, or reaches, as defined in this study.) Mercury was the contaminant most often associated with fish consumption advisories; 1,119 water bodies had advisories that included mercury. States also issued a large number of advisories because of high levels of chlordane, PCBs, and dioxins in fish tissue.

A direct comparison of the fish advisory contaminants and NSI contaminants is not possible because states often issue advisories for groups of chemicals. Nevertheless, five of the top six contaminants associated with fish advisories (PCBs, DDT, dieldrin, chlordane, and dioxins) are also among the contaminants most often responsible for the Tier 1 classification of water bodies based on potential human health effects (Table 5-1). As illustrated in Figure 5-1, many sampling stations categorized as Tier 1 or Tier 2 for

human health effects are located in water bodies for which fish consumption advisories have been issued for the chemical(s) responsible for the Tier 1 or Tier 2 categorization. Tier 1 and Tier 2 stations are located predominantly where data have been collected and compiled for the NSI, whereas fish consumption advisories are located in states with active fish advisory programs. Unlike the NSI data evaluation, which is applied consistently to available data, risk assessment methods used by states may vary.

Although there is good agreement for other chemicals, mercury is notably absent from the Tier 1 category in Table 5-1. Using the NSI evaluation methodology, mercury cannot place a sampling stations in Tier 1 for potential human health effects. For chemicals other than PCBs and dioxins, sediment chemistry and fish tissue data must both indicate human health risk for Tier 1 assignment.

Table 5-1. Comparison of Contaminants Most Often Associated With Fish Consumption Advisories and Those Which Most Often Cause Stations to Be Placed in Tier 1 or Tier 2 Based on the NSI Data Evaluation

Chemical ^a	# of Water Bodies with Fish Advisories ^c	Number of River Reaches That Include at Least One Tier 1 or Tier 2 Station Based on the NSI Data Evaluation of Human Health Fish Consumption Advisories Parameters ^d		
		Tier 1	Tier 2 ^e	Total
Mercury	1,119	0	89	89
PCBs	387	1,498	732	2,230
Chlordane	114	11	1,026	1,037
Dioxins	53	242	8	250
DDT and metabolites	28	19	656	675
Dieldrin	15	9	1,296	1,305
Selenium	12	0	4	4
Mirex	10	0	15	15
PAHs	5	0	529	529
Toxaphene	4	0	183	183
Hexachlorobenzene	3	0	53	53
Lead	2	0	259	259
Hexachlorobutadiene	2	0	6	6
Creosote ^b	2	-	-	-
Chromium	1	0	6	6
Copper	1	0	4	4
Zinc	1	0	14	14

^aOther chemical groups responsible for fish consumption advisories (i.e., pesticides [24 water bodies], "multiple" [4 water bodies], "not specified" [4 water bodies], and metals [6 water bodies]) could not be directly compared to NSI chemicals.

^bNo reference values were available for creosote; therefore, it was not evaluated in the NSI data evaluation.

^cDoes not include statewide advisories

Mercury: New York, New Jersey, Maine, Massachusetts, Michigan, coastal Florida

Chlordane: Missouri

PCBs: New York

Dioxin: coastal Maine

^dA water body can be composed of numerous river reaches.

^eRiver reaches that include at least one Tier 2 sampling station but no Tier 1 sampling stations.

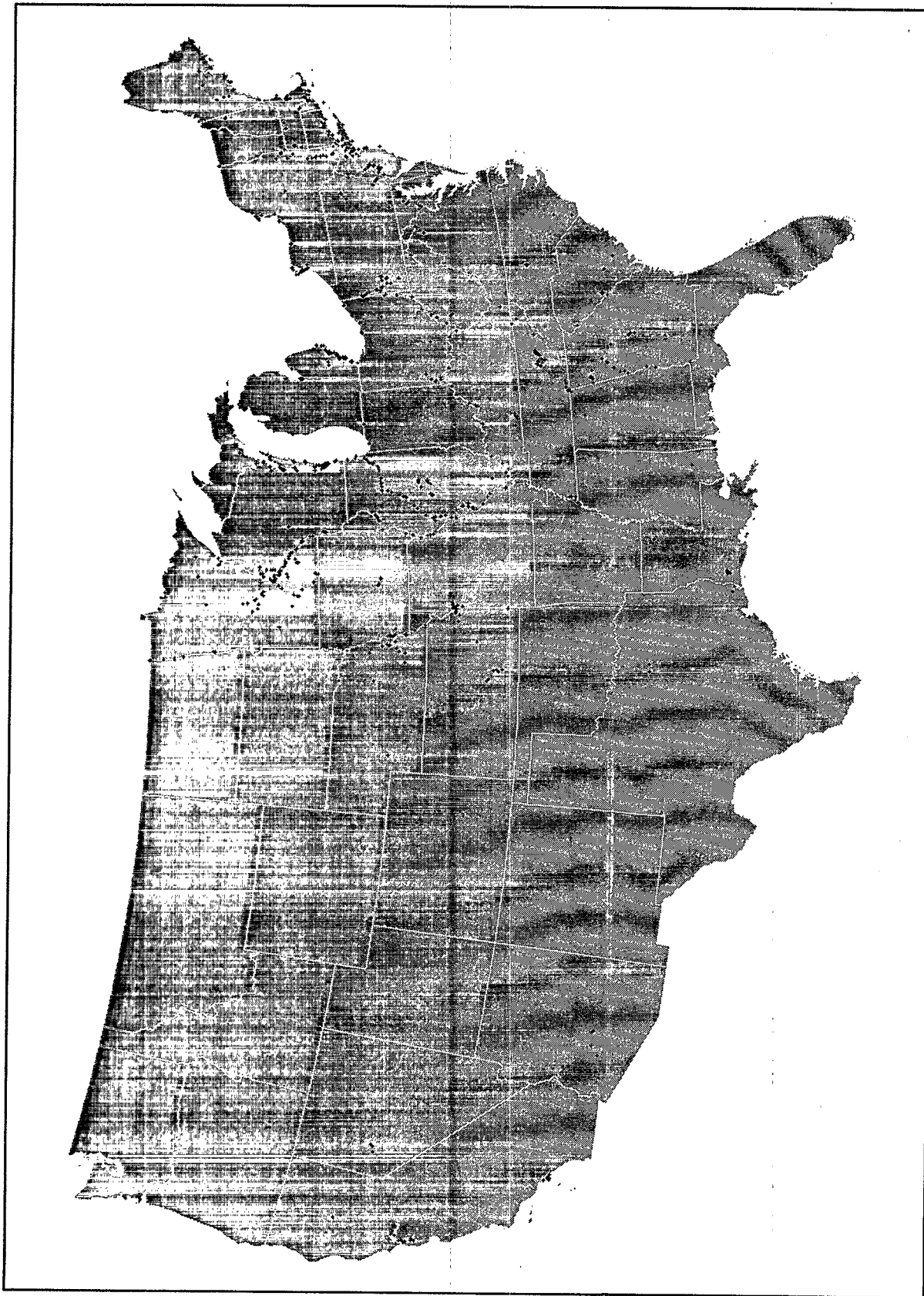

Figure 5-1. Tier 1 and Tier 2 Sampling Stations for Potential Risk to Human Health Located Within Water Bodies with Fish Consumption Advisories in Place for the Same Chemical Responsible for the Tier 1 or Tier 2 Classification.

Unfortunately, the bioaccumulation potential of mercury based on concentrations in sediment cannot be assessed because the biota sediment accumulation factors (BSAFs) used for this study apply only to nonionic organic compounds. In addition, available fish tissue data for mercury did not place a large number of sampling stations in Tier 2 for potential human health effects, compared to the number of fish consumption advisories issued.

There are three possible explanations for the relatively small number of sampling stations categorized as Tier 2 for mercury in comparison to the number of fish consumption advisories in place for mercury. The first explanation is that the NSI evaluation was limited to data from resident demersal species, whereas data used in support of issuing state fish advisories probably included pelagic and migratory species. The second possible explanation is that the evaluation parameters used in the analysis were not as stringent as the ones used to support fish consumption advisory issuance. The third explanation is that the NSI does not include all of the data used by the states to issue fish advisories.

To examine these possible explanations, EPA performed additional analyses of mercury fish tissue data included in the NSI. The current evaluation, using a fish tissue screening value of 1 part per million (ppm), yields 103 Tier 2 sampling stations (4 percent of all stations with detectable levels). If data from all edible pelagic and migratory species are included in the analysis, there are 374 Tier 2 sampling stations (9 percent of all stations with detectable levels). A fish tissue threshold of 0.6 ppm, derived using the more stringent reference dose (0.00006 mg/kg-day) recommended to states for issuing fishing advisories to protect against developmental effects among infants (USEPA, 1994f), yields 821 Tier 2 sampling stations (20 percent of all stations with detectable levels) when applied to all edible species using the consumption rate for an average consumer of 6.5 grams per day. However, fish consumption advisories are often issued for more highly exposed populations, such as recreational or subsistence fishers. The 0.2 ppm Canadian guideline limit for mercury in fish that are part of a subsistence diet yields 2,308 Tier 2 sampling stations (56 percent of all stations with detectable levels) when applied to all edible species in the NSI database. Further details of the additional mercury analyses are provided in Appendix H.

The conclusion resulting from these additional analyses is that all three explanations for the discrepancy in numbers of fish advisories and Tier 1 and Tier 2 sampling stations for mercury probably have an effect. Most fish consumption advisories are issued to protect infants from developmental effects for populations where exposure is

greater than 6.5 grams of fish per day. It is also likely that many of the data used to develop state fish consumption advisories are not included in the NSI, or are not evaluated for sediment contamination because they are measurements in pelagic or migratory fish.

Sensitivity of Selected PCB Evaluation Parameters

Because PCBs and dioxin are extremely hydrophobic chemicals commonly associated with sediment, and because of their toxicity to humans, EPA believes that elevated levels of PCBs and dioxins in fish tissue of resident, demersal species are sufficient evidence to indicate a higher probability of adverse human health effects and to place a sampling station in Tier 1. Based on the NSI data evaluation, PCBs were responsible for the Tier 1 classification of more sampling stations than any other chemical. Therefore, EPA conducted a sensitivity analysis of some PCB evaluation parameters to determine the effect on the number of sampling stations classified as Tier 1 or Tier 2.

In the NSI evaluation, EPA selected a precautionary approach for the analysis of PCBs. The approach is precautionary because it does not require matching sediment chemistry and tissue residue data for PCB, and it is based on the risk of cancer for all PCBs congeners or total PCB measurements. However, some PCB congeners are considered a greater threat for noncancer effects than for cancer. The evaluation currently places 2,256 tissue sampling stations in Tier 1 based on human health cancer risk. Only 542 of these sampling stations included matching sediment and tissue data for PCBs. Therefore, the number of sampling stations classified as Tier 1 would have decreased significantly if this match had been required.

EPA performed additional evaluations to determine the number of sampling stations that exceed other screening values which are less precautionary than those selected for the PCB evaluation in this study. The complete results are presented in Appendix H, which includes a comparison of the number of sediment and fish tissue sampling stations with detectable levels of PCBs that exceed various evaluation parameters for both aquatic life and human health.

Sampling station evaluation based on PCB contamination is quite sensitive to the selection of evaluation parameters. For protection of fish consumers, there are essentially three distinct levels of protection. Using an EPA cancer risk of 10^{-5} (i.e., a 1 in 100,000 extra chance of cancer over a lifetime of 70 years) or greater, 85 percent or

more of the sampling stations with detectable PCB levels are classified as Tier 1. About one-half to two-thirds of the sampling stations are classified as Tier 1 for exceedances of PCB levels protective of noncancer health effects, cancer risk at a 10^{-4} risk level, or levels exceeding the wildlife criterion. Less than one-third of the stations are classified as Tier 1 using the FDA level of protection. As documented in Appendix H, these percentages vary depending on use of a BSAF safety factor, and whether one is examining the set of fish tissue data or sediment chemistry data. These three levels of protection vary within two orders of magnitude, a range that covers most of the distribution of PCB measurements.

Although sampling station classification for PCB contamination is quite sensitive to selection of evaluation parameters, overall station classification using the complete NSI evaluation for all chemicals is more robust. Using the selected PCB evaluation parameters, there are 15,922 total Tier 1 and Tier 2 sampling stations. If PCBs are dropped from the analysis entirely, the total number of Tier 1 and Tier 2 sampling stations remains about the same (less than a 5 percent decrease), but the number of Tier 1 sampling stations decreases by approximately 40 percent. If PCBs are evaluated using a noncancer human health threshold, the total number of Tier 1 and Tier 2 sampling stations decreases by less than 2 percent and the number of Tier 1 sampling stations decreases by approximately 12 percent. Figure 5-2 shows the location of Tier 1 and Tier 2 sampling stations that exhibit potential human health risks for all chemicals other than PCBs for comparison to Figure 3-6 in the results section. Approximately 78 percent (6,670 of 8,523) of the total number of Tier 1 and Tier 2 sampling stations indicating human health risk remain after excluding PCBs from the evaluation.

Strengths of the NSI Data Evaluation

For this report to Congress, EPA has compiled the most extensive data base of sediment quality information currently available in electronic format. To evaluate these data, EPA has applied sediment assessment techniques in a weight-of-evidence approach recommended by national experts. The process to produce this report to Congress has engaged a broad array of government, industry, academic, and professional experts and stakeholders in development and review stages. The evaluation approach utilizes sediment chemistry, tissue residue, and toxicity test results. The assessment tools employed in this analysis have been applied in North America with results published in peer reviewed literature. Toxicity test data were generated using established standard

methods employed by multiple Federal agencies. The evaluation approach addresses potential impacts to both aquatic life and human health.

Because of the complex nature of the reactions among different chemicals in different sediment types, in water, and in tissues, no single sediment assessment technique can be used to adequately evaluate potential adverse effects from exposure to all contaminants. Uncertainties and limitations are associated with all sediment quality evaluation techniques. To compensate for those limitations, EPA has used multiple assessment techniques, alone and in combination, to evaluate the NSI data. For example, EPA developed draft SQCs based on the best scientific data available and extensive peer review. Therefore, EPA believes that the draft SQCs are reliable benchmarks for protecting sediment quality, and with measured TOC can indicate a higher probability for adverse effects to aquatic life. In addition, EPA believes that other sediment chemistry screening values (ERMs/ERLs, PELs/TELs, AETs, and SQALs) are also useful indicators of probability for aquatic life impacts. The Agency applied a weight-of-evidence approach for evaluating contaminant levels using these screening values, requiring the exceedance of multiple upper sediment chemistry screening values (i.e., ERM, PEL, AET-high, or SQAL) for classification of Tier 1 sampling stations.

The screening values used to evaluate the NSI data include both theoretical and correlative approaches. The theoretical approaches (e.g., draft SQCs, SQALs, and TBPs) are based on the best information available concerning how chemicals react in sediments and organisms and how organisms react to those chemicals. The correlative approaches (i.e., ERM/ERLs, PELs/TELs, and AETs) are based on matched sediment and biological data gathered in the field and in the laboratory, and they provide substantial evidence of actual biological effects from sediments contaminated with specific concentrations of the chemicals.

The NSI evaluation approach includes assessments of potential impacts to both human health and aquatic life. Some chemicals pose a greater risk to human health than to aquatic life; for others, the reverse is true. By evaluating both potential human health and aquatic life impacts, EPA has ensured that the most sensitive endpoint is used to assess environmental impacts.

Because sediment chemistry data are not the only indicators of potential environmental degradation due to sediment contamination, the NSI data evaluation approach also includes evaluations of fish tissue residue and toxicity data. If high levels of PCBs or dioxins (which are highly

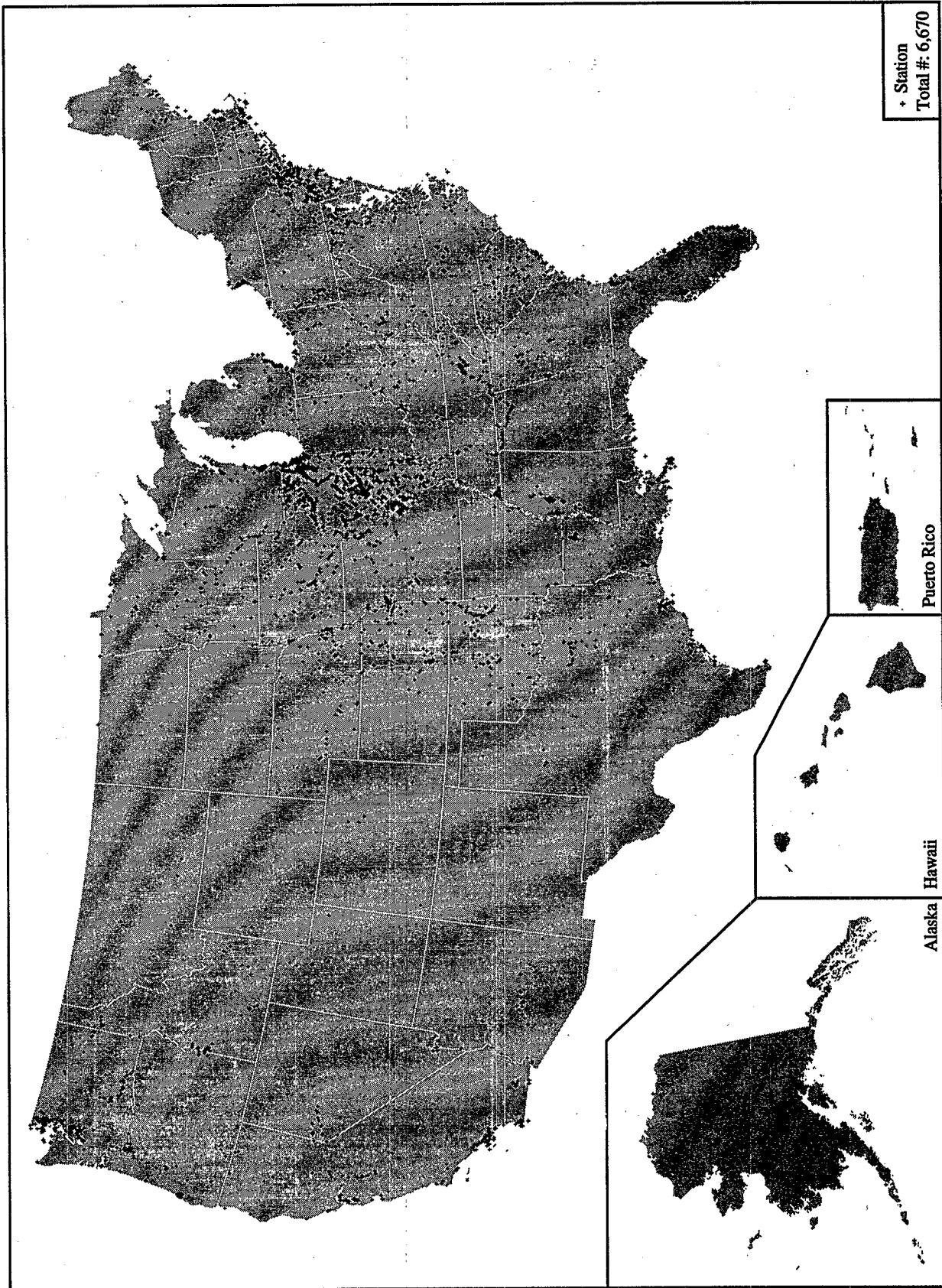

Figure 5-2. Sampling Stations Classified as Tier 1 or Tier 2 for Potential Risk to Human Health Excluding PCBs.

hydrophobic organic chemicals commonly found associated with sediments) were measured in fish tissue at a given sampling station, the station could be categorized as Tier 1 with no corroborating sediment chemistry data. For other chemicals, high concentrations in tissues alone were not sufficient to categorize a sampling station as Tier 1; corroborating sediment chemistry data were also required. For a sampling stations to be categorized as Tier 1 based on toxicity data alone, multiple toxicity tests with positive results using two different test species were required. One of the tests had to be a solid-phase test.

Although EPA has developed draft SQCs for only five nonionic organic chemicals, the Agency has developed similar values, the SQALs, for an additional 35 chemicals as part of the NSI data evaluation. The SQALs have allowed EPA to evaluate more chemicals using multiple assessment techniques, thereby adding more weight of evidence to the results of this evaluation.

Limitations of the NSI Data Evaluation

This methodology was designed for the purpose of a screening-level assessment of sediment quality. A considerable amount of uncertainty is associated with the site-specific measures, assessment techniques, exposure scenarios, and default parameter selections. Therefore, the results of evaluating particular sampling stations based on this methodology should be followed up with more intensive assessment efforts, when appropriate (e.g., for water bodies with multiple Tier 1 sampling stations located in APCs). Two types of limitations are associated with the evaluation of the NSI data: limitations associated with the data themselves and limitations associated with the evaluation of the data.

Limitations of Data

The NSI is a multimedia compilation of environmental monitoring data obtained from a variety of sources, including state and federal government offices. Inherent in the diversity of data sources are contrasting monitoring objectives and scopes, which make comparison of data from different data sets difficult. For example, several of the databases contain only information from marine environments or other geographically focused areas. The potential for inconsistencies in measured concentrations of contaminants at different stations exists for samples taken from different monitoring programs. For example, sampling different age profiles in sediments, applying different sampling and analysis methods, and sampling for different objectives can affect the results of

the NSI evaluation. Although numerous data sets identified sampling and laboratory methods, most data did not have this information. In addition, some data sets included in the NSI were not peer-reviewed (i.e., Region 4's Sediment Quality Inventory, the Gulf of Mexico Program's Contaminated Sediment Inventory, and some data sets from EPA's STORET). Furthermore, each monitoring program used unique sampling and analysis protocols. For example, PCBs, the chemical group most often responsible for placing sites in Tier 1, were measured by nearly all of the programs but were analyzed and reported as aroclor-specific data, congener-specific data, total PCBs, or a combination of these.

The only quality assurance/quality control (QA/QC) information required for data to be included in the NSI was information on the source of the data and the location of the sampling station. Available information on several types of QA/QC procedures that can influence the quality of the data and can be used to check the quality of data was included in the NSI. None of this information, however, was required before a data set could be included in the NSI. Evaluation of such information can provide an indication of the quality of the data used to target a specific site. Table 5-2 presents a summary of the known QA/QC information associated with each of the data sets included in the NSI.

Data reporting was also inconsistent among the different data sources. Inconsistencies that required resolution included the lack or inconsistent use of Chemical Abstract Service (CAS) numbers, analyte names, species names, and other coding conventions, as well as the lack of detection limits and associated data qualifiers (remark codes). The evaluation of toxicity data required the presence of control data. Control data were not often initially reported with the data, and significant follow-up work was required to acquire such data. In addition, 4 of the 11 sources of toxicity test data used in the NSI evaluation did not report the use of laboratory replicates.

Some of the data included in the NSI were compiled as early as 1980 (the data cover the period of 1980-93) and might not reflect current conditions. The analysis did not include a temporal assessment of trends in sediment contaminant levels. Emissions of many prominent contaminants declined during the 1980s, and significant remediation efforts have taken place at many locations since that time. In addition, dredging, burial, and scouring might have removed contaminants from some sampling stations. The lack of a trend analysis in sediment contamination over time is an important limitation of this study and will be investigated in future NSI evaluations.

Table 5-2. National Sediment Inventory Database: Summary of QA/QC Information

Database	Are There QA/QC Reports to Accompany the Data?	Were the Data Peer-Reviewed?	Are the Sampling and Analytical Methods Identified in the Database?	Are the Detection Limits for the Analytes Included in the Database?	Comments
ODES	Yes	Yes, 301(h) data	Yes	Yes	Data Qualifiers
EMAP (VA and LA Provinces)	Yes	Yes	Yes	Yes	Data Qualifiers
Seattle; U.S. Army Corps of Engineers	Yes	Yes	Yes	Yes	Data Qualifiers
Region 4	Some	No	Some	Yes	Data Qualifiers
Gulf of Mexico	Some	No	Some	Yes	Data Qualifiers
COSED	Yes	Yes	Yes	Some	
Great Lakes	Yes	Yes	Yes	Yes	
DMATS	Some	Yes	Yes	Yes	Data Qualifiers
STORET	Unknown	Unknown	No	Yes	Data Qualifiers
Massachusetts Bay (USGS)	Some	Yes	Yes	Yes	

Some data parameters are consistently absent throughout the NSI database. (Refer to Appendix A, Tables A-1 and A-2, for information on the number of NSI stations at which the various types of data were collected.) For example, very few site-specific TOC or AVS data are available, and toxicity data or matched sediment chemistry and biological data were available at relatively few sampling stations. For many of the fish tissue data included in the NSI, the species was not identified.

The lack of AVS data in the NSI was a significant limitation for the evaluation of metals data. The NSI includes a relatively large amount of metals data, and the data indicate that metals concentrations in sediment are elevated in many areas. At some stations the elevated metals concentrations might indicate a potential problem; however, no sampling stations in the NSI could be placed in Tier 1 solely from measured concentrations of cadmium, copper, nickel, lead, or zinc. This reflects in large part the absence of AVS data, which are required to place sampling stations contaminated with those metals in Tier 1.

The unavailability of matching sediment chemistry and tissue residue data also limited the NSI data evaluation. In several instances, fish tissue was not analyzed for the same suite of chemicals for which sediment was analyzed. Spatial and temporal limitations of the data might have directly affected the analysis. Although some sediment chemistry and tissue residue data might have been

collected in the same or very similar sampling stations, if the station names were not identical, the data could not be treated as if they were collected from the same location. This very likely resulted in an underestimate of the number of Tier 1 stations identified based on potential human health effects. The underestimate occurred because exceedances of sediment TBP and tissue levels (EPA risk levels and FDA levels) at the same sampling station were required to categorize stations as Tier 1.

The lack of consistency among the different monitoring programs in the suite of chemicals analyzed also represents an area of uncertainty in the NSI data evaluation. Certain databases contain primarily information describing concentrations of metals or pesticides, whereas others (e.g., STORET and ODES) contain data describing concentrations of nearly every chemical monitored in all of the NSI data. Many monitoring programs use a screening list of chemicals that are indicator pollutants for contaminated sediments. Thus, many of the specific chemicals assessed in the NSI data evaluation are not always measured in samples. In addition, certain classes of in-place sediment contaminants might not be recognized as causing significant impacts and thus are not routinely measured.

Information describing local background levels of sediment contaminants was usually not presented with the data included in the NSI and thus was not considered when the significance of elevated contaminant concen-

trations in sediment was evaluated. Background conditions can be important in an evaluation of potential adverse effects on aquatic life because ecosystems can adapt to their ambient environmental conditions. For example, high metals concentrations in samples collected from a particular station might occur from natural geological conditions at that location, as opposed to the effects of human activities.

Most data are associated with a specific location. As a result, establishing the extent of contaminated sediment within a water body is not possible because it is difficult to assess the extent to which a monitoring station represents a larger segment of a water body. Furthermore, the NSI data are geographically biased. More than 50 percent of all sampling stations evaluated in the NSI are located in 8 states (Washington, Florida, Illinois, California, Virginia, Ohio, Massachusetts, and Wisconsin), which have more than 700 monitoring stations each. Finally, EPA did not verify reported latitude and longitude coordinates for each sampling station.

Limitations of Approach

Sediment Chemistry Screening Values

There are significant gaps in our knowledge concerning sediment-pollutant chemistry (especially bioavailability) and direct and indirect effects on aquatic biota. The certainty with which sediment toxicity can be predicted for each chemical using the various screening values included in the NSI evaluation can vary significantly based on the quality of the available data and the appropriateness of exposure assumptions. For example, draft SQCs and SQALs are not equivalent, even though they were developed using the same methodology. EPA has proposed SQCs for five chemicals based on the highest quality toxicity and octanol/water partitioning data, which have been reviewed extensively. The draft SQCs have also undergone extensive field validation experiments. However, SQALs for additional chemicals are in many cases based on a less extensive toxicity data set and have not been field validated. The AET values used in this evaluation were based on empirical data from Puget Sound. Direct application of values from Puget Sound to a specific location or region in another part of the country might be overprotective or underprotective of the resources in that area. Extensive collection of data and additional analyses would be required to develop AETs for other locations.

The bioavailability of metals in sediment is addressed by the comparison of the molar concentration of sulfide anions (i.e., acid-volatile sulfide [AVS]) to the molar con-

centration of metals (i.e., simultaneously extracted metals [SEM]). The [SEM]-[AVS] difference is most applicable as an indicator of when metals are not bioavailable. If [AVS] exceeds [SEM], there is sufficient binding capacity in the sediment to preclude metal bioavailability. However, if [SEM] exceeds [AVS], metals might be bioavailable or other nonmeasured phases might bind up the excess metals. To apply the [SEM]-[AVS] difference to indicate positive bioavailability and toxicity for this evaluation, EPA used laboratory data that indicated the probability of observed toxic effects at various [SEM]-[AVS] levels. Based on these data, EPA defined the Tier 1 level as [SEM]-[AVS]>5. Thus, this use of [SEM]-[AVS] represents a hybrid of a theoretical approach and a correlative approach.

Only those chemicals for which sediment chemistry screening values (i.e., draft SQCs, SQALs, ERLs/ERMs, PELs/TELS, and AETs) are available were evaluated in the analysis of NSI data. Therefore, the methodology could not identify contamination associated with chemical classes such as ionic organic compounds (e.g., alkyl phenols) and organometallic complexes (e.g., tributyl tin).

Biological effects correlation approaches such as ERM or PELs are based on the evaluation of paired field and laboratory data to relate incidence of adverse biological effects to the dry-weight sediment concentration of a specific chemical at a particular sampling station. Researchers use these data sets to identify level-of-concern chemical concentrations based on the probability of observing adverse effects. Exceedance of the identified level-of-concern concentration is associated with a likelihood of adverse organism response, but it does not demonstrate that a particular chemical is solely responsible. In fact, a given sample typically contains a mixture of chemicals that contribute to observed adverse effects to some degree. Therefore, these correlative approaches tend to result in screening values that are lower than the theoretical draft SQCs and SQALs, which address the effects of a single contaminant. However, these correlative approaches are better at predicting toxicity in complex mixtures of contaminants in sediment. The effects range approaches to assessing sediment quality also do not account for such factors as organic matter content and AVS, which can mitigate the bioavailability and, therefore, the toxicity of contaminants in sediment.

Another concern is the application of screening values based on freshwater data (draft SQCs and SQALs) and those based on saltwater data alone (ERLs/ERMs, PELs/TELS, and AETs) to evaluate sediment contaminant concentrations in the NSI from both freshwater and saltwater habitats. Freshwater organisms exhibit tolerance to

toxic chemicals similar to that of saltwater species when tested in their respective water; however, estuarine organisms might be less tolerant if osmotically stressed (Rand and Petrocelli, 1985). Thus, the relative toxicity of a chemical in water (i.e., its chronic threshold water concentration) is usually within an order of magnitude for saltwater and freshwater species, although final chronic values and proposed sediment quality criteria values are usually slightly higher for saltwater species. Ingersoll et al., (1996) reported similar reliability and predictive ability between marine and freshwater guidelines. In addition Long et al., (1995) compared the ERLs and ERMs with comparable values derived for freshwater by the Ontario Ministry of the Environment and the agreement was extremely good. Because of limitations of time and resources, sampling stations in the NSI were not classified by salinity regime, and further site-specific evaluations are required to more definitively assess the toxicity at the stations. However, the application of several different screening values should provide a reasonable estimate of probability of risk to aquatic life in freshwater, estuarine, and marine habitats.

Additional false positive and false negative classifications of risk to aquatic life from sediment contaminant concentrations could occur when a default value for organic carbon content is applied. Draft SQCs and SQALs are based on the partitioning of a chemical between organic carbon in the sediment and pore water at equilibrium. Because the organic carbon content of most sediment samples in the NSI is unknown, these sediment samples were assumed to contain 1 percent organic carbon. Total organic carbon (TOC) can range from 0.1 percent in sandy sediments to 1 to 4 percent in silty harbor sediments and 10 to 20 percent in navigation channel sediments (Clarke and McFarland, 1991). Long et al. (1995) reported an overall mean TOC concentration of 1.2 percent from data compiled from 350 publications for their biological effects database for sediments. Ingersoll et al. (1996) reported a mean TOC concentration of 2.7 percent with a 95 percent confidence interval of only 0.65 percent. In contrast, the concentration ranges of contaminants normalized to dry weight typically varied by several orders of magnitude. Therefore, normalizing dry-weight concentrations to a relatively narrow range of TOC concentrations had little influence on relative concentrations of contaminants among samples. Similar findings were reported by Barrick et al., (1988) for AETs and Long et al. (1995) for ERMs calculated using sediment concentrations normalized to TOC concentrations.

Uncertainty associated with the equilibrium partitioning theory for developing draft SQCs and SQALs includes the degree to which the equilibrium partitioning model

explains the available sediment toxicity data (USEPA, 1993d). An analysis of variance using freshwater and saltwater organisms in water-only and sediment toxicity tests (using different sediments) was conducted to support development of the proposed sediment criteria. This analysis indicated that varying the exposure medium (i.e., water or sediment) resulted in an estimate of variability that should be used for computing confidence limits for the draft SQCs. The methodology used to derive the octanol/water partitioning coefficient and the final chronic value can also influence the degree of uncertainty associated with the draft SQCs. Differences in the response of water column and benthic organisms, and limitations in understanding the relationship of individual and population effects to community-level effects, have also been noted (Mancini and Plummer, 1994). Site-specific modifications to screening values derived using the equilibrium partitioning model have been recommended to better address chemical bioavailability and species sensitivities (USEPA, 1993b). Sediment chemistry screening values developed using the equilibrium partitioning approach also do not address possible synergistic, antagonistic, or additive effects of contaminants.

Based on the theoretical calculations used to compute SQAL values, it is possible that SQALs might be orders of magnitude larger or smaller than other screening values used for the analysis (ERLs/ERMs, PELs/TELS, and AETs). This might be a result of the limited aquatic toxicity data used to develop SQAL values for some of the contaminants for which water quality criteria are unavailable. EPA did not develop SQALs for this analysis in those cases where toxicity data were considered inadequate. The approach used to develop SQALs, and to choose chemicals for which SQALs could not be developed, is presented in Appendix B.

Fish Tissue Screening Values

The approach used to assess sediment chemistry data for the potential to accumulate in fish tissue also represents a theoretical approach with field-measured components. In addition to applying a site-specific or default organic carbon content, the TBP calculation includes a field-measured biota sediment accumulation factor (BSAF) to account for the relative affinity of a chemical for fish tissue lipids or sediment organic carbon. The BSAF will account for the effects of metabolism and biomagnification in the organism in which it is measured. The primary limitation of this approach is the applicability of a field-measured BSAF, or a percentile from a distribution of values, at a variety of sites where the conditions may vary.

TBPs were assumed to be equivalent to levels detectable in fish tissue. However, this approach might not completely account for biomagnification in the food chain, especially when using a BSAF derived from a benthic organism. In addition, it is assumed that sediment does not move, that contaminant sources other than sediment are negligible, that fish migration does not occur, and that exposure is consistent. The TBP calculation assumes that various lipids in different organisms and organic carbon in different sediments are similar and have distributional properties similar to the field-measured values used to derive BSAFs. Other simplifying assumptions are that chemicals are similarly exchanged between the sediments and tissues and that compounds behave alike, independent of site conditions other than organic carbon content. In reality, physical-chemical processes (e.g., diffusion through porous media and sediment mixing) can vary and limit the rate at which chemicals can exchange with bottom sediments. Uptake of contaminants by aquatic organisms is also a kinetic (rate-controlled) process that can vary and be slowed, for example, by awkward passage of a bulky molecule across biological membranes. Also, a BSAF of 1 (thermodynamic equilibrium) was used to estimate TBPs for many nonpolar organics. This BSAF might overestimate or underestimate the bioaccumulative potential for certain nonpolar organic chemicals because it is assumed that there is no metabolic degradation or biotransformation of such chemicals. Site-specific organic carbon content was often not available, which leads to additional uncertainty concerning the comparability of BSAFs among different locations. In addition, development of the BSAFs used in the TBP evaluation relied on a large amount of data that have not been published or peer-reviewed. Because of these factors, actual residue levels in fish resulting from direct and/or indirect exposure to contaminated sediment might be higher or lower. There is therefore uncertainty regarding sampling stations classifications based on compar-

son of estimated TBPs with FDA tolerance/action and guideline levels and EPA risk levels.

TBPs could not be calculated for polar organic compounds or heavy metals. Therefore, sampling stations could not be classified using FDA levels or EPA risk levels for those chemicals using a TBP approach (although fish tissue monitoring data are often available for many stations).

Uncertainties and numerous assumptions are associated with exposure parameters and toxicity data used to derive EPA risk levels and FDA tolerance/action and guideline levels. For example, the derivation of EPA risk levels is based on the assumption that an individual consumes on average 6.5 g/day of fish caught from the same site over a 70-year period. Also, the TBP calculation for human health assessments assumes fish tissue contains 3 percent lipid. This value is intended to be indicative of the fillet rather than the whole body. Generally, the exposure assumptions and safety factors incorporated into toxicity assessments might overestimate risks to the general population associated with sediment contamination, but might underestimate risks to populations of subsistence or recreational fishers.

Other Limitations

Because a numerical score was not assigned to each sampling station to indicate the level of contamination associated with that station, it is not possible to determine which of the stations in Tier 1 should be considered the "most" contaminated. Such a numerical ranking system was intentionally not used for the NSI data evaluation because EPA does not believe that such ranking is appropriate for a screening-level analysis such as this, given the level of uncertainty.

Chapter 6

Recommendations

The following discussion presents EPA's recommendations for addressing sediment contamination throughout the country and for improving the ability to conduct sediment quality assessments. These recommendations relate to five activities or information needs:

1. Further investigate conditions in the 96 targeted watersheds.
2. Coordinate efforts to address sediment quality through watershed management programs.
3. Incorporate a weight-of-evidence approach and measures of chemical bioavailability into sediment monitoring programs.
4. Evaluate the National Sediment Inventory's (NSI's) coverage and capabilities and provide better access to information in the NSI.
5. Develop better monitoring and assessment tools.

Recommendation 1: Further Investigate Conditions in the 96 Targeted Watersheds

To characterize the incidence and severity of sediment contamination in the United States, EPA has performed a screening-level analysis of the information in the NSI, the results of which are presented in Chapter 3. As mentioned previously, the results of the NSI data evaluation alone should not be used as justification for taking corrective actions at potentially contaminated sites. The initial evaluation of NSI data was performed as a means of screening and targeting. Additional, site-specific data and information should be gathered to verify the NSI evaluation results and to support a comprehensive assessment of the incidence and severity of sediment contamination problems.

The primary recommendation resulting from the NSI data analysis is to encourage further investigation and

assessment of contaminated sediment. States, in cooperation with EPA and other federal agencies, should proceed with further evaluations of the 96 watersheds containing areas of probable concern for sediment contamination (APCs). In many cases, it is likely that much additional investigation and assessment has already occurred, especially in well known areas at risk for contamination, and some areas have been remediated. If active watershed management programs are in place, these evaluations should be coordinated within the context of current or planned actions. Future monitoring and assessment efforts should focus on areas such as the 57 water body segments (or river reaches) located within the 96 watersheds containing APCs that had 10 or more stations categorized as Tier 1. The purpose of these efforts should be, as appropriate, to gather additional sediment chemistry data and related biological data and conduct further assessments of the data to determine human health and ecological risk, determine temporal and spatial trends, identify potential sources of sediment contamination and determine whether potential sources are adequately controlled, and determine whether natural recovery is a feasible option for risk reduction. Additional monitoring and analysis of data from the 96 watersheds containing APCs will also be used to track and document the effectiveness of management actions taken to address sediment contamination problems over time. Trends in sediment contamination in the 96 APCs over time will be reported in future reports to Congress.

Available options for reducing health and environmental risks from contaminated sediment include physical removal and land disposal; subaqueous capping; *in situ* or *ex situ* biological, physical/chemical, or thermal treatment to destroy or remove contaminants; and natural recovery through continuing deposition of clean sediment. Assuming further investigation reveals the need for management attention to reduce risks, the preferred means depends on factors such as the degree and extent of contamination, the value of the resource, the cost of available options, likely human and ecological exposure, and the acceptable time period for recovery. If risk managers anticipate a lengthy period of time prior to recovery of the system, state and local authorities can consider

Although some historical trend information is available, a comprehensive assessment of temporal trends is not presented in the current report to Congress. EPA should consider whether to design future evaluations of the NSI data to determine where and why sediment quality conditions are improving or worsening. EPA plans to develop an approach for assessing temporal trends that might include, for example, a statistical analysis of recent and older data from national databases that are updated on a regular basis, such as STORET, ODES, and the National Oceanic and Atmospheric Administration's NS&T database. In addition, in the search for additional databases for use in future NSI data evaluations, EPA should focus on obtaining sediment core data, which can provide valuable information concerning historical trends in sediment contamination. An assessment of temporal trends in sediment contamination will provide valuable information concerning the effectiveness of measures taken to control the release of sediment contaminants.

The NSI can be a powerful tool for water resource managers at the national, regional, state, watershed, and water body levels. It provides in a single place a wealth of information that could be very useful, especially with improved access and availability. Multiple agencies should have access to the same data for decision makers in regional management, state-level management, and watershed-level management.

Plans are under development to make this happen. By the summer of 1997 the NSI data, organized by watershed and including maps and summary tables, should be available on EPA's mainframe computer for on-screen viewing and download. In addition, near future plans are to make this information available on EPA's World Wide Web site. EPA has also included the NSI data in its comprehensive GIS/modeling system, BASINS (Better Assessment Science Integrating Point and Nonpoint Sources). Future activities should include the addition of the NSI evaluation tools to BASINS to allow users to query the NSI evaluation results. For managers, this could be useful for identifying watersheds, water bodies, or sampling stations where various sediment chemistry and/or biological screening values have been exceeded. Identifying potential point and nonpoint sources of sediment contaminants is also critical.

Increased access to data and information in the NSI has many implications. At the national level, the data and information can:

- Demonstrate the need and provide impetus for increased pollution prevention efforts.

- Demonstrate the need for safer or biodegradable chemicals.
- Determine relative risk compared to other problems.

At the state and watershed level, better access to NSI information can help in:

- Educating and involving the public.
- Setting goals and prioritizing activities and expenditures.
- Evaluating the adequacy and effectiveness of control actions, clean-up activities, and other management actions.

Related to source identification are plans under way at the Agency for one-stop reporting of and access to integrated information about the environmental performance and emissions of major industrial facilities and other pollution sources. States and EPA will give every major industrial facility and other type of facility generating, storing, and disposing of hazardous and toxic wastes a unique identifying number. This number will be used by states and EPA to link all environmental information related to the facility. NSI development will be linked to these Agency-level efforts.

Interagency and intergovernmental cooperation is essential for enhancing NSI information, coverage, and comprehensiveness. Reporting of water quality information and environmental indicator development at the Office of Water are important ongoing efforts related to the collection of information from state agencies (through 305(b) reporting), other federal agencies, and the private sector. Efforts for future data collection for the NSI should be integrated into these related initiatives.

Recommendation 5: Develop Better Monitoring and Assessment Tools

The National Sediment Quality Survey is the first attempt to analyze sediment chemistry and biological data from numerous databases from across the country in an effort to identify the national incidence and severity of sediment contamination. Because the data were not generated by a single monitoring program designed at the outset to provide this national picture, numerous hurdles had to be overcome to analyze the data with as little bias and as much scientific validity as possible. This exercise itself provided an opportunity to assess the needs to develop better basic and applied science with respect to sediment chemistry data and related biological data.

To ensure effective quality control and quality assurance management, monitoring programs should adopt standard sample collection, storage, analyses, and documentation procedures. Lack of available quality control information and the recognized limitations of some past sampling and analyses methods necessarily restricts the interpretation of much of the historical data base. However, these limitations should be eliminated in the future through current practices such as "clean" laboratory techniques, lowered analytical detection limits, and better record keeping. Modernization of federal and other data repositories to accommodate the storage of much additional valuable and relevant information should help facilitate the process.

During the evaluation of information in the NSI, analysts continually came up against the limitations of available tools and techniques to assess the sediment contaminant information. Although screening values were adopted or developed for the NSI data evaluation wherever feasible, many data for some potentially harmful contaminants were not evaluated. For example, many contaminants included in the NSI, such as kepone and tributyl tin, could not be evaluated due to a lack of appropriate screening values for comparison with measured values.

The sediment quality evaluation tools used for the current NSI data evaluation should be used as the basis for further methods development. As sediment quality data become more available and the state of the science for sediment assessment evolves, assessment methods will also evolve. For example, new and better screening values and laboratory tests for biological effects will be developed. EPA should incorporate new sediment assessment techniques into future NSI data evaluations as they are developed, tested, and proven reliable. For ex-

ample, although biological community data were included in the NSI, the data were not evaluated for this report to Congress because there is little agreement among sediment assessment experts concerning biological community conditions that can be directly related to sediment quality problems. EPA should work to develop these and other sediment assessment tools for future assessments. EPA needs to evaluate the ecological relevance of the assessment tools used to evaluate contaminated sediment.

Other relevant issues and science needs that should be addressed to better characterize the sources, fate, and effects of sediment contaminants include:

- Methods to better predict the fate and transport of sediment contaminants.
- Methods to predict or track atmospheric sources and cross-media transfers of sediment contaminants such as mercury, pesticides, PCBs, and PAHs.
- Bioavailability of compounds other than non-ionic organics.
- Estimates of land use impacts on sediment conditions (predictive capabilities).
- Methods for fingerprinting chemicals for source identification.

In the context of the budget process, EPA and other federal agencies should evaluate whether to request funding to support the development of tools to better characterize the sources, fate, and effects of sediment contaminants.

Glossary

Acid-volatile sulfide (AVS): Reactive solid-phase sulfide fraction that can be extracted by cold hydrochloric acid. Appears to control the bioavailability of most divalent metal ions because of the sulfide ions' high affinity for divalent metals, resulting in the formation of insoluble metal sulfides in anaerobic (anoxic) sediments.

Acute toxicity: Immediate or short-term response of an organism to a chemical substance. Refers to generalized toxic response with lethality usually being the observed endpoint.

Apparent Effects Thresholds (AETs): Sediment chemistry screening values based on a biological effects correlation approach. The AET is the highest concentration at which statistically significant differences in observed adverse biological effects from reference conditions do not occur, provided that the concentration also is associated with observance of a statistically significant difference in adverse biological effects. Based on empirical data from Puget Sound. EPA defined the AET-low as the lowest AET among applicable biological indicators, and the AET-high as the highest AET among applicable biological indicators.

Benthic abundance: The quantity or relative degree of plentifulness of organisms living in or on the bottom of streams, rivers, or oceans.

Benthic organisms: Species living in or on the bottom of streams, rivers, or oceans.

Bioavailability: The fraction of chemical present that is available for uptake by aquatic organisms.

Biological community: An assemblage of organisms that are associated in a common environment and interact with each other in a self-sustaining and self-regulating relationship.

Biological effects correlation approach: A method for relating the incidence of adverse biological effects to the dry-weight sediment concentration of a specific chemical at a particular site based on the evaluation of paired field and laboratory data. Exceedance of the identified level of concern concentration is associated with a likeli-

hood of adverse organism response, but does not demonstrate that a particular chemical is solely responsible.

Cataloging unit: Sometimes referred to as a hydrologic unit, corresponds to a watershed that was delineated by the U.S. Geological Survey. A watershed is an area that drains ultimately to a particular watercourse of body of water. There are approximately 2,100 cataloging units in the contiguous United States, which are, on average, somewhat larger than counties. Each cataloging unit is uniquely identified with an 8-digit hydrologic unit code (HUC).

Chronic toxicity: Response of an organism to repeated, long-term exposure to a chemical substance. Typical observed endpoints include growth and reproduction.

Combined sewer overflow: A discharge of a mixture of storm water and untreated domestic wastewater that occurs when the flow capacity of a sewer system is exceeded during a rainstorm.

Contaminated sediment: Sediment that contains chemical substances at concentrations that pose a known or suspected threat to aquatic life, wildlife, or human health.

Demersal species: Swimming organisms that prefer to spend the majority of their time on or near the bottom of a water body.

Divalent metals: Metals that are available for reaction in a valence state of two (i.e., carrying a positive electric charge of two units).

Ecosystem: An ecological unit consisting of both the biotic communities and the nonliving (abiotic) environment, which interact to produce a system which can be defined by its functionality and structure.

Effects range-median (ERM) and effects range-low (ERL) values: Sediment chemistry screening values based on a biological effects correlation approach. Represent chemical concentration ranges that are rarely (i.e., below the ERL), sometimes (i.e., between ERL and ERM), and usually (i.e., above the ERM) associated with toxic-

ity for marine and estuarine sediments. Ranges are defined by the tenth percentile and fiftieth percentile of the distribution of contaminant concentrations associated with adverse biological effects.

Elutriate phase toxicity test: Toxicity test in which sediments are mixed with test water for a fixed period of time, the test water is then siphoned off, and test organisms are introduced to the test water (the elutriate) in the absence of sediments. Useful for representing the exposure to chemicals that can occur after sediments have been resuspended into the water column or after they have passed through the water column as part of dredged material disposal operations.

Equilibrium concentration: The concentration at which a system is in balance due to equal action by opposing forces within the system. When the partitioning of a nonionic organic chemical between organic carbon and pore water and partitioning of a divalent metal between solid and solution phases are assumed to be at equilibrium, an organism in the sediment is assumed to receive an equivalent exposure to the contaminant from water only or from any equilibrated phase. The pathway of exposure might include pore water (respiration), sediment carbon (ingestion), sediment organism (ingestion), or a combination of routes.

Equilibrium partitioning (EqP) approach: Approach used to relate the dry-weight sediment concentration of a particular chemical that causes an adverse biological effect to the equivalent free chemical concentration in pore water and to that concentration sorbed to sediment organic carbon or bound to sulfide. Based on the theory that the partitioning of a nonionic organic chemical between organic carbon and pore water and the partitioning of a divalent metal between the solid and solution phases are at equilibrium.

Histopathology: The study of diseases associated with tissue changes or effects.

Hydrology: A science dealing with the properties, distribution, and circulation of water on the surface of the land, in the soil, and in the atmosphere.

Interstitial water: Water in an opening or space, as between rock, soil, or sediment (i.e., pore water).

Microbial toxicity test: Type of toxicity test in which members of the microbial community (i.e., bacteria) are used as the test organism. Microbial responses in toxicity tests have been recommended as early warning indicators of ecosystem stress. However, questions have

been raised concerning the sensitivity of sediment microbial toxicity testing.

Molar concentration: The ratio of the number of moles (chemical unit referring to the amount of an element having a mass in grams numerically equal to its atomic weight) of solute (the substance being dissolved or that present in the smaller proportion) in a solution divided by the volume of the solution expressed in liters.

National Sediment Inventory (NSI): A national compilation of sediment quality data and related biological data. Results of the evaluation of data from the NSI serve as the basis for the report to Congress on the incidence and severity of sediment contamination across the country (i.e., the National Sediment Quality Survey). Eventually, all compiled NSI data will be incorporated into the new, modernized STORET, where they will be permanently stored.

Nonionic organic chemicals: Compounds that do not form ionic bonds (bonds in which the electrical charge between bonded atoms in the compound is unequally shared). Nonionic compounds do not break into ions when dissolved in water and therefore are more likely to remain in contact with and interact with sediment compounds or other compounds in water.

Nonpoint source pollution: Pollution from diffuse sources without a single point of origin or pollution not introduced into a receiving stream from a specific outlet. Such pollutants are generally carried off the land by storm water runoff. Sources of nonpoint source pollution include atmospheric deposition, agriculture, silviculture, urban runoff, mining, construction, dams and channels, inappropriate land disposal of waste, and saltwater intrusion.

Nonpolar organic chemicals: Compounds that do not exhibit a strong dipole moment (there is little difference between the electrostatic forces holding the chemical together). Nonpolar compounds tend to be less soluble in water. In aquatic systems, nonpolar chemicals are more likely to be associated with sediments or other nonpolar compounds than with the surrounding water.

Point source pollution: Pollution contributed by any discernible, confined, and discrete conveyance including, but not limited to, any pipe, ditch, channel, tunnel, conduit, well, discrete fissure, container, rolling stock, concentrated animal feeding operation, or vessel or other floating craft, from which pollutants are or may be discharged.

Pore water: See Interstitial water.

Probable effects levels (PELs) and threshold effects levels (TELs): Biological effects correlation-based sediment chemistry screening values similar to ERMs/ERLs. A generalized approach used to develop effects-based guidelines for the state of Florida and others. The lower of the two guidelines for each chemical (i.e., the TEL) is assumed to represent the concentration below which toxic effects rarely occur. In the range of concentrations between the two guidelines, effects occasionally occur. Toxic effects usually or frequently occur at concentrations above the upper guideline value (i.e., the PEL). Ranges are defined by specific percentiles of both the distribution of contaminant concentrations associated with adverse biological effects and the "no effects" distribution.

River Reach: A stream segment between the consecutive confluences of a stream. Most river reaches represent simple streams and rivers, while some river reaches represent the shoreline of wide rivers, lakes, and coastlines. EPA's River Reach File 1 (RF1) was completed for the contiguous United States in the mid-1980s and includes approximately 68,000 river reaches. The average length of a river reach is 10 miles. The more detailed version of the Reach File (RF3) was not used for the National Sediment Inventory.

Sampling Station: A specific location associated with latitude/longitude coordinates where data have been collected. Defined by the data source, sponsoring agency, and station identification code. Multiple sampling stations can have the same latitude/longitude coordinates if labeled with a different station identification code for sampling performed on different dates or by different sponsoring agencies.

Sediment quality advisory levels (SQALs): Equilibrium partitioning-based sediment chemistry screening values. Derived using the same approach used to develop sediment quality criteria; however, SQALs may be based on a limited set of aquatic toxicity data.

Sediment quality criteria (SQC)s: Published draft sediment quality criteria for the protection of aquatic life. Based on the equilibrium partitioning-based approach using the highest quality toxicity and octanol/water partitioning data, which have been reviewed extensively. Draft SQCs have been developed by EPA for five non-

ionic organic chemicals: acenaphthalene, dieldrin, endrin, fluoranthene, and phenanthrene.

Simultaneously extracted metals (SEM): Metal concentrations that are extracted during the same analysis in which the acid-volatile sulfide (AVS) content of the sediment is determined.

Solid-phase toxicity test: A toxicity test in which test organisms are exposed directly to sediments. Sediments are carefully placed in the exposure chamber and the chamber is then filled with clean water. Resuspended particles are allowed to settle before initiation of exposure. Solid-phase toxicity tests integrate multiple exposure routes, including chemical intake from dermal contact with sediment particles as well as ingestion of sediment particles, interstitial water, and food organisms.

Theoretical bioaccumulation potential (TBP): An estimate of the equilibrium concentration of a contaminant in tissues if the sediment in question were the only source of contamination to the organism. TBP is estimated from the organic carbon content of the sediment, the lipid content of the organism, and the relative affinities of the chemical for sediment organic carbon and animal lipid content.

Total organic carbon (TOC): A measure of the organic carbon content of sediment expressed as a percent. Used to normalize the dry-weight sediment concentration of a chemical to the organic carbon content of the sediment.

U.S. Environmental Protection Agency (EPA) risk levels: Levels of contaminant concentrations in an exposure medium that pose a potential carcinogenic risk (e.g., 10^{-5} , or a 1 in 100,000 extra chance of cancer over a lifetime) and/or noncancer hazard (i.e., exceeds a reference dose). Used in this document to estimate human health risk associated with the consumption of chemically contaminated fish tissue.

U.S. Food and Drug Administration (FDA) tolerance/action or guideline levels: FDA has prescribed levels of contaminants that will render a food "adulterated." The establishment of action levels (the level of a food contaminant to which consumers can be safely exposed) or tolerances (regulations having the force of law) is the regulatory procedure employed by FDA to control environmental contaminants in the commercial food supply.

Acronyms

AET:	apparent effects threshold	NSI:	National Sediment Inventory
APC:	area of probable concern for sediment contamination	NURP:	National Urban Runoff Program
AVS:	acid volatile sulfide	ODES:	Ocean Data Evaluation System
BASINS:	Better Assessment Science Integrating Point and Nonpoint Sources (EPA modeling tool)	OST:	Office of Science and Technology, U. S. Environmental Protection Agency
BSAF:	biota-sediment accumulation factor	PAH:	polynuclear aromatic hydrocarbon
CAA:	Clean Air Act	PCB:	polychlorinated biphenyls
CAS:	Chemical Abstract Service	PCS:	Permit Compliance System
COSED:	Coastal Sediment Inventory	PEL:	probable effects level
CWA:	Clean Water Act	QA/QC:	quality assurance/quality control
CZMA:	Coastal Zone Management Act	RCRA:	Resource Conservation and Recovery Act
DMATS:	Dredged Material Tracking System	RF1:	River Reach File 1
EMAP:	Environmental Monitoring and Assessment Program	SEM:	simultaneously extracted metals
EPA:	U. S. Environmental Protection Agency	SQAL:	sediment quality advisory level
ERL:	effects range-low value	SQC:	sediment quality criteria
ERM:	effects range-median value	STORET:	Storage and Retrieval System
FDA:	Food and Drug Administration	TBP:	theoretical bioaccumulation potential
FIFRA:	Federal Insecticide, Fungicide, and Rodenticide Act	TEL:	threshold effects level
MPRSA:	Marine Protection, Research, and Sanctuaries Act	TIE:	toxicity identification evaluation
NEPA:	National Environmental Policy Act	TMDL:	total maximum daily load
NOAA:	National Oceanic and Atmospheric Administration	TOC:	total organic carbon
NPDES:	National Pollutant Discharge Elimination System	TRI:	Toxic Release Inventory
		TSCA:	Toxic Substance Control Act
		USACE:	U. S. Army Corps of Engineers
		USGS:	U. S. Geological Survey
		WRDA:	Water Resources Development Act of 1992

References

- Adams, W.J., R.A. Kimerle, and R.G. Mosher. 1985. Aquatic safety assessment of chemicals sorbed to sediments. In *Aquatic Toxicology and Hazard Assessment: Seventh Annual Symposium, American Society for Testing and Materials, Philadelphia, PA*, ed. R.D. Cardwell, R. Purdy, and R.C. Bahner, pp. 429-453.
- Allen, H.E., G. Fu, and B. Deng. 1993. Analysis of acid-volatile sulfide (AVS) and simultaneously extracted metals (SEM) for the estimation of potential toxicity in aquatic sediments. *Environ. Toxicol. Chem.* 12:1441-1453.
- API. 1994. *User's guide and technical resource document: Evaluation of sediment toxicity tests for biomonitoring programs*. API pub. no. 4607. Prepared for American Petroleum Institute, Health and Environmental Sciences Department, Washington, DC, by PTI Environmental Services, Bellvue, WA.
- Auerlich, R.J., R.K. Ringer, and S. Iwamoto. 1973. Reproductive failure and mortality in mink fed on Great Lakes fish. *J. Reprod. Fertil. Suppl.* 19:365.
- Baker, J.E., T.M. Church, S.J. Eisenreich, W.F. Fitzgerald, and S.R. Scudlark. 1993. *Relative atmospheric loadings of toxic contaminants and nitrogen to the great waters*. Prepared for U.S. Environmental Protection Agency, Office of Air Quality Planning and Standards, Pollution Assessment Branch, Durham, NC. Cited in USEPA, 1994a.
- Barrick, R., S. Becker, L. Brown, H. Beller, and R. Pastorok. 1988. *Sediment quality values refinement: 1988 update and evaluation of Puget Sound AET*. Vol. 1. Prepared for the Puget Sound Estuary Program, Office of Puget Sound.
- Baudo, R., and H. Muntau. 1990. Lesser known in-place pollutants and diffuse source problems. Chap. 1 in *Sediments: Chemistry and toxicity of in-place pollutants*, ed. R. Baudo, J. Giesy and H. Muntau. Lewis Publishers, Chelsea, MI.
- Baumann, P.C., W.D. Smith, and W.K. Parland. 1987. Tumor frequencies and contaminant concentrations in brown bullheads from an industrialized river and a recreational lake. *Trans. Amer. Fish. Soc.* 116:79-80.
- Becker, D.S., T.C. Ginn, M.L. Landolt, and D.B. Powell. 1987. Hepatic lesions in English sole (*Parophrys vetulus*) from Commencement Bay, Washington (USA). *Mar. Environ. Res.* 23:153-173.
- Berry, W., M. Cantwell, P. Edwards, J. Serbst, and D. Hansen. 1996. Predicting the toxicity of silver-spiked sediments using interstitial water metal and acid volatile sulfide normalization. In *Abstract Book, SETAC 17th Annual Meeting*, sponsored by the Society of Environmental Toxicology and Chemistry, Washington, DC, November 17-21, 1996.
- Bilyard, G.R. 1987. The value of benthic infauna in marine pollution monitoring studies. *Mar. Poll. Bull.* 18:581-585.
- Bondelid, T.R., and S.A. Hanson. 1990. Technical description of the Reach File. Prepared for U.S. Environmental Protection Agency, Assessment and Watershed Protection Division, Washington, DC.
- Bopp, R.F., M.L. Gross, H. Tong, H.J. Simpson, S.J. Monson, B.L. Deck, and F.C. Moser. 1991. A major incident of dioxin contamination: Sediments of New Jersey estuaries. *Environ. Sci. Technol.* 25(5): 951-956.
- Bopp, R.F., H.J. Simpson, S.N. Chillrud, and D.W. Robinson. 1993. Sediment derived chronologies of persistent contaminants in Jamaica Bay, New York. *Estuaries* 16(3B): 608-616.
- Bricker, S.B. 1993. Historical trends in contamination of estuarine and coastal sediments: The history of Cu, Pb, and Zn inputs to Narragansett Bay, Rhode Island as recorded by salt marsh sediments. *Estuaries* 16(3B):589-607.
- Brown, R.C., R.H. Pierce, and S.A. Rice. 1985. Hydrocarbon contamination in sediments from urban stormwater runoff. *Mar. Poll. Bull.* 16(6):236-240.

- Burton, G.A., Jr., B.L. Stemmer, K.L. Winks, P.E. Ross, and L.C. Burnett. 1989. A multitrophic level evaluation of sediment toxicity in Waukegan and Indiana harbors. *Environ. Toxicol. Chem.* 8:1057-1066.
- Canfield, T.J., N.E. Kemble, W.G. Brumbaugh, F.J. Dwyer, C.G. Ingersoll, and F.J. Fairchild. 1994. Use of benthic invertebrate community structure and the sediment quality triad to evaluate metal-contaminated sediment in the Upper Clark Fork River, Montana. *Environ. Toxicol. Chem.* 13:1999-2012.
- Clarke, J.U., and V.A. McFarland. 1991. *Assessing bioaccumulation in aquatic organisms exposed to contaminated sediments*. Long-Term Effects of Dredging Operations Program, misc. pap. D-91-2. U.S. Army Corps of Engineers, Waterways Experiment Station, Vicksburg, MS.
- Cohn-Lee, R., and D. Cameron. 1991. *Poison runoff in the Atlanta Region*. Natural Resources Defense Council, Washington, DC.
- Crawford, D.W., N.L. Bonnevie, and R.J. Wenning. 1995. Sources of pollution and sediment contamination in Newark Bay, New Jersey. *Ecotoxicol. Environ. Saf.* 30(1): 85-100.
- Dexter, R.N., D.E. Anderson, E.A. Quinlan, L.S. Goldstein, R.M. Strickland, R.M. Kocan, M. Landolt, J.P. Pavlou, and V.R. Clayton. 1981. *A summary of knowledge of Puget Sound*. NOAA tech. mem. OMPA-13. National Oceanic and Atmospheric Administration, Washington, DC.
- Di Toro, D.M., J.D. Mahony, D.J. Hansen, K.J. Scott, M.B. Hicks, S.M. Mays, and M.S. Redmond. 1990. Toxicity of cadmium in sediments: The role of acid volatile sulfide. *Environ. Toxicol. Chem.* 9:1487-1502.
- Di Toro, D.M., J.D. Mahony, D.J. Hansen, K.J. Scott, A.R. Carlson, and G.T. Ankley. 1992. Acid volatile sulfide predicts the acute toxicity of cadmium and nickel in sediments. *Environ. Sci. Technol.* 26(1):96-101.
- Eisler, R. 1995. Electroplating wastes in marine environments. A case history at Quonset Point, Rhode Island. In *Handbook of ecotoxicology*, ed. D.J. Hoffman, B.A. Rattner, G.A. Burton, Jr., and J. Cairns, Jr., pp. 609-630. Lewis Publishers, Boca Raton, FL.
- FDEP. 1994. *Approach to the assessment of sediment quality in Florida coastal water. Vol. 1. Development and evaluation of sediment quality assessment guidelines*. Prepared for Florida Department of Environmental Protection, Office of Water Policy, Tallahassee, FL, by MacDonald Environmental Sciences Ltd., Ladysmith, British Columbia.
- Fox, R.G., and M. Tuchman. 1996. The assessment and remediation of contaminated sediments (ARCS) program. *J. Great Lakes Res.* 22:493-494.
- Garton, L.S., J.S. Bonner, A.N. Ernest, and R.L. Autenrieth. 1996. Fate and transport of PCBs at the New Bedford Harbor Superfund site. *Environ. Toxicol. Chem.* 15(5): 736-745.
- Gilliom, R.J., and D.G. Clifton. 1990. Organochlorine pesticide residues in bed sediments of the San Joaquin River, California. *Water Res. Bull.* 26(1):11-24.
- Ginn, T.C., and R.A. Pastorok. 1982. Assessment and management of contaminated sediments in Puget Sound. In *Sediment toxicity assessment*, ed. G.A. Burton, Jr., pp. 371-397. Lewis Publishers, Chelsea, MI.
- Hansen, D.J., 1995. Assessment tools that can be used for the National Sediment Inventory. Memorandum from D.J. Hansen, Environmental Research Laboratory, Narragansett, to C. Fox, USEPA Office of Water, February 28, 1995.
- Hansen, D.J., W.J. Berry, J.D. Mahoney, W.S. Boothman, D.M. DiToro, D.L. Robson, G.T. Ankley, D. Ma, Q. Yan, and C.E. Pesch. 1996. Predicting the toxicity of metal-contaminated field sediments using interstitial concentrations of metals and acid-volatile sulfide normalizations. *Environ. Toxicol. Chem.* 15(12): 2080-2094.
- Helfrich, J., and D.E. Armstrong. 1986. Polycyclic aromatic hydrocarbons in sediments of the southern basin of Lake Michigan. *J. Great Lakes Res.* 12(3):192-199.
- Henny, C.J., L.J. Blus, D.J. Hoffman, and R.A. Grove. 1994. Lead in hawks, falcons and owls downstream from a mining site on the Coeur d'Alene River, Idaho. *Environ. Monit. Assess.* 29(3):267-288.
- Hoffman, E.J. 1985. Urban runoff pollutant inputs to Narragansett Bay: Comparison to point sources. In *Proc. Perspectives on Nonpoint Source Pollution*,

- sponsored by U.S. Environmental Protection Agency, Kansas City, Missouri, May 19-22, pp. 159-164. EPA 440/5-85-001.
- Horowitz, A.J., K.A. Elrick, and R.B. Cook. 1993. Effect of mining and related activities on the sediment trace element geochemistry of Lake Coeur d'Alene, Idaho, USA. Part 1: Surface sediments. *Hydrol. Processes* 7(4):403-423.
- Huggett, R.J., and J.M. O'Connor. 1988. Aquatic pollution problems, North Atlantic Coast, including Chesapeake Bay. *Aquat. Toxicol.* 11:163-190.
- IJC. 1987. *Guidance on characterization of toxic substances problems in areas of concern in the Great Lakes Basin*. International Joint Commission, Surveillance Work Group, Windsor, Ontario.
- Ingersoll, C.G., P.S. Haverland, E.L. Brunson, T.J. Canfield, F.J. Dwyer, C.E. Henke, and N.E. Kemble. 1996. Calculation and evaluation of sediment effect concentrations. *J. Great Lakes Res.* 22:602-623.
- Ingersoll, C.G., G.R. Biddinger, and T. Dillon (editors). 1997. *Ecological risk assessments of contaminated sediments*. SETAC Press, Pensacola, FL: In press.
- Johnson, N.D., M.T. Scholtz, V. Cassaday, K. Davidson, and D. Ord. 1992. *MOE toxic chemical emission inventory for Ontario and eastern North America*. Report no. P92-T61-5429/OG. Final report to the Air Resources Branch, Ontario Ministry of the Environment, prepared by Ortech International.
- Keeler, G.J. 1994. *Lake Michigan Urban Air Toxics Study*. U.S. Environmental Protection Agency, Office of Research and Development, Atmospheric Research and Exposure Assessment Laboratory, Research Triangle Park, NC. Cited in USEPA, 1994a.
- Keeler, G.J., J.M. Pacyna, T.F. Bidleman, and J.O. Nriagu. 1993. *Identification of sources contributing to the contamination of the great waters by toxic compounds*. Prepared for U.S. Environmental Protection Agency, Office of Air Quality Planning and Standards, Pollution Assessment Branch, Durham, NC.
- Kennicutt, M.C., T.L. Wade, B.J. Presley, A.G. Requejo, J.M. Brooks, and G.J. Denoux. 1994. Sediment contaminants in Casco Bay, Maine: Inventories, sources, and potential for biological impact. *Environ. Sci. Technol.* 28(1):1-15.
- Kleinman, R.L.P. 1989. Acid mine drainage. U.S. Bureau of Mines researches and develops control methods for both coal and metal mines. *Energ. Min. J.* 161-16N.
- Kubiak, T.J., H.J. Harris, L.M. Smith, T.R. Schwartz, D.L. Stalling, J.A. Trick, L. Sileo, D.E. Docherty, and T.C. Erdman. 1989. Microcontaminants and reproductive impairment of the Forster's tern on Green Bay, Lake Michigan. 1983. *Arch. Environ. Contam. Toxicol.* 18:706-727.
- Lake, J.L., R.J. Pruell, and F.A. Osterman. 1992. An examination of dechlorination processes and pathways in New Bedford Harbor sediments. *Mar. Environ. Res.* 33(1): 31-47.
- Landis, W.G., and M-H. Yu. 1995. *Introduction to environmental toxicology: Impacts of chemicals upon ecological systems*. Lewis Publishers, Boca Raton, FL.
- Leigh, D.S. 1994. Mercury contamination and floodplain sedimentation from former gold mines in north Georgia. *Water Res. Bull.* 30(4):739-748.
- Livingston, E.H., and J.H. Cox. 1985. Urban stormwater quality management: The Florida experience. In *Proc. Perspectives on Nonpoint Source Pollution*, sponsored by U.S. Environmental Protection Agency, Kansas City, Missouri, May 19-22, pp. 289-291. EPA 440/5-85-001.
- Long, E.R. 1982. An assessment of marine pollution in Puget Sound. *Mar. Pollut. Bull.* 13:380-383.
- Long, E.R., L.J. Field, and D.D. MacDonald. Predicting toxicity in marine sediments with numerical sediment guidelines. Submitted to *Environ. Toxicol. Chem.*
- Long, E.R., D.D. MacDonald, S.L. Smith, and F.D. Calder. 1995. Incidence of adverse biological effects within ranges of chemical concentrations in marine and estuarine sediments. *Environ. Manage.* 19(1):81-97.
- Long, E.R., A. Robertson, D.A. Wolfe, I. Hameedi, and G.M. Sloane. 1996. Estimates of the spatial extent of sediment toxicity in major U. S. estuaries. *ES&T*. 30(12): 3585-3592
- Long, E.R., and L.G. Morgan. 1990. *The potential for biological effects of sediment sorbed contaminants tested in the National Status and Trends Program*.

References

- NOAA tech. mem. NOA OMA 52. National Oceanic and Atmospheric Administration, Seattle, WA.
- Luoma, S.N. 1983. Bioavailability of trace metals to aquatic organisms—A review. *Sci. Tot. Environ.* 28:1-22.
- Lyman, W.J., A.E. Glazer, J.H. Ong, and S.F. Coons. 1987. *An overview of sediment quality in the United States*. Prepared for U.S. Environmental Protection Agency, Office of Water Regulations and Standards, Washington, DC.
- Malins, D.C., B.B. McCain, D.W. Brown, A.K. Sparks, and H.O. Hodgins. 1980. *Chemical contaminants and biological abnormalities in central and southern Puget Sound*. NOAA tech. mem. OMPA-2. National Oceanic and Atmospheric Administration, Washington, DC.
- Mancini, J.L., and A.H. Plummer, Jr. 1994. A review of EPA sediment criteria. Proceedings of the Water Environment Federation, 67th Annual Conference and Exposition, October 15-19, Chicago, IL. In *Surface quality ecology*, Vol. 4, pp. 681-694.
- Mastran, T.A., A.M. Dietrich, D.L. Gallagher, and T.J. Grizzard. 1994. Distribution of polyaromatic hydrocarbons in the water column and sediments of a drinking water reservoir with respect to boating activity. *Water Res.* 28(11):2353-2366.
- Meyer, J.S., W. Davison, B. Sundby, J.T. Ores, D.J. Lauren, U. Forstner, J. Hong, and D.G. Crosby. 1994. Synopsis of discussion session: The effects of variable redox potentials, pH, and light on bioavailability in dynamic water-sediment environments. In *Bioavailability physical, chemical, and biological interactions*, proceedings of the Thirteenth Pellston Workshop, ed. J.L. Hamelink, P.F. Landrum, H.L. Bergman, and W.H. Benson, pp. 155-170. Lewis Publishers, Boca Raton, FL.
- Moore, J.N., S.N. Luoma, and D. Peters. 1991. Downstream effects of mine effluent on an intermontane riparian system. *Can. J. Fish. Aquat. Sci.* 48(2):222-232.
- Myers, M.S., C.M. Stehr, O.P. Olsen, L.L. Johnson, B.B. McCain, S-L Chan, and U. Varansi. 1994. Relationships between toxicopathic hepatic lesions and exposure to chemical contaminants in English sole (*Pleuronectes vetulus*), starry flounder (*Platichthys stellatus*), and white croaker (*Genyonemus lineatus*) from selected marine sites on the Pacific Coast, USA. *Envir. Health Perspect.* 102(2):200-215.
- Nichols, M.M. 1990. Sedimentologic rate and cycling of kepone in an estuarine system: Example from the James River Estuary. *Sci. Tot. Environ.* 97-98:407-440.
- NOAA. 1994. *Inventory of chemical concentrations in coastal and estuarine sediments*. NOAA tech. mem. NOS ORCA 76. National Oceanic and Atmospheric Administration, National Ocean Service, Silver Spring, MD.
- NRC (National Research Council). 1989. *Contaminated marine sediments—Assessment and remediation*. National Academy Press, Washington, DC.
- Pereira, W.E., F.D. Hostettler, and R.B. Rapp. 1994. Bioaccumulation of hydrocarbons derived from terrestrial and anthropogenic sources in the Asian clam, *Potamocorbula amurensis*, in San Francisco Bay Estuary. *Mar. Poll. Bull.* 24(2):103-109.
- Pitt, R.E. 1995. Effects of urban runoff on aquatic biota. In *Handbook of ecotoxicology*, ed. D.J. Hoffman, B.A. Ratner, G.A. Burton, Jr., and J. Cairns, Jr., pp. 609-630. Lewis Publishers, Boca Raton, FL.
- Power, E.A., and P.M. Chapmann. 1992. Assessing sediment quality. In *Sediment toxicity assessment*, ed. G.A. Burton, Jr. Lewis Publishers, Ann Arbor, MI.
- Prahl, F.G., E. Crecellus, and R. Carpenter. 1984. Polycyclic aromatic hydrocarbons in Washington coastal sediments: An evaluation of atmospheric and riverine routes of introduction. *Environ. Sci. Technol.* 18:687-693.
- Rand, G.M., and S.R. Petrocelli. 1985. *Fundamentals of aquatic toxicology*. Hemisphere Publishing Corp., New York, NY.
- Rice, D.W., S.P. Seltnerich, R.B. Spies, and M.L. Keller. 1993. Seasonal and annual distribution of organic contaminants in marine sediments from Elkhorn Slough, Moss Landing Harbor and Nearshore Monterey Bay, California. *Environ. Pollut.* 82:79-91.
- Riley, R.G., E.A. Crecelius, M.L. O'Malley, K.H. Abel, and D.C. Mann. 1981. *Organic pollutants in waterways adjacent to Commencement Bay (Puget Sound)*. NOAA tech. mem. OMPA-12. National Oceanic and Atmospheric Administration, Rockville, MD.

- Ryan, J., and J.H. Cox. 1985. The influence of NPS pollution in Florida estuaries: A case study. In *Proc. Perspectives on Nonpoint Source Pollution*, sponsored by U.S. Environmental Protection Agency, Kansas City, Missouri, May 19-22, pp. 172-179. EPA 440/5-85-001.
- SAB. 1989. *Review of the apparent effects threshold approach to setting sediment criteria*. Report of the Science Advisory Board, Sediment Criteria Subcommittee, U.S. Environmental Protection Agency, Washington, DC.
- Salomons, W., N.M. de Rooji, H. Kerdijk, and J. Bril. 1987. Sediment as a source for contaminants? *Hydrobiologia* 149:13-30.
- Schueler, T. Fall 1995. Urban pesticides: From the lawn to the stream. *Watersh. Prot. Tech.* 2(1):247-253.
- Schueler, T.R. Summer 1994. Pollutant dynamics of pond muck. *Watersh. Prot. Tech.* 1(2):39-46.
- Sorensen, J.A., G.E. Glass, K.W. Schmidt, J.K. Huber, and G.R. Rapp, Jr. 1990. Airborne mercury deposition and watershed characteristics in relation to mercury concentrations in water, sediments, plankton, and fish of eighty northern Minnesota lakes. *Environ. Sci. Technol.* 24(11):1716-1727.
- Swartz, R.C., W.A. Deben, K.A. Sercu, and J.O. Lamberson. 1982. Sediment toxicity and distribution of amphipods in Commencement Bay, Washington, USA. *Mar. Poll. Bull.* 13:359-364.
- Swartz, R.C., D.W. Schults, J.O. Lamberson, R.J. Ozretich, and J.K. Stull. 1991. Vertical profiles of toxicity, organic carbon, and chemical contaminants in sediment cores from the Palos Verdes Shelf and Santa Monica Bay, California. *Mar. Environ. Res.* 31:215-225.
- Swartz, R.C., D.W. Schults, R.J. Ozretich, J.O. Lamberson, F.A. Cole, T.H. DeWitt, M.S. Redmond, and S.P. Ferraro. 1995. PAH: A model to predict the toxicity of polynuclear aromatic hydrocarbon mixtures in field-collected sediments. *Environ. Toxicol. Chem.* 14(11): 1977-1987.
- USEPA. 1987. *An overview of sediment quality in the United States*. EPA-905/9-88-002. U.S. Environmental Protection Agency, Office of Water, Washington, DC.
- . 1992a. *Proceedings of EPA's contaminated sediment management strategy forums*. Chicago, IL, April 21-22; Washington, DC, May 27-28 and June 16, 1992. EPA 823-R-92-007.
- . 1992b. *Environmental impacts of stormwater discharges: A national profile*. U.S. Environmental Protection Agency, Office of Water, Washington, DC.
- . 1993a. *Framework for the development of the National Sediment Inventory*. U.S. Environmental Protection Agency, Office of Science and Technology, Washington, DC.
- . 1993b. *Guidelines for deriving site-specific sediment quality criteria for the protection of benthic organisms*. EPA-822-R-93-017. U.S. Environmental Protection Agency, Office of Science and Technology, Health and Ecological Criteria Division, Washington, DC.
- . 1993c. *Identification of sources contributing to the contamination of the great waters by toxic compounds*. U.S. Environmental Protection Agency, Office of Planning and Standards, Durham, NC.
- . 1993d. *Technical basis for establishing sediment quality criteria for nonionic organic contaminants for the protection of benthic organisms by using equilibrium partitioning*. Draft. EPA 822-R-93-011. U.S. Environmental Protection Agency, Office of Science and Technology, Health and Ecological Criteria Division, Washington, DC.
- . 1994a. *Deposition of air pollutants to the great waters*. U.S. Environmental Protection Agency, Office of Air Quality, Research Triangle Park, NC.
- . 1994b. *Methods for assessing the toxicity of sediment-associated contaminants with estuarine and marine amphipods*. EPA 600-R-94-025. U.S. Environmental Protection Agency, Office of Research and Development, Washington, DC.
- . 1994c. *Methods for measuring the toxicity and bioaccumulation of sediment-associated contaminants with fresh water invertebrates*. EPA 600/R-94/024, Environmental Protection Agency, Duluth, MN.
- . 1994d. *Proceedings of the National Sediment Inventory Workshop; April 26-27, 1994, Washington, DC*. U.S. Environmental Protection Agency, Office of Science and Technology, Washington, DC.

- . 1994e. *National water quality inventory: 1992 report to Congress*. EPA-841-R-94-001. U.S. Environmental Protection Agency, Office of Water, Washington, DC.
- . 1994f. *Guidance for assessing chemical contamination data for use in fish advisories, Vol. II: Risk assessment and fish consumption limits*. EPA 823-B-94-004, U.S. Environmental Protection Agency, Office of Water, Washington, DC.
- . 1994g. *The Watershed Protection Approach: 1993/94 Activity Report*. EPA 840-S-94-001. U.S. Environmental Protection Agency, Office of Water, Washington, DC.
- . 1995a. *Great Lakes Water Quality Initiative criteria documents for the protection of wildlife*. EPA-820-B-95-008. U.S. Environmental Protection Agency, Office of Science and Technology, Washington, DC.
- . 1995b. *A Phase I Inventory of Current EPA Efforts to Protect Ecosystems*. EPA 841-S-95-001. U.S. Environmental Protection Agency, Office of Water, Washington, DC.
- . 1995c. *Guidance for Assessing Chemical Contaminant Data for Use in Fish Advisories, Volume 1: Fish Sampling and Analysis* (Second Edition). EPA 823-R-95007, U.S. Environmental Protection Agency, Office of Water, Washington, DC.
- . 1996. *Derivation of EPA's Sediment Quality Advisory Levels (DRAFT)*. U.S. Environmental Protection Agency, Office of Science and Technology, Washington, DC.
- USGS. 1993. *Persistence of the DDT pesticide in the Yakima River Basin Washington*. USGS circular 1090. U.S. Geological Survey, Denver, CO.
- Van Veld, P.A., D.J. Westbrook, B.R. Woodin, R.C. Hale, C.L. Smith, R.J. Hugget, and J.J. Stegman. 1990. Induced cytochrome P-450 in intestine and liver of spot (*Leiostomus xanthurus*) from a polycyclic aromatic contaminated environment. *Aquat. Toxicol.* 17:119-132.
- Voldner, E.C. and L. Smith. (1989). Production, usage, and emissions of fourteen priority toxic chemicals. Appendix 2 to the *Proceedings of the Workshop on the Estimation of Atmospheric Chemicals to the Great Lakes Basin*. Scarborough, Ontario, Joint Water Quality Board/Science Advisory Board/International Air Quality Advisory Board of the International Joint Commission Windsor, Ontario, ISBN 1-895085-20-9, 94 pp.
- Wenning, R.J., N.L. Bonnevie, and S.L. Huntley. 1994. Accumulation of metals, polychlorinated biphenyls, and polycyclic aromatic hydrocarbons in sediments from the lower Passaic River, New Jersey. *Arch. Environ. Contam. Toxicol.* 27(1):64-81.
- Willis, G.H., and L.L. McDowell. 1983. Environmental chemistry review: Pesticides in agricultural runoff and their effects on downstream water quality. *Environ. Toxicol. Chem.* 1:267-279.
- Yousef, Y.A., H.H. Harper, L. Wiseman, and M. Bateman. 1985. *Consequential species of heavy metals*. FL-ER-29-85. University of Central Florida, Department of Civil Engineering and Environmental Sciences. Sponsored by the Florida Department of Transportation.

Appendix A

Detailed Description of NSI Data

Sources of the NSI Data

The scope of the data compilation component of the NSI was to collect, review, and compile readily available data that could be used to evaluate the incidence of sediment contamination throughout the United States. As a result, emphasis was placed on gathering data sets with sediment chemistry data since those were the most prevalent data available on a national basis. The minimum data elements for inclusion in the NSI were date of sample collection, latitude/longitude, reliable units (e.g., mg/kg), and source of data. The electronic data sources used for the NSI are listed below.

- EPA's Storage and Retrieval System (STORET)
- EPA's Ocean Data Evaluation System (ODES)
- NOAA's Coastal Sediment Inventory (COSED)
- EPA Region 4's Sediment Quality Inventory
- EPA Gulf of Mexico Program's Contaminated Sediment Inventory
- EPA Region 10/COE Seattle District Sediment Inventory
- EPA's Great Lakes Data Base
- EPA's Environmental Monitoring and Assessment Program (EMAP)
- EPA Region 9 Dredged Material Tracking System (DMATS)
- USGS Massachusetts Bay Data (metals only)
- National Source Inventory (PCS and TRI)

In several cases, the readily available data sources for the NSI were compilations of existing data. For example, the EPA Gulf of Mexico Program's Contaminated Sediment Inventory included data from ODES, STORET, and EMAP. Since those data sources had been reviewed independently, they were deleted from the Gulf of Mexico Inventory before that data set was added to the NSI. A similar screening of data was conducted for the other data sets included in the NSI. Below is a summary of the remaining contributors to the individual data sets:

STORET	Numerous federal and state agencies	
ODES	Boston Harbor	Tennessee
	Massachusetts Bay	Kentucky
	Cape Arundel	Florida
	City of Gloucester	GLNPO/ARCS
	Mile 106	Galveston Bay
	South Carolina	San Diego Pre-301(h)
	Alabama	Orange County 301(h)
	Mississippi	Oxnard 301(h)
	Georgia	Los Angeles 301(h)
	North Carolina	Thums Ocean Dumping
	Encina 301(h)	Puget Sound
	Morro Bay 301(h)	Anchorage
	Hyperion 301(h)	Endicott 403(c)

	Goleta 301(h) San Francisco NEP LA2 Ocean Dumping LA5 Ocean Dumping	Kuparuk STP 403(c) Prudhoe Bay 403(c) Port Valdez 403(c)
COSED	NOAA NS&T	Ed Long
Region 4	City of Tampa Dept of Navy EPA Region 4 Florida DER South Florida Water Mgmt Dist. USACE	USACE, Jacksonville USACE, Mobile USACE, Savannah USACE, Wilmington USFWS
Gulf of Mexico	ADEM (Mobile) Army Corps Eng. EPA-Houston ERL-N GCRL, Mississippi	TVA USACE (Mobile) USEPA Region 6 USGS
Seattle COE	Department of Social and Health Services Department of Ecology U.S. Fish and Wildlife Service Puget Sound Water Quality Authority Tetra Tech, Inc. Department of Fisheries Department of Natural Resources Department of Wildlife EPA Region 10 Batelle Northwest Sequim Laboratory Environmental Systems Corporation Department of Health College of Ocean and Fisheries Science PTI Environmental Services National Oceanic and Atmospheric Admin. Fish and Wildlife Health Consultants City of Bellingham U.S. Army Corps of Engineers, Seattle Columbia Northwest, Inc. Hulbert Mill King County Municipality of Metropolitan Seattle Wildlife Health Consultants U.S. Navy City of Olympia, LOTT treatment plant Port of Bellingham Port of Everett Port of Olympia Port of Port Townsend Thurston County Dept of Public Health U.S. Coast Guard	Department of Parks and Recreation Environmental Information Consultants South. CA Coastal Water Research Proj., Army Corps of Engineers, San Francisco Environmental Science Associates, Inc. E.V.S. Consultants, Sausalito, CA Marine Bioassay Labs, Watsonville, CA MEC Analytical Systems, Watsonville, CA San Francisco Port Commission ToxScan, Inc., Watsonville, CA Tetra Tech, Inc., Lafayette, CA Port of Grays Harbor Port of Tacoma Tristar Marine Morton Marine Port of Seattle South Park Marina U.S. Oil and Refining Company Weyerhaeuser Day Island Yacht Club Shell Oil Capital Regional District, Victoria, BC Environment Canada Greater Vancouver Regional District E.V.S. Consultants, Seattle, WA E.V.S. Consultants, Vancouver, BC British Petroleum Oil Company American Petroleum Institute
Great Lakes	Heidelberg College, Tiffin, Ohio Illinois EPA Michigan Tech. Univ., Houghton, MI	US Army COE, Buffalo District Beak Consultants, Inc Ontario Ministry of the Environment

	Univ. of Wisconsin-Superior, WI Michigan Dept. Natural Resources Ohio EPA Illinois Geological Survey USEPA-GLNPO USEPA-ERL-Duluth	Aqua Tech, Melmore, OHEG&G Bionomics/Aqua Tech Environ. Cnslt. Applied Biology, Inc., Decatur, GA Recra Research, Inc., Tonawanda, NY USFWS, Columbia, MO - ARCS Michigan State University
EMAP	Louisianian Province	Virginian Province
DMATS	USEPA Region 9	
USGS Massachusetts Bay	A.D. Little, 1990 ACE_NED permit file #29-91-00473E ACE_NED permit file 199102068 ACE_NED permit file 09-89-2777 ACE_NED permit file 09-89-530 ACE_NED permit file 1989-2911 ACE_NED permit file 199101096 ACE_NED permit file 20-87-2002 ACE_NED permit file 20-89-2206 ACE_NED permit file 22-87-927 ACE_NED permit file 23-198902070 ACE_NED permit file 24-87-912 ACE_NED permit file 24-89-1180 ACE_NED permit file 25-81-374 ACE_NED permit file 25-86-1007 ACE_NED permit file 25-86-290E ACE_NED permit file 25-86-641 ACE_NED permit file Boston Harbor ACE_NED permit file Bridge marine- Salisbury, MA ACE_NED permit file CENED-OR (1145-2-303b) ACE_NED permit file HULL-72-CHA30 ACE_NED permit file Long Wharf Boston	ACE_NED permit file Navigation Improvement Study Feasibility Report and Environmental Assessment; Mystic RI ACE_NED permit file Navigation Improvement Study Dredge Material Disposal Plan Supplement to Feasibility Rep Boehm, 1983 Bajek, 1983 Battelle, 1984; 1987 a, b Boehm & Farrington, 1984 Boehm et al., 1984 CDM, 1980 Cudmore, 1988 Enseco, 1987a Enseco, 1987b GCA Corp., 1982 Gardner et al., 1986 Gardner et al., 1988 Hubbard, 1987 Jason M. Cortell & Assoc., 1982
USGS Massachusetts Bay	ACE_NED permit file MA DPW Beverly-Salem Bridge and By-Pass Project ACE_NED permit file MA-HULL-81-180 ACE_NED permit file MA-HULL-84-210 ACE_NED permit file MWRA- Stoney Brook Conduit ACE_NED permit file Massport Bird Island Flats - Harborwalk phase III ACE_NED permit file Navigation Improvement Study Dredge Material Disposal Plan Supplement to Feasibility Rep USACOE, 1981 Wong, 1983 USEPA MBDS, 1989 USACOE, 1990b (DAMOS)	Jason Cortell, 1990 MA DEQE, 1985 MA DEQE, 1986 MA DPW, 1991 MA DEQE, 1982 MacDonald, 1991 NET Atlantic, 1990 Nolan et al., 1981 Penney et al., 1981 Phillips, 1985 Pruell et al., 1989 Ryan et al., 1982 Robinson et al., 1990 Shea et al., 1991 Shiaris et al., 1986

Types of Data Included in the NSI

In addition to sediment chemistry data, tissue residue, benthic abundance, toxicity (solid-phase and elutriate), histopathology, and fish abundance data have been gathered and included in the NSI, although only the sediment chemistry, tissue residue, and toxicity data have been evaluated for this report to Congress. The NSI also includes

loadings data from the Permit Compliance System (PCS) and the Toxic Release Inventory (TRI). A summary of the types of data available in the NSI is provided below.

Sediment chemistry. Sediment chemistry data include detailed analytical results, analyte sampled, remark codes, sampling methods, analytical methods, sample weight, core depths, and grain size information. Percent organic carbon and acid-volatile sulfide content of sediments are also included when available.

Tissue residue. Tissue residue data include detailed analytical results, analyte sampled, remark codes, sampling methods, clean-up procedures, analytical methods, species, sex, anatomy sampled, life stage, and wet/dry reporting basis.

Toxicity. Toxicity data include test conditions (DO, pH, flushing hardness, feeding, salinity, etc.), test species, dilution, endpoints (e.g., mortality), and test duration. Solid-phase and elutriate data are provided when available.

Benthic abundance. Benthic abundance data include enumeration of species collected and numerous community-level summaries/indices.

Histopathology. Histopathology data include the number of fish with body, branchial, and buccal pathologies; number of species; and abundance.

Fish abundance. Fish abundance data include mean and standard deviation of fish length and abundance of species.

For each data set included in the NSI, Table A-1 identifies the number of sampling stations at which the following parameters were measured:

- Sediment chemistry
- Tissue residue
- Benthic abundance
- Toxicity
- Histopathology
- Matched data
 - sediment chemistry and tissue residue
 - sediment chemistry and benthic abundance
 - sediment chemistry and toxicity
 - sediment chemistry and histopathology
 - sediment chemistry, tissue residue, and toxicity
 - sediment chemistry, benthic abundance, and toxicity

Table A-2 presents the total number of sampling stations at which each of these parameters was measured and the number of sampling stations for which coordinates (i.e., latitude/longitude) were available. Only data from sampling stations with coordinates could be used to classify sampling stations into Tier 1, Tier 2, or Tier 3.

How the Data Are Organized

The NSI data are contained in a series of tables that correspond to the different types of data described above. In some cases multiple tables were created for one type of data. The primary table in the NSI is the station table. Each record in the table corresponds to a unique sampling station. The records in the station table can be related to tables for each type of data, such as sediment chemistry data, tissue residue data, etc. These tables can then be related to additional look-up tables that include ancillary information such as chemical or species names. Figure A-1 illustrates the relationship between the station, sediment chemistry, tissue residue, toxicity, and related look-up tables.

Table A-3 summarizes the tables available in version 1.1 of the NSI (the current version). Some of these tables have not required updating since version 1.0 of the NSI (the version used to prepare the preliminary

Table A-1. Number of Sampling Stations at Which Various Types of Data Were Collected

Data Set	Number of Stations Where Measured										
	Sediment Chemistry	Tissue Residue	Benthic Abundance	Toxicity	Histopathology	Sediment Chemistry and Tissue Residue	Sediment Chemistry and Benthic Abundance	Sediment Chemistry and Toxicity	Sediment Chemistry and Histopathology	Sediment Chemistry, Tissue Residue, and Toxicity	Sediment Chemistry, Benthic Abundance, and Toxicity
STORET	12,907	6,057				1,533					
Region 4	1,024										
ODES	1,317	1,722	2,592	296		37	664	70		2	49
COSED	1,104										
Gulf of Mexico	210			82				6			
Great Lakes	761	26	476	373		26	449	369		26	68
DMATS	213	202		245		169		188		163	
Mass. Bay	979										
EMAP LA Prov. VA Prov.	260 200	199	259 212	259 212	259	198	259 202	259 202	259	198	259 202
Seattle USCOE	2,116		365	876			365	707			270
Total	21,093	8,206	3,904	2,343	259	1,963	1,939	1,801	259	389	848

Table A-2. Number of Sampling Stations With Data Included in the NSI

Measurement Parameters	Total Number of Stations	Stations with Coordinates	
		Number	% of Total Number of Stations w/Coordinates ^a
Sediment Chemistry	21,093	19,546	76
TOC	6,170	5,335	21
AVS	425	371	1
Tissue Residue	8,206	7,208	28
Toxicity	2,343	1,523	6
Elutriate Phase	630	—	—
Solid Phase	1,865	—	—
Benthic Abundance	3,904	1,844	7
Histopathology	259	259	1
Sediment Chemistry & Tissue	1,963	1,930	8
Sediment Chemistry & Toxicity	1,801	1,263	5
Sediment Chemistry & Abundance	1,939	1,340	5
Sediment Chemistry & Histopathology	259	259	1
Sediment Chemistry, Tissue, & Toxicity	389	359	1
Sediment Chemistry, Toxicity, & Abundance	848	733	3

^aTotal number of stations with coordinates = 25,555.

evaluation of sediment chemistry data described in Chapter 2). Key changes to the data set from version 1.0 include the following:

- Inclusion of Regional/state review codes. (See data element NSIREVCD in tables ALLSEDI and ALLTISS.)
- Resolution of species codes for tissue residue data.
- Inclusion of biotoxicity control data for EMAP programs.
- Revised loadings data from Permit Compliance System (PCS) and Toxic Release Inventory (TRI). Facilities with no loadings data are included as a separate table.
- Inclusion of species information and toxicity phase for purposes of the NSI evaluation methodology.

The remainder of this section contains a listing of the field names and descriptions associated with each table in the NSI.

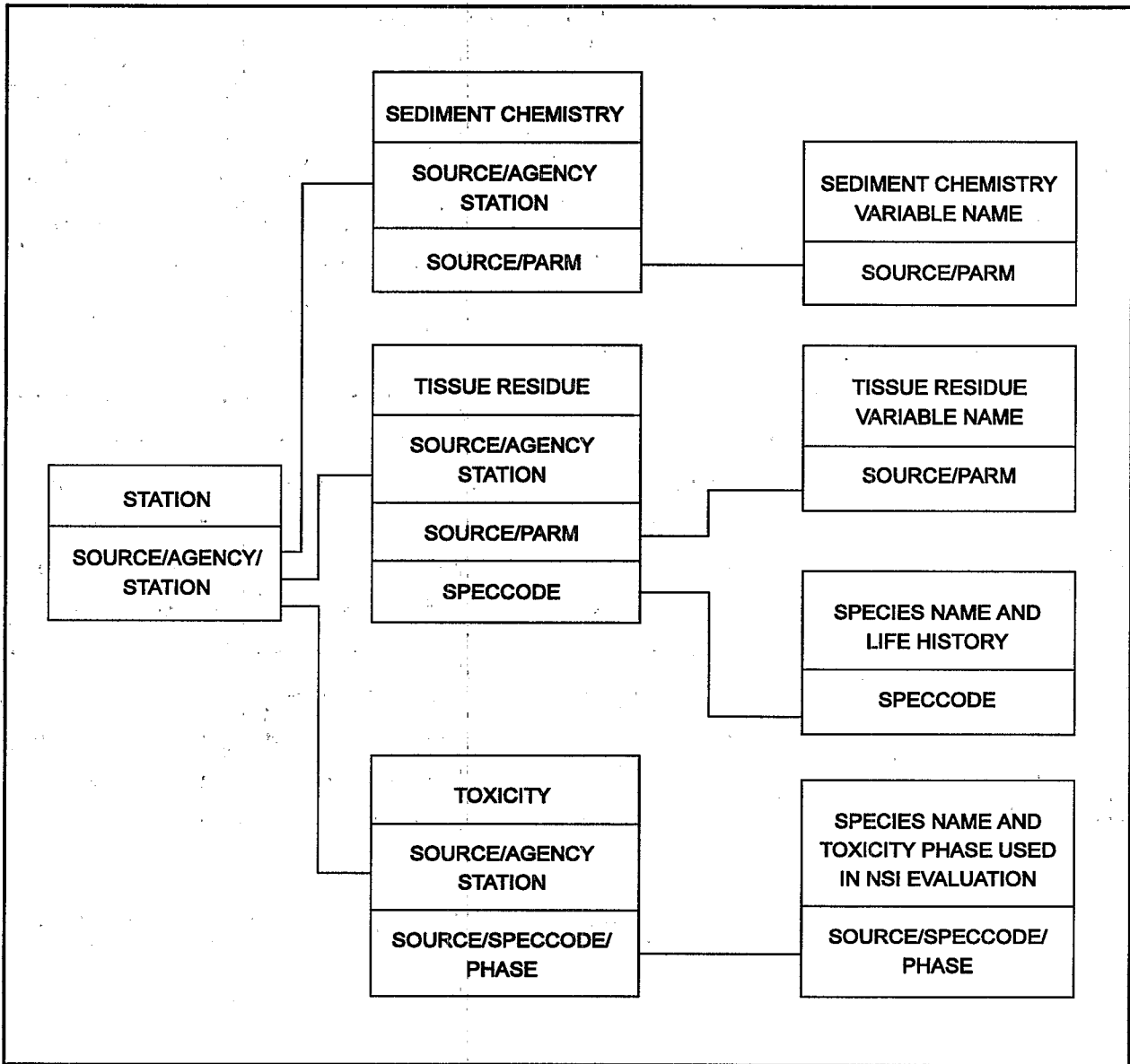

Figure A-1. Organization of NSI Data.

Table A-3. Data Tables Available in the NSI

Table Name	Table Description
ALLSTAT.DBF	Station
ALLSEDI.DBF	Sediment chemistry
ALLTISS.DBF	Tissue residue
ALLBIOT.DBF	Biotoxicity
ALLSEDM.DBF	Sediment grain size and miscellaneous sediment chemistry
ALLTISM.DBF	Miscellaneous tissue residue
ALLELUT.DBF	Elutriate
LOADD.DBF	PCS/TRI loadings
LOADS.DBF	PCS/TRI facilities (have loadings data)
LOADO.DBF	Other PCS/TRI facilities (no associated loadings data)
BIOTCODE.DBF	Toxicity phase for biotoxicity table (ALLBIOT)
ELUTPARM.DBF	List of analytes for elutriate table (ALLELUT)
SED_PARM.DBF	List of analytes for sediment tables (ALLSEDI, ALLSEDM)
TIS_CODE.DBF	List of species for tissue tables (ALLTISS, ALLTISM)
TIS_PARM.DBF	List of analytes for tissue tables (ALLTISS, ALLTISM)
SEACOE.DBF	EPA Region 10/COE Seattle District's Sediment Inventory Code file (important for interpreting a large number of codes unique to this data source)
REMARK.WP	Text file on remark codes (important for remark codes other than "K" or "U")
ALLSUPR.DBF	Superfund facilities
ALLBENA.DBF	Benthic species abundance
ALLBENC.DBF	Benthic community
ALLHIST.DBF	Histopathology
ALLFISA.DBF	Fish abundance
SPEC-CD.DBF	Species codes for benthic data
FISH-CD.DBF	Species codes for fish abundance data

ALLSTAT.DBF	Station
SOURCE	Identification of data origin (e.g., REG4 is the Region 4 Pilot Study)
AGENCY	Identification of group responsible for collecting data (e.g., NS&T is NOAA's National Status and Trends Program)
STATION	Monitoring station identification code. (ODES NOTE: STATION = <i>STN_CD</i> ' ' <i>STATION</i> DATE. DMATS NOTE: STATION = <i>ID</i> ' ' <i>STATIONI</i> ' ' <i>SERIES</i> ' ' <i>SCAN</i> .)
COUNTY	County
DEPTH	Water depth (m)
DEPT_MAX	Maximum water depth (m)
DEPT_MIN	Minimum water depth (m)
DREDGESI	Dredged site
DRWATERB	Dredged water body
GEOCODE	Geologic code
INSTIT	Institution
LAT	Latitude (decimal degrees)
LAT_2	Latitude #2 forming a rectangle (decimal degrees)
LNG	Longitude (decimal degrees)
LNG_2	Longitude #2 forming a rectangle (decimal degrees)
LOCATION	Location
LOC_CODE	Location code
NSIREACH	Reach File 1 reach
ORIGIN	Origin
ORG_NAME	Organization name
REFER	Reference, literature citation
SR_SCI	Senior scientist
STATE	State
WATERBOD	Waterbody
EPA_REG	EPA Region
FIPS	FIPS code
FIPS_DIS	Distance to nearest FIPS (mile)
HUC_DIS	Distance to nearest catologic unit (mile)
RF1_DIS	Distance to RF1 reach (mile)

ALLSEDI.DBF	Sediment chemistry
SOURCE	Identification of data origin (e.g., REG4 is the Region 4 Pilot Study)
AGENCY	Identification of group responsible for collecting data (e.g., NS&T is NOAA's National Status and Trends Program)
STATION	Monitoring station identification code. (ODES NOTE: STATION = <i>STN_CD</i> ' ' <i>STATION</i> DATE. DMATS NOTE: STATION = <i>ID</i> ' ' <i>STATIONI</i> ' ' <i>SERIES</i> ' ' <i>SCAN</i> .)
DATE	Date of sample collection
SAMPLE	Unique sample identifier code
SUBSAMPL	Unique subsample identifier code
REPLICAT	Unique replicate identifier code
SEQ	Computer-generated sequence number when multiple samples were taken; SOURCE, AGENCY, STATION, and DATE were identical; and no SAMPLE, SUBSAMPL, or REPLICAT codes were provided
CAS	CAS number for analyte
CLEANUP	Sample cleanup code to indicate an additional step taken to further purify the sample extracts or digestates
COMMENTS	Comments
DRY_WGT	Percent of total sample remaining after drying

EXT_MTHO	Extraction method code to indicate the method used to extract or digest the sample matrix and remove or isolate the chemical of concern
INSTRUME	Instrument code to identify the final chemical analysis method(s) used for analyzing the sample
MEAS_BAS	Result is wet or dry weight basis (see also P)
NSIREVCD	Preliminary evaluation code (A=Reviewed in QA/QC of Preliminary Evaluation, U=Only one (1) observation of this chemical in source, X=Deleted based on QA/QC of Preliminary Evaluation (first run), Y=Duplicate Data, Z=Deleted based on QA/QC of Preliminary Evaluation (second run))
P	Result associated with PARM ($\mu\text{g}/\text{kg}$, ppb)
PARM	Analyte measured (see also P and R)
R	Remark code associated with PARM and P
SAMP_DTL	Depth to bottom of sample interval (m)
SAMP_DTU	Depth to top of sample interval (m)
SMP_EQP	Sampling equipment code
SPHERE	Sphere (i.e., environment) code from which the sample came
WET_WGT	Total wet weight of sample (g)

ALLTISS.DBF	Tissue residue
SOURCE	Identification of data origin (e.g., REG4 is the Region 4 Pilot Study)
AGENCY	Identification of group responsible for collecting data (e.g., NS&T is NOAA's National Status and Trends Program)
STATION	Monitoring station identification code. (ODES NOTE: STATION = STN_CD ' ' STATION DATE. DMATS NOTE: STATION = ID ' ' STATION ' ' SERIES ' ' SCAN.)
DATE	Date of sample collection
SAMPLE	Unique sample identifier code
SEQ	Computer-generated sequence number when multiple samples were taken; SOURCE, AGENCY, STATION, and DATE were identical; and no SAMPLE, SUBSAMPL, or REPLICAT codes were provided
REPLICAT	Unique replicate identifier code
ANATOMY	Organ/tissue sampled
ANAT_CD	Organ/tissue sampled code
CAS	CAS number for analyte
CLEANUP	Sample cleanup code to indicate an additional step taken to further purify the sample extracts or digestates
COMPOSIT	A unique identifier to indicate a sample created by compositing tissues from several individuals
DRY_WGT	Percent of total sample remaining after drying
EXT_MTHO	Extraction method code to indicate the method used to extract or digest the sample matrix and remove or isolate the chemical of concern
INSTRUME	Instrument code to identify the final chemical analysis method(s) used for analyzing the sample
NSIREVCD	Preliminary evaluation code (F=Field test, L=Lab test, W=Species cannot be resolved, Y=Duplicate Data)
LENGTH	Length of specimen
LIFE_STA	Life stage code to identify the life stage of the sample
MEAS_BAS	Result is wet or dry weight basis (see also P)
NUMB_IND	Number of organisms in sample
P	Result associated with PARM
PARM	Analyte measured (see also P and R)
P_STD	Standard deviation of P associated with repeated measurements of PARM
R	Remark code associated with PARM and P

SAMPTYPE	Sample type
SEX	Sex code used to identify sex of sample
SMP_EQP	Sampling equipment code
SPECCODE	Species code
SPECIMEN	Unique identifier for the individual organism being analyzed
TOT_REP	Number of replicates
WEIGHT	Weight of organism
WET_WGT	Total weight of sample
LIPIDS	% Extractable lipids
SPEC_BIO	STORET taxonomic code

ALLBIOT.DBF	Biotoxicity
SOURCE	Identification of data origin (e.g., REG4 is the Region 4 Pilot Study)
AGENCY	Identification of group responsible for collecting data (e.g., NS&T is NOAA's National Status and Trends Program)
STATION	Monitoring station identification code. (ODES NOTE: STATION = STN_CD ' ' STATION DATE. DMATS NOTE: STATION = ID ' ' STATIONI ' ' SERIES ' ' SCAN.)
DATE	Date of sample collection
SAMPLE	Unique sample identifier code
REPLICAT	Unique replicate identifier code
SEQ	Computer-generated sequence number when multiple samples were taken; SOURCE, AGENCY, STATION, and DATE were identical; and no SAMPLE, SUBSAMPL, or REPLICAT codes were provided
AMMONIA	Ammonia concentration (mg/L)
ABNORMAL	Abnormality
BIOASS_DA	Bioassay date
BIOASSAY	Type of bioassay reported
BIOMASS	Biomass
COMMENTS	Comments
COM_NAME	Common name
DIL_UNIT	Concentration/Dilution units
DILUTION	Concentration/Dilution
DOX	Dissolved oxygen (mL/L)
ENDPOIN2	Endpoint #2 of bioassay test
ENDPOINT	Endpoint of bioassay test
E_QUALIF	EMERGENC qualifier
EMERGENC	Emergence after 10 days
EXT_MTHO	Extraction method code to indicate the method used to extract or digest the sample matrix and remove or isolate the chemical of concern
FEEDING	Feeding of species tested
FLUSH	Flushing rate in percent of chamber volume exchanged/24 hours
GENUS	Organism genus
HARDNESS	Hardness
HOLD_TIM	Holding time of sample prior to analysis (weeks)
LFSTG_EN	Life stage end—for bioassays that span more than one life stage, record predominant life stage at the end of the bioassay
LFSTG_ST	Life stage start—for bioassays that span more than one life stage, record predominant life stage at the start of the bioassay
MEASURED	Measured (Y/N)
NAME	Genus and species name (linked to PHASE)
NUM_ORGA	Number of organisms
P	Result associated with ENDPOINT

P_CC	Control-corrected analytical result associated with P
P2	Result associated with ENDPOIN2
PH	pH
PHASE	Phase code to indicate the phase (i.e., medium) in which the bioassay organisms are housed
PHOTO_PE	Photoperiod: Number of light hours vs. number of dark hours (e.g., 1608 = 16 hours light, 8 hours dark)
QASAMP1	Control sample no. 1
QASAMP2	Control sample no. 2
QASAMP3	Control sample no. 3
RENEWAL	Renewal (Y/N)
R	Remark code associated with ENDPOINT and P
REBURIAL	ET50 (mean reburial time)
RESPO_TY	Type of bioassay response
SALINITY	Salinity of water in test chamber (ppt)
SAMP_DTL	Depth to bottom of sample interval (m)
SAMP_DTU	Depth to top of sample interval (m)
SERIES	Bioassay series number
SIGNIF	Significant difference from control
SMP_EQP	Sampling equipment code
SPECCODE	Species code
SPECIES	Organism species
SPHERE	Sphere (i.e., environment) code from which the sample came
STD_TOX	Standard Toxicant Result code to indicate whether the results of the standard toxicant bioassay were acceptable
TEMP	Water temperature (deg C)
TESTDUR	Test duration (days)
TESTTYPE	Test used
TESTEXP	Test exposure periods
UNITS	Units associated with ENDPOINT and P
UNITS2	Units associated with ENDPOIN2 and P2
WATERTYP	Water type
YOUNG	Number of young produced per adult female over 4 weeks

ALLSEDM.DBF	Sediment grain size and miscellaneous sediment chemistry
SOURCE	Identification of data origin (e.g., REG4 is the Region 4 Pilot Study)
AGENCY	Identification of group responsible for collecting data (e.g., NS&T is NOAA's National Status and Trends Program)
STATION	Monitoring station identification code. (ODES NOTE: STATION = STN_CD ' ' STATION DATE. DMATS NOTE: STATION = ID ' ' STATION ' ' SERIES ' ' SCAN.)
DATE	Date of sample collection
SAMPLE	Unique sample identifier code
SUBSAMPL	Unique subsample identifier code
REPLICAT	Unique replicate identifier code
SEQ	Computer-generated sequence number when multiple samples were taken; SOURCE, AGENCY, STATION, and DATE were identical; and no SAMPLE, SUBSAMPL, or REPLICAT codes were provided
CAS	CAS number for analyte
CLEANUP	Sample cleanup code to indicate an additional step taken to further purify the sample extracts or digestates
COARSE_M	Method of analysis for analysis of coarse particles. Left blank if sample was not split into fractions.
COMMENTS	Comments

DRY_WGT	Percent of total sample remaining after drying
EXT_MTHO	Extraction method code to indicate the method used to extract or digest the sample matrix and remove or isolate the chemical of concern
FINE_MTH	Method of analysis for analysis of fine particles. Left blank if sample was not split into fractions.
INSTRUME	Instrument code to identify the final chemical analysis method(s) used for analyzing the sample
MEAS_BAS	Result is wet or dry weight basis (see also P)
P	Result associated with PARM
PARM	Analyte measured (see also P and R)
PHI_B	Phi boundaries in phi units, between the coarse and fine fractions
PHI_MAX	Phi boundary maximum at the fine end of the analyzed range
PHI_MIN	Phi boundary minimum at the coarse end of the analyzed range
R	Remark code associated with PARM and P
SAMP_DTL	Depth to bottom of sample interval (m)
SAMP_DTU	Depth to top of sample interval (m)
SMP_EQP	Sampling equipment code
SPHERE	Sphere (i.e., environment) code from which the sample came
TOT_WGT	Total weight of sample (g)
UNITS	Units associated with PARM, P, and R
WET_WGT	Total wet weight of sample (g)
P_ALP	Nonnumeric result associated with PARM

ALLTISM.DBF	Miscellaneous tissue residue
SOURCE	Identification of data origin (e.g., REG4 is the Region 4 Pilot Study)
AGENCY	Identification of group responsible for collecting data (e.g., NS&T is NOAA's National Status and Trends Program)
STATION	Monitoring station identification code. (ODES NOTE: STATION = <i>STN_CD</i> ' ' <i>STATION</i> DATE. DMATS NOTE: STATION = <i>ID</i> ' ' <i>STATIONI</i> ' ' <i>SERIES</i> ' ' <i>SCAN</i> .)
DATE	Date of sample collection
SAMPLE	Unique sample identifier code
SEQ	Computer-generated sequence number when multiple samples were taken; SOURCE, AGENCY, STATION, and DATE were identical; and no SAMPLE, SUBSAMPL, or REPLICAT codes were provided
REPLICAT	Unique replicate identifier code
ANAT_CD	Organ/tissue sampled code
CAS	CAS number for analyte
CLEANUP	Sample cleanup code to indicate an additional step taken to further purify the sample extracts or digestates
COMPOSIT	A unique identifier to indicate a sample created by compositing tissues from several individuals.
DRY_WGT	Percent of total sample remaining after drying
EXT_MTHO	Extraction method code to indicate the method used to extract or digest the sample matrix and remove or isolate the chemical of concern
INSTRUME	Instrument code to identify the final chemical analysis method(s) used for analyzing the sample
LENGTH	Length of specimen
LIPIDS	Lipids (%)
LIFE_STA	Life stage code to identify the life stage of sample
MEAS_BAS	Result is wet or dry weight basis (see also P)
NUMB_IND	Number of organisms in sample
P	Result associated with PARM

PARM	Analyte measured (see also P and R)
R	Remark code associated with PARM and P
SEX	Sex code used to identify sex of sample
SMP_EQP	Sampling equipment code
SPECCODE	Species code
SPEC_SCI	Species scientific name
SPECIMEN	Unique identifier for the individual organism being analyzed
UNITS	Units associated with PARM, P, and R
WET_WGT	Total weight of sample
P_ALP	Nonnumeric result associated with PARM
<hr/>	
ALLELUT.DBF	Elutriate
SOURCE	Identification of data origin (e.g., REG4 is the Region 4 Pilot Study)
AGENCY	Identification of group responsible for collecting data (e.g., NS&T is NOAA's National Status and Trends Program)
STATION	Monitoring station identification code. (ODES NOTE: STATION = STN_CD ' ' STATION DATE. DMATS NOTE: STATION = ID ' ' STATION ' ' SERIES ' ' SCAN.)
DATE	Date of sample collection
SAMPLE	Unique sample identifier code
SEQ	Computer-generated sequence number when multiple samples were taken; SOURCE, AGENCY, STATION, and DATE were identical; and no SAMPLE, SUBSAMPL, or REPLICAT codes were provided.
SUBSAMPL	Unique subsample identifier code
REPLICAT	Unique replicate identifier code
CAS	CAS number for analyte
EXT_MTHO	Extraction method code to indicate the method used to extract or digest the sample matrix and remove or isolate the chemical of concern
INSTRUME	Instrument code to identify the final chemical analysis method(s) used for analyzing the sample
P	Result associated with PARM ($\mu\text{g/L}$)
PARM	Analyte measured (see also P and R)
R	Remark code associated with PARM and P
SAMP_DTL	Depth to bottom of sample interval (m)
SAMP_DTU	Depth to top of sample interval (m)
SAMP_EQP	Sampling equipment code
<hr/>	
LOADD.DBF	PCS/TRI loadings
ID	Facility identification number
CAS	CAS number for analyte
CHEMICAL	Analyte name
SIC	SIC code for facility
E3KGY0	PCS loadings using below detection limit (dl) equal to 0.0 assumption
E3KGYE	PCS loadings using below detection limit equal to 0.5-dl assumption
E3KGY1	PCS loadings using below detection limit equal to dl assumption
E3FLO0	PCS flow using below detection limit equal to 0.0 assumption
E3FLOE	PCS flow using below detection limit equal to 0.5-dl assumption
E3FLO1	PCS flow using below detection limit equal to dl assumption
E6KGYE	TRI POTW transfers
E6KGY75	75 percent of TRI POTW transfers

LOADS.DBF **PCS/TRI facilities (have loadings data)**

ID	Facility identification number
CODE	"PCS" or "TRI"
SPC	State postal code
LAT	Latitude (decimal degrees)
LNG	Longitude (decimal degrees)
NSIREACH	Reach File 1 Reach

LOADO.DBF **Other PCS/TRI facilities (no associated loadings data)**

ID	Facility identification number
SPC	State postal code
LAT	Latitude (decimal degrees)
LNG	Longitude (decimal degrees)
NSIREACH	Reach File 1 Reach

BIOTCODE.DBF **Toxicity phase for biotoxicity table (ALLBIOT)**

NAME	Genus and species name
PHASE	Toxicity phase listed in source of data (when available)
SOURCE	Identification of data origin (e.g., REG4 is the Region 4 Pilot Study)
NSIPHASE	Toxicity phase used by NSI

ELUTPARM.DBF **List of analytes for elutriate table (ALLELUT)**

SOURCE	Identification of data origin (e.g., REG4 is the Region 4 Pilot Study)
PARM	Analyte measured (see also P and R)
CAS	CAS number for analyte
LNAME	Analyte long name

SED_PARM.DBF **List of analytes for sediment tables (ALLSEDI, ALLSEDM)**

SOURCE	Identification of data origin (e.g., REG4 is the Region 4 Pilot Study)
PARM	Analyte measured (see also P and R)
CAS	CAS number for analyte
LNAME	Analyte long name

TIS_CODE.DBF **List of species for tissue tables (ALLTISS, ALLTISM)**

SPECCODE	Species code
SPEC_SCI	Species scientific name
SPEC_COM	Species common name
RES_MIG	Species resident, migratory, or either
BOT_PEL	Species benthic, pelagic, or either
EDIBLE	Species considered edible by humans

TIS_PARM.DBF **List of analytes for tissue tables (ALLTISS, ALLTISM)**

SOURCE	Identification of data origin (e.g., REG4 is the Region 4 Pilot Study)
PARM	Analyte measured (see also P and R)

CAS CAS number for analyte
LNAME Analyte long name

ALLSUPR.DBF Superfund facilities

STATE State postal code
ID Superfund identification
NAME Facility name
COUNTY County name
CNTY_FIP 3-digit county FIPS code
C0305 C0305
C0326 C0326
LAT Latitude (decimal degrees)
LNG Longitude (decimal degrees)
NSIREACH Reach File 1 Reach

ALLBENA.DBF Benthic species abundance

SOURCE Identification of data origin (e.g., REG4 is the Region 4 Pilot Study)
AGENCY Identification of group responsible for collecting data (e.g., NS&T is NOAA's National Status and Trends Program)
STATION Monitoring station identification code. (ODES NOTE: STATION = STN_CD || ' ' || STATION || DATE. DMATS NOTE: STATION = ID || ' ' || STATIONI || ' ' || SERIES || ' ' || SCAN.)

DATE Date of sample collection
SAMPLE Unique sample identifier code
REPLICAT Unique replicate identifier code
BOTTOM Bottom type
AREA_BAS Area basis for reported data
COMM_BAS Basis for community abundance measurements
EXT_MTHO Extraction method code to indicate the method used to extract or digest the sample matrix and remove or isolate the chemical of concern

GENUS Organism genus
MESH_SZ Seive mesh size
N_REP Number of replicate samples
NUMB_IND Total number of individuals
NUMB_SPE Total number of unique species
ORDER Organism order
P Result associated with PARM
PARM Analyte measured (see also P and R)
P_MEAN Mean P
P_STD Standard deviation of P
R Remark code associated with P and PARM
SAMP_DTL Depth to bottom of sample interval (m)
SAMP_DTU Depth to top of sample interval (m)
SPECIES Organism species
SPECCODE Species code
UNITS Units associated with PARM, P, and R

ALLBENC.DBF Benthic community

SOURCE Identification of data origin (e.g., REG4 is the Region 4 Pilot Study)

AGENCY	Identification of group responsible for collecting data (e.g., NS&T is NOAA's National Status and Trends Program)
STATION	Monitoring station identification code. (ODES NOTE: STATION = <i>STN_CD</i> ' ' <i>STATION</i> DATE. DMATS NOTE: STATION = <i>ID</i> ' ' <i>STATION</i> ' ' <i>SERIES</i> ' ' <i>SCAN</i> .)
DATE	Date of sample collection
SAMPLE	Unique sample identifier code
AMPHIPOD	Number of amphipod
AMPHMABN	Mean abundance of amphipods
AREA_BAS	Area basis for reported data
ARTHROPO	Number of arthropods in the sample
BIOM_TOT	Total biomass (g)
BIOMMEAN	Mean biomass per grab (g)
BIV_MABN	Mean abundance of bivalves (g)
BSPINDEX	Benthic species index
BSP_GRAB	Number of grabs
BSP_MABN	Mean abundance per grab
BSP_MDIV	Mean Shannon-Wiener diversity index
BSP_MEAN	Mean number of species per grab
BSP_MEXP	Expected mean number of species
BSP_TABN	Total abundance
BSP_TDIV	Pooled Shannon-Wiener diversity index
BSP_TOT	Total number of species
CAPIMABN	Mean abundance of capitellids
COMM_BAS	Basis for community abundance measurements
CRUSTACE	Number of crustaceans in the sample
DECAMABN	Mean abundance of decapods
DOMINANC	Numeric dominance in the sample
ECHINODE	Number of echinoderms in the sample
EVENESS	Evenness
ITI	ITI
MED_DIAM	50% quartile diameter (phi)
MISC_TAX	Number of miscellaneous taxa in sample
MOIST_M	Sediment moisture content (%)
MOLLUSCS	Number of molluscs in the sample
NEMATODE	Number of nematodes in the sample
OLIGOCHA	Number of oligochaetes in the sample
PABN_AMP	Percent abundance amphipods
PABN_BIV	Percent abundance bivalves
PABN_GAS	Percent abundance gastropods
PABN_TUB	Percent abundance tubificids
PLYC_MWT	Mean biomass per polychaete (g)
PLYCMABN	Mean abundance of polychaetes
P_SENSIT	Abundance of pollution sensitive organisms (%)
P_TOLERA	Abundance of pollution tolerant organisms (%)
POLYCHAE	Number of polychaetes in the sample
QUARDVTM	Phi quartile deviation
Q1_PHI	25% quartile diameter (phi)
Q3_PHI	75% quartile diameter (phi)
RPDDEP_M	Mean RPD in mm
SICL_B_M	Mean silt/clay content (%)
SKEWNESS	Phi quartile skewness
TUBIMABN	Mean abundance of tubificids

ALLHIST.DBF	Histopathology
SOURCE	Identification of data origin (e.g., REG4 is the Region 4 Pilot Study)
AGENCY	Identification of group responsible for collecting data (e.g., NS&T is NOAA's National Status and Trends Program)
STATION	Monitoring station identification code. (ODES NOTE: STATION = STN_CD ' ' STATION DATE. DMATS NOTE: STATION = ID ' ' STATION ' ' SERIES ' ' SCAN.)
DATE	Date of sample collection
BODYPATH	Number of fish with body pathologies
BRNCPATH	Number of fish with branchial pathologies
BUCCPATH	Number of fish with buccal pathologies
FSP_ABN	Abundance (number/rawl)
FSP_TOT	Number of species
MNMDTRSH	Manmade trash (Y/N)

ALLFISA.DBF	Fish abundance
SOURCE	Identification of data origin (e.g., REG4 is the Region 4 Pilot Study)
AGENCY	Identification of group responsible for collecting data (e.g., NS&T is NOAA's National Status and Trends Program)
STATION	Monitoring station identification code. (ODES NOTE: STATION = STN_CD ' ' STATION DATE. DMATS NOTE: STATION = ID ' ' STATION ' ' SERIES ' ' SCAN.)
DATE	Date of sample collection
LEN_MEAN	Mean length (in)
LEN_STD	Standard deviation length (in)
P	Result associated with PARM
PARM	Analyte measured (see also P)
SPECCODE	Species code
UNITS	Units associated with PARM and P

SPEC-CD.DBF	Species codes for benthic data
SPECCODE	Species code
SPEC_SCI	Species scientific name
SPEC_COM	Species common name

FISH-CD.DBF	Species codes for fish abundance data
SPECCODE	Species code
SPEC_SCI	Species scientific name
SPEC_COM	Species common name

Appendix B

Description of Evaluation Parameters Used in the NSI Data Evaluation

Chapter 2 of this document presented the methodology used in the evaluation of the NSI data. This appendix describes in greater detail the screening values and other parameters used in the NSI data evaluation. The actual parameter values used are presented in Appendix D. For the purpose of discussion, the sediment evaluation parameters have been placed into three groups: (1) those used to assess potential impacts on aquatic life, (2) those used to assess potential impacts on human health, and (3) those used to assess potential impacts on wildlife. The uncertainties associated with the use of these parameters in the NSI data evaluation are discussed in Chapter 5.

Aquatic Life Assessments

To evaluate the potential threat to aquatic life from chemical contaminants detected in sediments, measured concentrations of contaminants were compared to sediment chemistry screening levels. The results of toxicity tests to indicate the actual toxicity of sediment samples to species of aquatic organisms, when available, were also evaluated for the NSI.

Sediment chemistry screening levels are reference values above which sediment contaminant concentrations could pose a significant threat to aquatic life. Several different approaches, based on causal or empirical correlative methodologies, have been developed for deriving screening levels of sediment contaminants. Each of these approaches attempts to predict contaminant concentration levels that could result in adverse effects to benthic species, which are extrapolated to represent the entire aquatic community for this evaluation. For the purpose of this analysis, the screening levels selected include the following:

- EPA's draft sediment quality criteria (SQCs) for five nonionic organic chemicals, developed using an equilibrium partitioning approach (USEPA, 1992a, 1993a).
- Sediment quality advisory levels (SQALs) for selected nonionic organic chemicals, developed using an equilibrium partitioning approach (USEPA, 1992a, 1993a).
- The sum of simultaneously extracted divalent transition metals concentrations minus the acid-volatile sulfide concentration ($[SEM] - [AVS]$), also based on an equilibrium partitioning approach.
- Effects range-median (ERM) and effects range-low (ERL) values for selected nonionic organics and metals developed by Long et al. (1995).
- Probable effects levels (PELs) and threshold effects levels (TELs) for selected nonionic organics and metals developed for the Florida Department of Environmental Protection (FDEP, 1994).
- Apparent effects thresholds (AETs) for selected organics and metals developed by Barrick et al. (1988).

The principles behind the development of each of these sediment chemistry screening values are discussed below. The sediment toxicity tests are also briefly described in this section.

Equilibrium Partitioning Approaches

The potential toxicity of sediment-associated nonionic organic chemicals and divalent metals is indicated by the amount of the contaminant that is uncomplexed or freely available in the interstitial (pore) water. The bioavailability and toxicity of nonionic organic chemicals and divalent metals in sediments are mediated by several physical, chemical, and biological factors, including sediment grain size, particulate and dissolved organic carbon, and sulfide produced by sulfate-reducing bacteria (Di Toro et al., 1991, 1992; Howard and Evans, 1993). For nonionic organic chemicals, sorption to the organic carbon dissolved in the interstitial water and bound to sediment particles is the most important factor affecting bioavailability. Sulfide, specifically the reactive solid-phase sulfide fraction that can be extracted by cold hydrochloric acid (acid-volatile sulfide, or AVS), appears to control the bioavailability of most divalent metal ions because of the sulfide ions' high affinity for divalent metals, resulting in the formation of insoluble metal sulfides in anaerobic sediments.

When the concentrations of nonionic organic chemicals and divalent metals were measured in pore water extracted from spiked sediment and field-collected sediment used in toxicity tests, the biological effects observed in those tests occurred at similar pore water concentrations, even when different types of sediments were used, typically within a factor of 2 (Di Toro et al., 1991, 1992). Biological effects also occurred at similar concentrations in tests with different sediment types containing different amounts of organic carbon (OC) when (1) the dry-weight sediment concentrations of nonionic organic chemicals were normalized for organic carbon content (i.e., $\mu\text{g chemical/g}_{\text{OC}}$) and (2) when the difference between molar concentrations of simultaneously extracted metals ([SEM]) in the sediment exceeded the molar concentration of AVS ([AVS]) in the sediments by similar amounts (the mortality of sensitive species increases in the range of 1.5 to 12.5 μmol of SEM per μmol of AVS). Most importantly, the effects concentrations in the sediment could be predicted from the effects concentrations determined in water-only exposures to these chemicals. Most measurements of sediment chemical concentrations are made from whole sediment samples and converted to units of chemical per dry-weight of sediment, because of the difficulties in extracting the pore water. However, when dry-weight concentrations of nonionic organics and metals were used to plot concentration-response curves of the toxicity of different sediments, biological effects occurred at different dry-weight concentrations when measured in different sediments (Luoma, 1983; USEPA, 1993a). To develop criteria or advisory levels for comparing the toxicity of different chemicals in different sediments, it was necessary to examine the role of organic carbon and other complexing factors in the bioavailability of chemicals in sediment.

In sediment, the partitioning of a nonionic organic chemical between organic carbon and pore water and the partitioning of a divalent metal between the solid and solution phases are assumed to be at equilibrium. The fugacity (activity) of the chemical in each of these phases is the same at equilibrium. Fugacity describes mathematically the rates at which chemicals diffuse or are transported between phases (Mackay, 1991). Hence, an organism in the sediment is assumed to receive an equivalent exposure from water only or from any equilibrated phase. The pathway of exposure might include pore water (respiration), sediment carbon (ingestion), sediment organism (ingestion), or a mixture of routes. The biological effect is produced by the chemical activity of the single phase or the equilibrated system (Di Toro et al., 1991). The equilibrium partitioning approach uses this partitioning theory to relate the dry-weight sediment concentration of a particular chemical that causes an adverse biological effect to the equivalent free chemical concentration in pore water and to the concentration sorbed to sediment organic carbon or bound to sulfide. The theoretical causal resolution of chemical bioavailability in relation to chemical toxicity in different sediments differentiates equilibrium partitioning approaches from purely empirical correlative assessment methods (described later in this section).

The processes that govern the partitioning of chemical contaminants among sediments, pore water, and biota are better understood for some kinds of chemicals than for others. Partitioning of nonionic hydrophobic organic compounds between sediments and pore water is highly correlated with the organic carbon content of sediments, but it does not account for all of the toxicity variation observed between sediment and water-only experimental exposures. Other factors that can affect biological responses are not considered in the model. The equilibrium partitioning approach has been tested using only nonionic organic chemicals with octanol/water partition coefficients ($\log K_{\text{ow}}$ s) between 3.8 and 5.3. However, because the theory should be applicable to nonionic organic chemicals with $\log K_{\text{ow}}$ s from 2.0 to 5.5 (Dave Hansen, EPA/ORD-Narragansett, pers. commun., April 17, 1995), nonionic organic chemicals with $\log K_{\text{ow}}$ s in this range were evaluated for the analysis of NSI data. For trace metals, concentrations of sulfides and organic carbon have been identified as important factors that control the phase associations and, therefore, the bioavailability of trace metals in

anoxic sediments. However, models that can use these factors to predict the bioavailability of trace metals in sediments are not fully developed (see below). Mechanisms that control the partitioning of nonionic and nonpolar organic compounds with $\log K_{ow}$ s of less than 2.0 or greater than 5.5 and polar organic compounds in sediments, and affect their toxicity to benthic organisms, are less well understood. Models for predicting biological effects from concentrations of such compounds have not yet been developed; therefore, these chemicals have not been evaluated using equilibrium partitioning approaches.

Draft Sediment Quality Criteria

The equilibrium partitioning model was selected for the development of sediment quality criteria because it can be applied to predict sediment contaminant concentrations below which biological effects are not expected to occur based on the toxicity of individual nonionic organic chemicals—and hence can protect benthic aquatic life in bedded, permanently inundated, or intertidal sediments—while accounting for sediment characteristics that affect the bioavailability of the chemical (Di Toro et al., 1991; USEPA, 1993a). The predominant phase for sorption of nonionic organic chemicals to sediment particles appears to be organic carbon, for sediments in which the fraction of organic carbon (f_{oc}) is greater than 0.2 percent.

The partitioning of a chemical between the interstitial water and sediment organic carbon is explained by the sediment/pore water partition coefficient for a chemical, K_p , which is equal to the organic carbon content of the sediment (f_{oc}) multiplied by the sediment particle organic carbon partition coefficient (K_{oc}). K_p is the ratio of the concentration of the chemical in the sediment to the concentration of the chemical in the pore water. Normalizing the dry-weight concentration of the chemical in sediment to organic carbon is as appropriate as using the interstitial water concentration of the chemical because organic carbon in the sediment can also bind the chemical and affect its bioavailability and toxicity. The particle organic carbon partition coefficient (K_{oc}) is related to the chemical's octanol/water partition coefficient (K_{ow}) by the following equation (Di Toro et al., 1991):

$$\log K_{oc} = 0.00028 + 0.983(\log K_{ow})$$

The octanol/water partition coefficient for each chemical can thus predict the likelihood of the chemical to complex or sorb to organic carbon, when measured with modern experimental techniques that provide the most accurate estimate of this parameter. The concentration of the chemical on sediment particles (C_s) is then equal to the dissolved concentration of chemical (C_d) multiplied by the organic carbon content of the sediment (f_{oc}) and the particle organic carbon partition coefficient (K_{oc}), when f_{oc} is greater than 0.2 percent (USEPA, 1993a), thus normalizing the dry-weight sediment concentration of the chemical to the organic carbon content of the sediment.

$$C_s = C_d f_{oc} K_{oc}$$

The criterion for the dissolved concentration of chemical (C_d) is derived from the final chronic value (FCV) of EPA's water quality criteria (USEPA, 1985). Freshwater and saltwater FCVs are based on the results of acceptable laboratory tests conducted to determine the toxicity of a chemical in water to a variety of species of aquatic organisms, and they represent the highest levels of a chemical to which organisms can be exposed without producing toxic effects. This level is predicted to protect approximately 95 percent of aquatic life under certain conditions. An evaluation of data from the water quality criteria documents and benthic colonization experiments demonstrated that benthic species have chemical sensitivities similar to those of water column species (Di Toro et al., 1991). Thus, if the concentration of a chemical in sediment, measured with respect to the sediment organic carbon content, does not exceed the sediment quality criterion, then no adverse biological effects from that chemical would be expected (USEPA, 1992a, 1993a).

EPA has developed and published draft freshwater sediment quality criteria (SQC) for the protection of aquatic life for five contaminants: acenaphthene, dieldrin, endrin, fluoranthene, and phenanthrene. These draft SQCs are based on the equilibrium partitioning approach (USEPA 1993b, c, d, e, f) using the aquatic life water quality criterion final chronic value (FCV, in $\mu\text{g/L}$) and the partition coefficient between sediment and pore water (K_p , in L/g sediment) for the chemical

chemical of interest (Di Toro et al., 1991; USEPA, 1993a). Thus, $SQC = K_p FCV$. On a sediment organic carbon basis, the sediment quality criterion, SQC_{oc} , is:

$$SQC_{oc}(\mu g / g_{oc}) = FCV(\mu g / L) \chi K_{oc}(L / kg) \chi (10^{-3} kg_{oc} / g_{oc})$$

where:

FCV = EPA aquatic life water quality criterion final chronic value and
 K_{oc} = organic carbon-water partitioning coefficient.

K_{oc} is presumed to be independent of sediment type for nonionic organic chemicals, so that the SQC_{oc} is also independent of sediment type. Using a site-specific organic carbon fraction, f_{oc} (g_{oc}/g sediment), the SQC_{oc} can be expressed as a sediment-specific value, the SQC:

$$SQC = (SQC_{oc})(f_{oc})$$

Sediment Quality Advisory Levels

EPA intends to develop sediment quality criteria for additional chemicals in the future. In the interim, EPA's Office of Science and Technology developed equilibrium partitioning-based sediment quality advisory levels (SQALs) using the following equation:

$$SQAL_{oc}(\mu g / g_{oc}) = [FCV, SCV(\mu g / L)] \chi K_{oc}(L / kg) \chi (10^{-3} kg_{oc} / g_{oc})$$

where:

$SQAL_{oc}$ = calculated sediment quality advisory level;
 FCV, SCV = EPA aquatic life chronic criterion (final chronic value, FCV), or other chronic threshold water concentration (secondary chronic value, SCV); and
 K_{oc} = organic carbon-water partitioning coefficient.

As noted in Chapter 2, EPA has proposed sediment quality criteria (SQC) for five chemicals based on the highest quality toxicity and octanol/water partitioning (K_{ow}) data, which have been reviewed extensively. This section describes the sources of data used to calculate the values used in the SQAL equations: $\log K_{ow}$ s (used to derive K_{oc} s) and chronic threshold water concentrations. A detailed description of the methods and data used to develop SQALs for specific chemicals using the equilibrium partitioning approach will be published by EPA as a separate document.

SQALs for use in the NSI data evaluation were developed in conjunction with other programs at EPA (established under the Resource Conservation and Recovery Act, RCRA, and the Superfund Amendments and Authorization Act, SARA) to provide the same values for conducting screening-level evaluations of sediment toxicity for these programs. The SQALs (as well as the other sediment chemistry threshold levels) are meant to be used for *screening purposes only*. The screening values are not regulatory criteria, site-specific cleanup standards, or remediation goals. The screening levels are set to be appropriately conservative, so samples that do not exceed the screen would not be expected to exhibit adverse effects from the action of the specific chemical evaluated; exceeding the screening levels does not indicate the level or type of risk at a particular site, but can be used to target additional investigations. EPA's Office of Research and Development (ORD), including staff from Environmental Research Laboratory, Athens, Georgia; Environmental Research Laboratory, Duluth, Minnesota; and Environmental Research Laboratory, Narragansett, Rhode Island, provided guidance and assisted in the development of the necessary values. The SQALs used for the NSI data evaluation are presented with other screening values in Table D-1 of Appendix D.

Method for Determination of $\log K_{ow}$ s. $\log K_{ow}$ values were initially identified in summary texts on physical-chemical properties, such as Howard (1990) and Mackay et al. (1992a, b) and accompanying volumes. Additional compendia of $\log K_{ow}$ values were also evaluated, including De Kock and Lord (1987), Doucette and Andren (1988), Klein et al. (1988), De Bruijn et al. (1989), Isnard and Lambert (1989), Leo (1993), Noble (1993), and Stephan (1993). To supplement these sources, on-line database searches were conducted in ChemFate, TOXLINE, and Hazardous Substances Data Bank (HSDB) (National Library of Medicine); Internet databases such as CARL UNCOVER; and

EPA databases such as ASTER, OLS, and the ORD BBS. Original references were identified for the values, and additional values were identified. In cases where log K_{ow} values varied over several orders of magnitude or measured values could not be identified, detailed on-line searches were conducted using TOXLIT, Chemical Abstracts, and DIALOG. Values identified from all of these sources and the method used to obtain each log K_{ow} value were compiled for each chemical. A few chemicals lacked experimentally measured log K_{ow} s, and no log K_{ow} data were available from any source for butachlor, DCPA/Dacthal, and Ethion/Bladen.

The determination of K_{ow} values was based on experimental measurements taken primarily by the slow-stir, generator-column, and shake-flask methodologies. The SPARC Properties Calculator model was also used to generate K_{ow} values, when appropriate, for comparison with the measured values. Values that appeared to be considerably different from the rest were considered to be outliers and were not used in the calculation.

For each chemical, the available value based on one of these methods was given preference. If more than one such value was available, the log K_{ow} value was calculated as the arithmetic mean of those values (USEPA, 1994). Recommended log K_{ow} s were finalized by ORD-Athens based on recommended criteria, and the justification for selection of each value was included in the report (Karickhoff and Long, April 10, 1995, report).

Selection of Chronic Toxicity Values. A hierarchy of sources for chronic toxicity values to develop the SQALs was prepared. The following sources were identified and ranked from most to least confidence in the chronic values to be used:

1. Sediment quality criteria (SQC).
2. Final chronic values from the Great Lakes Initiative (USEPA, 1995c).
3. Final chronic values from the National Ambient Water Quality Criteria documents.
4. Final chronic values from freshwater criteria documents.
5. Final chronic values developed from data in EPA's Aquatic Toxicity Information Retrieval database (AQUIRE) and other sources.
- 6a. Secondary chronic values developed from data in AQUIRE and other sources.
- 6b. Secondary chronic values from Suter and Mabrey (1994)

EPA SQCs were available for five chemicals: acenaphthene, dieldrin, endrin, fluoranthene, and phenanthrene. There were no final chronic values (FCVs) obtained by the aquatic life criteria methodology (referred to as "Tier I") described in USEPA (1995c) available for the remaining chemicals in the NSI. Two SQALs were based on the FCVs from National Ambient Water Quality Criteria documents, for gamma-BHC/Lindane and toxaphene. No FCVs were available from criteria documents.

Thirteen SQALs were based on work conducted by Oak Ridge National Laboratories (Suter and Mabrey, 1994) using the USEPA (1995c) methodology for obtaining secondary chronic values ("Tier II"). This methodology was developed to obtain whole-effluent toxicity screening values based on all available data, but the SCVs could also be calculated with fewer toxicity data than are required for the criteria methodology. The SCVs are generally more conservative than those which can be produced by the FCV methodology, reflecting greater uncertainty in the absence of additional toxicity data. The minimum requirement for deriving an SCV is toxicity data from a single taxonomic family (Daphnidae), provided the data are acceptable. Only those values from Suter and Mabrey (1994) that included at least one daphnid test result in the calculation of the SCV were included for the NSI. SCVs from Suter and Mabrey (1994) were used to develop SQALs for the following chemicals:

benzene	napthalene
chlorobenzene	1,1,2,2-tetrachloroethane
delta-BHC	tetrachloroethene
dibenzofuran	toluene
diethyl phthalate	1,1,1-trichloroethane
di-n-butyl phthalate	trichloroethene
ethylbenzene	

A preliminary search of data records in EPA's AQUIRE database indicated that the following chemicals might have sufficient toxicity data for the development of SCVs:

biphenyl	fluorene
4-bromophenyl phenyl ether	hexachlorethane
butyl benzyl phthalate	malathion
diazinon	methoxychlor
1,2-dichlorobenzene	pentachlorobenzene
1,3-dichlorobenzene	tetrachloromethane
1,4-dichlorobenzene	tribromomethane
endosulfan mixed isomers	1,2,4-trichlorobenzene
alpha-endosulfan	trichloromethane
beta-endosulfan	m-xylene

Insufficient toxicity test data were found in AQUIRE for acenaphthylene, endosulfan sulfate, heptachlor epoxide, and trichlorofluoromethane. In addition, review of AQUIRE data records indicated that no daphnid acute toxicity tests had been conducted for hexachlorobutadiene. These chemicals were dropped from further development of SQALs.

Acid-Volatile Sulfide Concentration

The use of the total concentration of a trace metal in sediment as a measure of its toxicity and its ability to bioaccumulate is not supported by field and laboratory studies because different sediments exhibit different degrees of bioavailability for the same total quantity of metal (Di Toro et al., 1990; Luoma, 1983). These differences have been reconciled by relating organism toxic response (mortality) to the metal concentration in the sediment pore water (Adams et al., 1985; Di Toro et al., 1990). Metals form insoluble complexes with the reactive pool of solid-phase sulfides in sediments (iron and manganese sulfides), restricting their bioavailability. The metals that can bind to these sulfides have sulfide solubility parameters smaller than those of iron sulfide and include nickel, zinc, cadmium, lead, copper, and mercury. Acid-volatile sulfide (AVS) is one of the major chemical components that control the activities and availability of metals in the pore waters of anoxic sediments (Meyer et al., 1994).

AVS is operationally defined as the sulfide liberated from a sediment sample to which hydrochloric acid has been added at room temperature under anoxic conditions (Meyer et al., 1994). The metals concentrations that are extracted during the same analysis are termed the simultaneously extracted metals (SEM). SEM is operationally defined as those metals which form less soluble sulfides than do iron or manganese (i.e., the solubility products of these sulfides are lower than that of iron or manganese sulfide) and that are at least partially soluble under the same test conditions in which the AVS content of the sediment is determined (Allen et al., 1993; Di Toro et al., 1992; Meyer et al., 1994).

Laboratory studies using spiked sediments and field-collected metal-contaminated sediments demonstrated that when the molar ratio of SEM to AVS $[SEM]/[AVS]$ was less than 1 (excess AVS remained), no acute toxicity (mortality greater than 50 percent) was observed in any sediment for any benthic test organism. When $[SEM]/[AVS]$ was greater than 1 (excess metal remained), the mortality of sensitive species (e.g., amphipods) increased in the range of 1.5 to 2.5 μmol of SEM per μmol AVS (Casas and Creclius, 1994; Di Toro et al., 1992).

Experimental studies indicate that the lower limit of applicability for AVS is approximately 1 μmol AVS/g sediment and possibly lower; other sorption phases, such as organic carbon, probably become important for sediments with smaller AVS concentrations and for metals with large partition coefficients and large chronic water quality criteria (Di Toro et al., 1990). In addition, studies indicate that copper, as well as mercury, might be associated with another phase in sediments, such as organic carbon, and AVS alone might not be the appropriate partitioning phase for predicting its toxicity. Pore-water concentrations of metals should also be evaluated (Allen et al., 1993; Ankley et al., 1993; Casas and Creclius, 1994). However, the AVS approach can be used to predict when a sediment contaminated with metals is not acutely toxic (Ankley et al., 1993; Di Toro et al., 1992).

There are several important factors to consider in interpreting the $[SEM]-[AVS]$ difference. First, all toxic SEMs present in amounts that contribute significantly to the $[SEM]$ sum should be measured. However, because mercury presents special problems, it is not included in the current SEM analysis. Second, if the AVS content of sediment is

(Adams et al., 1992; Zhuang et al., 1994). Most benthic macroorganisms, including those used in toxicity tests, survive in sediments that have a thin oxidized surface layer and then an anoxic layer. The anoxic layer can have significant AVS concentrations that would reduce the metal activity to which these organisms are exposed (Di Toro et al., 1992). Third, AVS varies spatially in sediment—vertically with depth and horizontally where patches of an appropriate carbon source occur under low oxygen conditions for the sulfate-reducing bacteria. Lastly, AVS can vary when sediments are oxygenated during physical disturbance and seasonally as changes in the productivity of the aquatic ecosystem alter the oxidation state of sediment and oxidize metal sulfides; therefore, the toxicity of the metals present in the sediment also changes over time (Howard and Evans, 1993).

Selection of an [SEM] - [AVS] difference sufficiently high to place a sediment in the Tier 1 classification requires careful consideration because the relationship between organism response and the [SEM] - [AVS] difference of sediment depends on the amount and kinds of other binding phases present. Using freshwater and saltwater sediment amphipod toxicity data, researchers at EPA's Environmental Research Laboratory in Narragansett, Rhode Island, plotted [SEM] - [AVS] versus the percentage of sediments with a higher [SEM] - [AVS] value that were toxic. For this analysis, the researchers defined toxicity as greater than 24 percent mortality. Analysis of these data reveals that between 80 percent and 90 percent of the sediments were toxic at [SEM] - [AVS] = 5. The running average mortality at this level was between 44 percent and 62 percent (Hansen, 1995). EPA's Office of Science and Technology selected [SEM] - [AVS] = 5 as the demarcation line between the higher (Tier 1) and intermediate (Tier 2) probability categories.

Biological Effects Correlation Approaches

Biological effects correlation approaches are based on the evaluation of paired field and laboratory data to relate incidence of adverse biological effects to the dry-weight sediment concentration of a specific chemical at a particular site. Researchers use these data sets to identify level-of-concern chemical concentrations based on the probability of observing adverse effects. Exceedance of the identified level-of-concern concentrations is associated with a likelihood of adverse organism response, but it does not demonstrate that a particular chemical is solely responsible. Consequently, correlative approaches do not indicate direct cause-and-effect relationships. In fact, a given site typically contains a mixture of chemicals that contribute to observed adverse effects to some degree. These and other potentially mitigating factors tend to make screening values based on correlative approaches lower than screening values based on effects caused by a single chemical. However, correlative procedures differ from one another by design and, subsequently, in how they relate to sediment toxicity. For example, ERMs are levels usually associated with adverse effects, whereas AETs are levels intended to always be associated with adverse effects. Thus, when in error, ERMs minimize false negatives relative to AETs and AETs minimize false positives relative to ERMs (Ingersoll et al., 1996).

Effects Range-Medians and Effects Range-Lows

The effects range approach for deriving sediment quality guidelines involves matching dry-weight sediment contaminant concentrations with associated biological effects data. Long and Morgan (1990) originally developed informal guidelines using this approach for evaluation of NOAA's National Status and Trends (NS&T) data. Data from equilibrium partitioning modeling, laboratory, and field studies conducted throughout North America were used to determine the concentration ranges that are rarely, sometimes, and usually associated with toxicity for marine and estuarine sediments (Long et al., 1995). Effects range-low (ERL) and effects range-median (ERM) values were derived by Long et al. (1995) for 28 chemicals or classes of chemicals: 9 trace metals, total PCBs, 13 individual polynuclear aromatic hydrocarbons (PAHs), 3 classes of PAHs (total low molecular weight, total high molecular weight, and total PAH), and 2 pesticides (p,p'-DDE and total DDT). For each chemical, sediment concentration data with incidence of observed adverse biological effects were identified and ordered. The authors identified the lower 10th-percentile concentration as the ERL and the 50th-percentile concentration as the ERM. In terms of potential biological effects, sediment contaminant concentrations below the ERL are defined as in the "minimal-effects range," values between the ERL and ERM are in the "possible-effects range," and values above the ERM are in the "probable-effects range." Data entered into this biological effects database for sediments (BEDS) were expressed on a dry-weight basis.

The accuracy of these guidelines was evaluated using the data in the database not associated with adverse effects and noting whether the incidence of effects was less than 25 percent in the minimal-effects range, increased consistently with increasing chemical concentrations, and was greater than 75 percent in the probable-effects range. Long et al.

tently with increasing chemical concentrations, and was greater than 75 percent in the probable-effects range. Long et al. (1995) reported that these sediment quality guidelines were most accurate for copper, lead, silver, and all classes of PAHs and most of the individual PAHs; however, accuracy was low for nickel, chromium, mercury, total PCBs, and DDE and DDT. The guidelines generally agreed within factors of 2 to 3 with other guidelines, including the freshwater effects-based criteria from Ontario. The authors attributed variability in the concentrations associated with effects to differences in sensitivities of different taxa and physical factors that affect bioavailability, but they argued that because of the synergistic effects of multiple toxicants, the inclusion of data from many field studies in which mixtures of chemicals were present in sediments could make the guidelines more protective than guidelines based on a single chemical. The authors also emphasized that ERLs and ERMs were intended to be used as informal screening tools only.

Although the ERL and ERM guidelines were not based upon deterministic or cause-effects studies, their accuracy in correctly predicting nontoxicity and toxicity has been determined empirically among field-collected samples (Long et al., in press). Analyses were performed with matching laboratory bioassay data and chemical data from 989 samples collected in regions of the Atlantic, Pacific, and Gulf coasts. Data were gathered from results of amphipod survival tests (*Ampelisca abdita* and *Rhepoxynius abronius*) for all 989 samples. Data from a battery of sensitive bioassays (fertilization success of urchin gametes, embryological development of mollusc embryos, and microbial bioluminescence) were gathered for 358 of these samples. The percentages of samples indicating non-toxicity (not significantly different from controls, $p > 0.05$), significant toxicity ($p < 0.05$), and high toxicity ($p < 0.05$ and mean response > 20 percent difference from controls) were determined for the results of the amphipod tests alone and for the results of any one of the tests performed.

Results of the analyses (summarized in Table B-1) suggest that highly toxic responses occurred in 12 percent of the samples in the amphipod tests and 28 percent of the samples in any one of the tests performed when all chemical concentrations were less than their respective ERL values. These samples were analogous to those classified as Tier 3 in this report (i.e., all chemical concentrations less than the screening values). When one or more chemicals exceeded ERL concentrations, but all concentrations were lower than the ERM concentrations (analogous to Tier 2), the percentages of samples indicating high toxicity were 19 percent in the amphipod tests and 64 percent in any one of the tests performed. The incidence of high toxicity in the amphipod tests increased from 10 percent when only one ERL value was exceeded to 58 percent when 20-24 ERLs were exceeded. The incidence of toxicity in any one of the tests increased from 29 percent when only one ERL was exceeded to 91 percent when 20-24 ERLs were exceeded. In samples analogous to those classified as Tier 1 (one or more ERMs exceeded), the incidence of high toxicity was 42 percent in amphipod tests and 80 percent in any one of the battery of tests performed. If both the significant and highly toxic results were combined in the Tier 1 samples, the percentage of samples indicating toxicity increases to 55 percent in amphipod tests and 87 percent in any one of the tests. As with the ERLs, the incidence of toxicity increased with increasing number of chemicals that exceeded the ERMs.

Probable Effects Levels and Threshold Effects Levels

A method slightly different from that used by Long et al. (1995) to develop ERMs and ERLs was used by the Florida Department of Environmental Protection (FDEP, 1994) to develop similar correlative, effects-based guidelines

Table B-1. Incidence of Toxicity in Amphipod Survival Tests Alone and Any One of 2-4 Tests Performed in Samples Analogous to Those Classified as Tier 1, 2, or 3 (from Long et al., in press)

Chemical Concentrations	Analogous Tier	Amphipod Tests Alone			Any Test Performed		
		% Not Toxic	% Signif. Toxic	% Highly Toxic	% Not Toxic	% Signif. Toxic	% Highly Toxic
all < ERLs	Tier 3	64	23	12	67	5	28
> 1 or more ERLs	Tier 2	59	22	19	20	15	64
> 1 or more ERMs	Tier 1	45	13	42	13	7	80

for Florida's coastal waters. Modifications to the Long et al. (1995) approach increased the relevance of the resultant guidelines to Florida's coastal sediments by making information in the database more consistent and by expanding the information used to derive sediment quality assessment guidelines with additional data from other locations in the United States and Canada, particularly Florida and the southeastern and Gulf of Mexico regions (FDEP, 1994). Three effects ranges were developed with a method that used both the chemical concentrations associated with biological effects (the "effects" data) and those associated with no observed effects (the "no-effects" data). In this method, the threshold effects level (TEL) is the geometric mean of the lower 15th-percentile concentration of the effects data (the ERL) and the 50th-percentile concentration of the no-effects data. The probable-effects level (PEL) is the geometric mean of the 50th-percentile concentration of the effects data (the ERM) and the 85th-percentile concentration of the no-effects data. Essentially, the PEL and TEL reflect the ERM and ERL values adjusted upward or downward depending on the degree of overlap between the distributions of "effects" and "no effects" data. TELs and PELs have been developed for 33 chemicals: 9 trace metals, total PCBs, 13 individual polynuclear aromatic hydrocarbons (PAHs), 3 classes of PAHs (total low molecular weight, total high molecular weight, and total PAH), 6 pesticides (chlordane, dieldrin, p,p' -DDD, p,p' -DDE, p,p' -DDT), and total DDT (FDEP, 1994).

As was the case with the Long et al. (1995) approach, in the FDEP (1994) approach the lower of the two guidelines for each chemical (i.e., the TEL) was assumed to represent the concentration below which toxic effects rarely occurred. In the range of concentrations between the TEL and PEL, effects occasionally occurred. Toxic effects usually or frequently occurred at concentrations above the upper guideline value (i.e., the PEL). TEL and PEL values were developed on a sediment dry-weight basis.

Although the extensive database and evaluation of effects data make this approach applicable to many areas of the country, the available data still have limitations. For example, FDEP (1994) noted that there is a potential for underprotection or overprotection of aquatic resources if the bioavailability of sediment-associated contaminants and other factors affecting toxicity are not included. Most of the TELs and PELs were within a factor of 2 to 3 of other sediment quality guideline values. Most were deemed reliable for evaluating sediment quality in Florida's coastal waters, with less confidence in the values for mercury, nickel, total PCBs, chlordane, lindane, and total DDT. An evaluation of independent sets of field data from Florida, the Gulf of Mexico, California, and New York showed that TELs and PELs correctly predict the toxicity of sediment in 86 percent and 85 percent of the samples, respectively.

As with ERLs and ERMs, the accuracy of TEL and PEL guidelines to correctly predict nontoxicity and toxicity has been determined empirically among field-collected samples (Long et al., in press). Analyses were performed with matching laboratory bioassay data and chemical data from 989 samples collected in regions of the Atlantic, Pacific, and Gulf coasts. Data were gathered from results of amphipod survival tests (*Ampelisca abdita* and *Rhepoxynius abronius*) for all 989 samples. Data from a battery of sensitive bioassays (fertilization success of urchin gametes, embryological development of mollusc embryos, and microbial bioluminescence) were gathered for 358 of these samples. The percentages of samples indicating nontoxicity (not significantly different from controls, $p > 0.05$), significant toxicity ($p < 0.05$), and high toxicity ($p < 0.05$ and mean response >20 percent difference from controls) were determined for the results of the amphipod tests alone and for the results of any one of the tests performed.

Results of the analyses (summarized in Table B-2) suggest that highly toxic responses occurred in 10 percent of the samples in the amphipod tests and 5 percent of the samples in any one of the tests performed when all chemical concentrations were less than their respective TEL values. These samples were analogous to those classified as Tier 3 in this report (i.e., all chemical concentrations less than the screening values). When one or more chemicals exceeded TEL concentrations, but all concentrations were lower than the PEL concentrations (analogous to Tier 2), the percentages of samples indicating high toxicity were 17 percent in the amphipod tests alone and 59 percent in any one of the tests performed. The incidence of high toxicity in the amphipod tests increased from 13 percent when only one TEL value was exceeded to 52 percent when 20-27 TELs were exceeded. The incidence of toxicity in any one of the tests increased from 31 percent when 1-5 TELs were exceeded to 63 percent when 20-27 TELs were exceeded. In samples analogous to those classified as Tier 1 (one or more PELs exceeded), the incidence of high toxicity was 38 percent in amphipod tests and 78 percent in any one of the battery of tests performed. If both the significant and highly toxic results were combined in the Tier 1 samples, the percentage of samples indicating toxicity increases to 51 percent in amphipod tests and 86 percent in any one of the tests. As with the TELs, the incidence of toxicity increased with increasing number of chemicals that exceeded the PELs.

Table B-2. Incidence of Toxicity in Amphipod Survival Tests Alone and Any One of 2-4 Tests Performed in Samples Analogous to Those Classified as Tier 1, 2, or 3 (from Long et al., in press)

Chemical Concentrations	Analogous Tier	Amphipod Tests Alone			Any Test Performed		
		% Not Toxic	% Signif. Toxic	% Highly Toxic	% Not Toxic	% Signif. Toxic	% Highly Toxic
all < TELs	Tier 3	61	29	10	90	5	5
> 1 or more TELs	Tier 2	62	21	17	22	19	59
> 1 or more PELs	Tier 1	49	13	38	14	8	78

Apparent Effects Thresholds

The AET approach is another empirical data evaluation approach to defining concentrations in sediment associated with adverse effects. Barrick et al. (1988) reported that AETs can be developed for any measured chemical (organic or inorganic) with a wide concentration range in the field. The AET concept applies to matched field data for sediment chemistry and any observable biological effects (e.g., bioassay responses, infaunal abundances at various taxonomic levels, bioaccumulation). By using these different biological indicators, application of the resulting sediment quality values enables a wide range of biological effects to be addressed in the management of contaminated sediments. Using sediment samples from Puget Sound in Washington State, AET values have been developed for 52 chemicals: 10 trace metals, 15 individual polynuclear aromatic hydrocarbons (PAHs), 3 pesticides (p,p'-DDD, p,p'-DDE, p,p'-DDT), 6 halogenated organics, and 18 other compounds.

The focus of the AET approach is to identify concentrations of contaminants that are associated exclusively with sediments exhibiting statistically significant biological effects relative to reference sediments. AET values were based on measured chemical concentrations per dry weight of sediment. AETs for each chemical and biological indicator were developed using the following steps (Barrick et al., 1988).

1. Collected "matched" chemical and biological effects data—Conducted chemical and biological effects testing on subsamples of the same field sample.
2. Identified "impacted" and "nonimpacted" stations—Statistically tested the significance of adverse biological effects relative to suitable reference conditions for each sediment sample and biological indicator.
3. Identified the AET using only "nonimpacted" stations—For each chemical, the AET was identified for a given biological indicator as the highest *detected* concentration among sediment samples that did not exhibit statistically significant effects.
4. Verified that statistically significant biological effects were observed at a chemical concentration higher than the AET; otherwise, the AET was only a preliminary minimum estimate.
5. Repeated steps 1-4 for each biological indicator.

For a given data set, the AET value for a chemical is the sediment concentration above which a particular adverse biological effect for individual biological indicators (amphipod bioassay, oyster larvae bioassay, Microtox bioassay, and benthic infaunal abundance) is always significantly different statistically relative to appropriate reference conditions. Two thresholds were recognized in the evaluations conducted in this report, when possible, based on the different indicators. EPA defined the AET-low as the lowest AET among applicable biological indicators, and the AET-high as the highest AET among applicable biological indicators. The use of the high/low AET values is not a recommendation of the authors of the approach; rather it was developed for the NSI evaluation. The two thresholds were used in this evaluation to give a range of effects values (as with the ERL/ERMs and TEL/PELS). AET values based on Microtox bioassays were not used for the NSI evaluation.

Sediment toxicity tests provide important information on the effects of multiple chemical exposures to assist in the evaluation of sediment quality. Methods for testing the acute and chronic toxicity of sediment samples to benthic freshwater and marine organisms have been developed (see reviews in API, 1994; Burton et al., 1992; Lamberson et al., 1992; USEPA, 1994b, c) and used primarily for dredged material evaluation (USEPA and USACOE, 1994). The NSI data contain acute sediment toxicity results from tests in which organisms were exposed to field-collected sediments and mortality was recorded. Results of whole sediment and elutriate toxicity tests were used in the evaluation of the NSI.

Variations in observed toxicity from tests of the same sediment sample may be attributed to the relative sensitivities of the species used in the tests; disruption of geochemistry and kinetic activity of bedded sediment contaminants during sampling, handling, and bioturbation; and laboratory-related confounding factors (Lamberson et al., 1992). Recent studies indicate that aqueous representations of whole sediment (e.g., elutriate) do not accurately predict the bioavailability of some contaminants compared to whole-sediment exposures (Harkey et al., 1994). Acute sediment toxicity tests have been widely accepted by the scientific and regulatory communities and the results can be readily interpreted, although more work is needed on chronic testing (Thomas et al., 1992). Appendix G presents the methodology for evaluating sediment toxicity tests as applied in the NSI data evaluation.

Human Health Assessments

In the evaluation of NSI data, two primary evaluation parameters were used to assess potential human health impacts from sediment contamination: (1) sediment chemistry theoretical bioaccumulation potential and (2) tissue levels of contaminants in demersal, nonmigratory species.

Theoretical Bioaccumulation Potential

The theoretical bioaccumulation potential (TBP) is an estimate of the equilibrium concentration of a contaminant in tissues if the sediment in question were the only source of contamination to the organism (USEPA and USACOE, 1994). The TBP calculation is used as a screening mechanism to represent the magnitude of bioaccumulation likely to be associated with nonpolar organic contaminants in the sediment. At present, the TBP calculation can be performed only for nonpolar organic chemicals; however, methods for TBP calculations for metals and polar organic chemicals are under development (USEPA and USACOE, 1994).

The environmental distribution of nonpolar organic chemicals is controlled largely by their solubility in various media. Therefore, in sediments they tend to occur primarily in association with organic matter (Karickhoff, 1981) and in organisms they are found primarily in the body fats or lipids (Bierman, 1990; Geyer et al., 1982; Konemann and van Leeuwen, 1980; Mackay, 1982). Bioaccumulation of nonpolar organic compounds from sediment can be estimated from the organic carbon content of the sediment, the lipid content of the organism, and the relative affinities of the chemical for sediment organic carbon and animal lipid content (USEPA and USACOE, 1994). It is possible to relate the concentration of a chemical in one phase of a two-phase system to the concentration in the second phase when the system is in equilibrium. The TBP calculation focuses on the equilibrium distribution of a chemical between the sediment and the organism. By normalizing nonpolar organic chemical concentration data for lipid in organisms, and for organic carbon in sediment, it is possible to estimate the preference of a chemical for one phase or the other (USEPA and USACOE, 1994).

The TBP can be calculated relative to the biota-sediment accumulation factor (BSAF), as in the following equation (USEPA and USACOE, 1994):

$$TBP = BSAF(C_s / f_{oc})f_l$$

where TBP is expressed on a whole-body basis in the same units of concentration as C_s and

- TBP = theoretical bioaccumulation potential (ppm);
 C_s = concentration of nonpolar organic chemical in sediment (ppm);

- C_s = concentration of nonpolar organic chemical in sediment (ppm);
 BSAF = biota-sediment accumulation factor (ratio of the concentration of a chemical in tissue, normalized to lipid, to the concentration of the chemical in surface sediment, normalized to organic carbon (in kg sediment organic carbon/kg lipid));
 f_{oc} = total organic carbon (TOC) content of sediment expressed as a decimal fraction (i.e., 1 percent = 0.01); and
 f_l = organism lipid content expressed as a decimal fraction (e. g., 3 percent = 0.03) of fillet or whole-body dry weight.

BSAF values used in the TBP evaluation are discussed in Appendix C. If TOC measurements were not available at a site, f_{oc} was assumed to be 0.01 (1 percent).

For the evaluation of NSI data, EPA selected a 3 percent lipid content in fish fillets for the TBP calculation for assessing human health effects from the consumption of contaminated fish. Lipid normalization is now part of the EPA guidance on bioaccumulation, and the current national methodology uses a 3 percent value for human health assessments. The *Great Lakes Water Quality Initiative Technical Support Document for the Procedure to Determine Bioaccumulation Factors* (USEPA, 1995b) uses a 3.10 percent lipid value for trophic level 4 fish and 1.82 percent for trophic level 3 fish in its human health assessments.

As part of the NSI TBP evaluation, EPA also evaluated percent lipid measurements included in the STORET database, the *National Study of Chemical Residues in Fish* (NSCRF; USEPA, 1992b), and other published sources, and compared those values to the value selected for the NSI evaluation (Appendix C). The mean fillet percent lipid content for various groups of fish species in the STORET database ranged from 0.753 to 4.49 percent; in the NSCRF, mean fillet values ranged from 1.6 to 4.9 percent. The mean whole-body percent lipid content for various groups of fish species in the STORET database ranged from 3.757 to 6.33 percent; in the NSCRF, mean whole-body values ranged from 4.6 to 8.8 percent.

In the NSI data evaluation approach, TBP values were compared to U.S. Food and Drug Administration tolerance/action/guidance levels and EPA risk levels. These parameters are discussed below.

FDA Tolerance/Action/Guidance Levels

The U.S. Food and Drug Administration (FDA) is responsible for the safety of the Nation's commercial food supply, including fish and shellfish, for human consumption. Under the authority of the Federal Food, Drug and Cosmetic Act (FFDCA), FDA ensures that regulated products are safe for use by consumers. The FFDCA authorizes FDA to conduct assessments of the safety of ingredients in foods. The key element of the FFDCA, and the source of FDA's main tools for enforcement, is the prohibition of the "adulteration" of foods. FDA can prescribe the level of contaminant that will render a food adulterated and, therefore, can initiate enforcement action based on scientific data. The establishment of guidance and action levels (informal judgments about the level of a food contaminant to which consumers can be safely exposed) or tolerances (regulations having the force of law) is the regulatory procedure employed by FDA to control environmental contaminants in the commercial food supply.

During the 1970s, the available detection limits were considered to demonstrate elevated contamination and were used as action levels. Since that time, FDA has focused on using risk-based standards. These standards have been derived by individually considering each chemical and the species of fish it is likely to contaminate. FDA also considered (1) the amount of potentially contaminated fish eaten and (2) the average concentrations of contaminants consumed. FDA has established action levels in fish for 10 pesticides and methylmercury, tolerance levels for polychlorinated biphenyls (PCBs), and guidance for 5 metals.

EPA Risk Levels

Potential impacts on humans are evaluated by estimating potential carcinogenic risks and noncarcinogenic hazards associated with the consumption of chemically contaminated fish tissue. In this assessment it was assumed that the only source of contamination to fish is contaminated sediment. The procedures for estimating human health risks due to the consumption of chemically contaminated fish tissue are based on *Risk Assessment Guidance for Superfund*

(USEPA, 1989) and *Guidance for Assessing Chemical Contamination Data for Use in Fish Advisories, Volume II: Development of Risk-Based Intake Limits* (USEPA, 1994a).

EPA human health risk assessment methods were used in this assessment to determine the levels of contamination in fish that might result in a 10^{-5} cancer risk (1 in 100,000 extra chance of cancer over a lifetime) or a noncancer hazard in humans. A 10^{-5} risk level exceeds the lower bound (i.e., 10^{-6}) but is lower than the upper bound (i.e., 10^{-4}) of the risk range accepted by EPA (USEPA, 1990).

Human health cancer risks and noncancer hazards are based on the calculation of the chronic daily intake (CDI) of contaminants of concern:

$$CDI = \frac{(EPC)(IR)(EF)(ED)}{(BW)(AT)}$$

where:

CDI	=	chronic daily intake (mg/kg/day);
EPC	=	exposure point concentration (contaminant concentration in fish);
IR	=	ingestion rate (6.5 g/day);
EF	=	exposure frequency (365 days/year);
ED	=	exposure duration (70 years);
BW	=	body weight (70 kg); and
AT	=	averaging time (70 years x 365 days/year).

These are the same parameter values used by EPA to develop human health water quality criteria. Carcinogenic risks are then quantified using the equation below:

$$\text{Cancer risk}_i = CDI_i \times SF_i$$

where:

Cancer risk _i	=	the potential carcinogenic risk associated with exposure to chemical <i>i</i> (unitless);
CDI _i	=	chronic daily intake for chemical <i>i</i> (mg/kg/day); and
SF _i	=	slope factor for chemical <i>i</i> (mg/kg/day) ⁻¹ .

The hazard quotient, which is used to quantify the potential for an adverse noncarcinogenic effect to occur, is calculated using the following equation:

$$HQ_i = \frac{CDI_i}{RfD_i}$$

where:

HQ _i	=	hazard quotient for chemical <i>i</i> (unitless);
CDI _i	=	chronic daily intake for chemical <i>i</i> (mg/kg/day); and
RfD _i	=	reference dose for chemical <i>i</i> (mg/kg/day).

If the hazard quotient exceeds unity (i.e., 1), an adverse health effect might occur. The higher the hazard quotient, the more likely that an adverse noncarcinogenic effect will occur as a result of exposure to the chemical. If the estimated hazard quotient is less than unity, noncarcinogenic effects are unlikely to occur.

Using these formulas, the fish tissue concentration (EPC) of a contaminant that equates to a cancer risk of 10^{-5} or a hazard quotient that exceeds unity can be back-calculated.

Cancer risk:

$$EPC = \frac{(10^{-5})(BW)(AT)(C_1)}{(IR)(EF)(ED)(SF_1)}$$

Noncancer hazard:

$$EPC = \frac{(BW)(AT)(RfD_1)(C_1)}{(IR)(EF)(ED)}$$

where:

C_1 = conversion factor (10^3 g/kg).

Tissue Levels of Contaminants

In addition to sediment chemistry TBP values, measured levels of contaminants in the tissues of resident aquatic species were used to assess potential human health risk. As was the case with the evaluation of TBP values, the NSI evaluation approach compared contaminant tissue levels to FDA tolerance/action/guidance levels and EPA risk levels. Each of these parameters was discussed in the previous section. In such a comparison it is assumed that contaminant concentrations in tissue result from bioaccumulation of contaminants in the sediment.

Wildlife Assessments

In addition to the evaluation parameters described above for the assessment of potential aquatic life and human health impacts, EPA also conducted a separate analysis of potential wildlife impacts resulting from exposure to sediment contaminants.

Wildlife criteria based on fish tissue concentrations were derived using methods similar to those employed for deriving EPA wildlife criteria, as presented in the *Great Lakes Water Quality Initiative Criteria Documents for the Protection of Wildlife* (USEPA, 1995a). EPA has developed Great Lakes Water Quality Wildlife Criteria for four chemicals: DDT, mercury, 2,3,7,8-TCDD, and PCBs. A Great Lakes Water Quality Wildlife Criterion (GLWC) is the concentration in the water of a substance that, if not exceeded, protects avian and mammalian wildlife populations from adverse effects resulting from the ingestion of surface waters and aquatic prey (USEPA, 1995a). Wildlife values are calculated using the equation:

$$WV = \frac{(NOAEL \times SSF) \times Wt_A}{W_A + (F_A \times BAF)}$$

where:

- WV = wildlife value (mg/L);
- NOAEL = no-observed-adverse-effect level, as derived from mammalian or avian studies (mg/kg-d);
- Wt_A = average weight for the representative species identified for protection (kg);
- W_A = average daily volume of water consumed by the representative species identified for protection (L/d);
- SSF = species sensitivity factor, an extrapolation factor to account for the difference in toxicity between species;
- F_A = average daily amount of food consumed by the representative species identified for protection (kg/d); and
- BAF = bioaccumulation factor (L/kg), the ratio of the concentration of a chemical in tissue, normalized to lipid, to the concentration in ambient water. Chosen using guidelines for wildlife presented in appendix B to part 132, Methodology for Development of Bioaccumulation Factors (*Federal Register*, Vol. 58, No. 72, April 16, 1993).

In the development of the four GLWCs, wildlife values for five representative Great Lakes basin wildlife species (bald eagle, herring gull, belted kingfisher, mink, and river otter) were calculated, and the geometric mean of these values within each taxonomic class (birds and mammals) was determined. The GLWC is the lower of two class-species means (USEPA, 1995a).

The wildlife values are considered to be generally protective of wildlife species. However, it should be noted that the approach is not based on the most sensitive wildlife species, but rather a typical class of either avian or mammalian piscivores. Despite this limitation, this approach is still considered appropriate and conservative because of the many conservative assumptions used to derive these wildlife values (e.g., species sensitivity factors, assumption that animals consume only contaminated fish).

Proposed EPA wildlife criteria are based on surface water contaminant levels protective of potential wildlife exposure. Thus, the proposed EPA wildlife criteria cannot be compared directly to the NSI fish tissue concentrations (either the calculated TBPs or fish tissue monitoring data). Therefore, it was necessary to develop an approach for estimating wildlife criteria for fish tissue based on the same toxicity and exposure parameter assumptions that were used to derive the surface water wildlife criteria: First, wildlife values (i.e., fish tissue concentrations protective of wildlife) were derived for the most sensitive mammalian species (i.e., otter and mink) and avian species (i.e., kingfisher, herring gull, and eagle)—the same species used to derive the proposed EPA wildlife criteria. The equation used to estimate wildlife values for fish tissue is presented below. (Exposure assumptions used for each species are presented in USEPA, 1995a.)

$$WV_{\text{fish}} = \frac{[\text{NOAEL} \times \text{SSF}] \times Wt_A}{F_A}$$

where:

- WV_{fish} = wildlife value for fish tissue (mg/kg);
- NOAEL = no-observed-adverse-effect level (mg/kg-day);
- SSF = species sensitivity factor
- Wt_A = average weight of animal in kilograms (kg); and
- F_A = average daily amount of food consumed (kg/day).

Secondly, the geometric mean of the wildlife values was calculated for the mammal group, as well as for the avian group. Finally, the lower of the two geometric mean values was considered the wildlife criterion for fish tissue for a given chemical.

It should be noted that direct ingestion of surface water was included when developing proposed EPA wildlife criteria for surface water. This exposure route, however, was not considered when evaluating NSI data, even though sediment contamination might result in contamination of surface water available for wildlife consumption. A sensitivity analysis was conducted to evaluate the impact of excluding the surface water ingestion exposure route. Based on this analysis, ingestion of surface water contributes less than 0.0001 percent of the total exposure (i.e., ingestion of fish and water). Therefore, excluding the water ingestion exposure route had no significant impact on the evaluation of NSI data with regard to potential wildlife impacts.

Wildlife criteria derived for DDT, mercury, 2,3,7,8-TCDD, and PCBs based on fish tissue concentration are presented below.

<u>Chemical</u>	<u>Fish Tissue Criterion (mg/kg)</u>
DDT	3.93E-2
Mercury	5.73E-2
2,3,7,8-TCDD	5.20E-7
PCBs	1.60E-1

The wildlife criteria were compared to measured fish tissue residue data contained in the NSI and to TBPs calculated for DDT, 2,3,7,8-TCDD, and PCBs. Mercury is not a nonpolar organic chemical, and thus a TBP for mercury was not calculated. A whole-body lipid value of 10.31 was assumed for the TBP evaluation of potential wildlife impacts, based on the *Great Lakes Water Quality Technical Support Document for the Procedure to Determine Bioaccumulation Factors* (USEPA, 1995b).

References

- Adams, W.J., R.A. Kimerle, and R.G. Mosher. 1985. Aquatic safety assessment of chemicals sorbed to sediments. In *Aquatic Toxicology and Hazard Assessment: Seventh Annual Symposium, American Society for Testing and Materials, Philadelphia, PA*, ed. R.D. Cardwell, R. Purdy, and R.C. Bahner, pp. 429-453.
- Adams, W.J., R.A. Kimerle, and J.W. Barnett, Jr. 1992. Sediment quality and aquatic life. *Environ. Sci. Technol.*, 26:1865-1875.
- Allen, H.E., G. Fu, and B. Deng. 1993. Analysis of acid-volatile sulfide (AVS) and simultaneously extracted metals (SEM) for the estimation of potential toxicity in aquatic sediments. *Environ. Toxicol. Chem.* 12:1441-1453.
- Ankley, G.T., V.R. Mattson, E.N. Leonard, C.W. West, and J.L. Bennett. 1993. Predicting the toxicity of copper in freshwater sediments: Evaluation of the role of acid-volatile sulfide. *Environ. Toxicol. Chem.* 12:315-320.
- API. 1994. *User's guide and technical resource document: Evaluation of sediment toxicity tests for biomonitoring programs*. API pub. no. 4607. Prepared for American Petroleum Institute, Health and Environmental Sciences Department, Washington, D.C., by PTI Environmental Services, Bellvue, WA.
- Barrick, R., S. Becker, L. Brown, H. Beller, and R. Pastorok. 1988. *Sediment quality values refinement: 1988 update and evaluation of Puget Sound AET*. Vol. 1. Prepared for the Puget Sound Estuary Program, Office of Puget Sound.
- Bierman, V.J. 1990. Equilibrium partitioning and magnification of organic chemicals in benthic animals. *Environ. Sci. Technol.* 24:1407-1412.
- Burton, G.A., Jr., J.K. Nelson, and C.G. Ingersoll. 1992. Freshwater benthic toxicity tests. In *Sediment toxicity assessment*, ed. G.A. Burton, Jr., pp. 213-240. Lewis Publishers, Chelsea, MI.
- Casas, A.M., and E.A. Crecelius. 1994. Relationship between acid-volatile sulfide and the toxicity of zinc, lead and copper in marine sediments. *Environ. Toxicol. Chem.* 13(3):529-536.
- de Bruijn, J., F. Busser, W. Seinen, and J. Hermens. 1989. Determination of octanol/water partition coefficients for hydrophobic organic chemicals with the "slow-stirring" method. *Environ. Toxicol. Chem.* 8:499-512.
- De Kock, A.C., and D.A. Lord. 1987. A simple procedure for determining octanol-water partition coefficients using reverse phase high performance liquid chromatography (RPHPLC). *Chemosphere* 16(1):133-142.
- Di Toro, D.M., J.D. Mahony, D.J. Hansen, K.J. Scott, M.B. Hicks, S.M. Mays, and M.S. Redmond. 1990. Toxicity of cadmium in sediments: The role of acid-volatile sulfide. *Environ. Toxicol. Chem.* 9:1487-1502.
- Di Toro, D.M., J.D. Mahony, D.J. Hansen, K.J. Scott, A.R. Carlson, and G.T. Ankley. 1992. Acid-volatile sulfide predicts the acute toxicity of cadmium and nickel in sediments. *Environ. Sci. Technol.* 26(1):96-101.
- Di Toro, D.M., C.S. Zarba, D.J. Hansen, W.J. Berry, R.C. Swartz, C.E. Cowan, S.P. Pavlou, H.E. Allen, N.A. Thomas, and P.R. Paquin. 1991. Technical basis for establishing sediment quality criteria for nonionic organic chemicals using equilibrium partitioning. *Environ. Toxicol. Chem.* 10:1541-1583.
- Doucette, W.J., and A.W. Andren. 1988. Estimation of octanol/water partition coefficients: evaluation of six methods for highly hydrophobic aromatic hydrocarbons. *Chemosphere* 17(2):345-359.
- FDEP. 1994. *Approach to the assessment of sediment quality in Florida coastal waters, Vol. 1. Development and*

- evaluation of sediment quality assessment guidelines*. Prepared for Florida Department of Environmental Protection, Office of Water Policy, Tallahassee, FL, by MacDonald Environmental Sciences Ltd., Ladysmith, British Columbia.
- Geyer, H., P. Sheehan, D. Kotzias, and F. Korte. 1982. Prediction of ecological behavior of chemicals: Relationship between physico-chemical properties and bioaccumulation of organic chemicals in the mussel *Mytilus edulis*. *Chemosphere* 11:1121-1134.
- Hansen, D.J. 1995. Assessment tools that can be used for the National Sediment Inventory. Memorandum from D.J. Hansen, Environmental Research Laboratory, Narragansett, to C. Fox, USEPA Office of Water, February 28, 1995.
- Harkey, G.A., P.F. Landrum, and S.J. Klaine. 1994. Comparison of whole-sediment, elutriate and pore-water exposures for use in assessing sediment-associated organic contaminants in bioassays. *Environ. Contam. Toxicol.* 13(8):1315-1329.
- Howard, P.H. 1990. *Handbook of environmental fate and exposure data for organic chemicals*. Vol. II. Solvents. Lewis Publishers, Chelsea, MI.
- Howard, D.E., and R.D. Evans. 1993. Acid-volatile sulfide (AVS) in a seasonally anoxic mesotrophic lake: Seasonal and spatial changes in sediment AVS. *Environ. Toxicol. Chem.* 12:1051-1057.
- Ingersoll, C.G., P.S. Haverland, E.L. Brunson, T.J. Canfield, F.J. Dwyer, C.E. Henke, and N.E. Kemble. 1996. Calculation and evaluation of sediment effect concentrations. *J. Great Lakes Res.* 22:602-623.
- Isnard, P., and S. Lambert. 1989. Aqueous solubility and n-octanol/water partition coefficient correlations. *Chemosphere* 18:1837-1853.
- Karickhoff, S. 1981. Semi-empirical estimation of sorption of hydrophobic pollutants on natural sediments and soils. *Chemosphere* 9:3-10.
- Karickhoff, S. W., and J.M. Long. 1995. Internal report on summary of measured, calculated, and recommended log K_{ow} values. Prepared for U.S. Environmental Protection Agency, Office of Water, Washington, DC.
- Klein, W., W. Kordel, M. Weis, and H.J. Poremski. 1988. Updating of the OECD test guideline 107 "partition coefficient n-octanol/water": OECD laboratory intercomparison test on the HPLC method. *Chemosphere* 17(2):361-386.
- Konemann, H., and K. van Leeuwen. 1980. Toxicokinetics in fish: Accumulation and elimination of six chlorobenzenes by guppies. *Chemosphere* 9:3-19.
- Lamberson, J.O., T.H. DeWitt, and R.C. Swartz. 1992. Assessment of sediment toxicity to marine benthos. In *Sediment toxicity assessment*, ed. G.A. Burton, Jr., pp. 183-211. Lewis Publishers, Chelsea, MI.
- Leo, A.J. 1993. Calculating log P_{oct} from structures. *Chem. Rev.* 93:1281-1310.
- Long, E.R., D.D. MacDonald, S.L. Smith, and F.D. Calder. 1995. Incidence of adverse biological effects within ranges of chemical concentrations in marine and estuarine sediments. *Environ. Manage.* 19(1):81-97.
- Long, E.R., and L.G. Morgan. 1990. *The potential for biological effects of sediment-sorbed contaminants tested in the National Status and Trends Program*. NOAA tech. mem. NOS OMA 52. National Oceanic and Atmospheric Administration, Seattle, WA.
- Long, E.R., L.J. Field, and D.D. MacDonald. In press. Predicting toxicity in marine sediments with numerical

- sediment quality guidelines. Submitted to *Environ. Toxicol. Chem.*
- Luoma, S.N. 1983. Bioavailability of trace metals to aquatic organisms—A review. *Sci. Tot. Environ.* 28:1-22.
- Mackay, D. 1982. Correlation of bioconcentration factors. *Environ. Sci. Technol.* 5:274-278.
- . 1991. *Multimedia environmental models: The fugacity approach*. Lewis Publishers, Boca Raton, FL.
- Mackay, D., W.Y. Shiu, and K.C. Ma. 1992a. *Illustrated handbook of physical-chemical properties and environmental fate for organic chemicals. Volume II, Polynuclear aromatic hydrocarbons, polychlorinated dioxins and dibenzofurans*. Lewis Publishers, Boca Raton, FL.
- Mackay, D., W.Y. Shiu, and K.C. Ma. 1992b. *Illustrated handbook of physical-chemical properties and environmental fate for organic chemicals. Volume I, Monoaromatic hydrocarbons, chlorobenzenes, and PCBs*. Lewis Publishers, Boca Raton, FL.
- Meyer, J.S., W. Davison, B. Sundby, J.T. Ores, D.J. Lauren, U. Forstner, J. Hong, and D.G. Crosby. 1994. Synopsis of discussion session: The effects of variable redox potentials, pH, and light on bioavailability in dynamic water-sediment environments. In *Bioavailability physical, chemical, and biological interactions*, proceedings of the Thirteenth Pellston Workshop, ed. J.L. Hamelink, P.F. Landrum, H.L. Bergman, and W.H. Benson, pp.155-170. Lewis Publishers, Boca Raton, FL.
- Noble, A. 1993. Partition coefficients (*n*-octanol-water) for pesticides. *J. Chromatography* 642:314.
- Stephan, C.E. 1993. *Derivation of proposed human health and wildlife bioaccumulation factors for the Great Lakes initiative*. U.S. Environmental Protection Agency, Office of Research and Development, Duluth, MN.
- Suter, G.W.II, and J.B. Mabrey. 1994. *Toxicological benchmarks for screening potential contaminants of concern for effects on aquatic biota: 1994 revision*. ES/ER/TM-96/R1. Oak Ridge National Laboratory, Environmental Sciences Division, Oak Ridge, TN.
- Thomas, N., J.O. Lamberson, and R.C. Swartz. 1992. Bulk sediment toxicity test approach. In *Sediment classification methods compendium*, pp. 3-1-3-10. EPA 823-R-92-006. U.S. Environmental Protection Agency, Office of Water, Washington, DC.
- USEPA. 1985. *Guidelines for deriving numerical national water quality criteria for the protection of aquatic organisms and their uses*. PB85-227049. National Technical Information Service, Springfield, VA.
- . 1989. *Risk assessment guidance for Superfund. Volume I: Human health evaluation manual (Part A)*. Interim final. OSWER Directive 9285.7-01a. U.S. Environmental Protection Agency, Office of Solid Waste and Emergency Response, Washington, DC. December 1989.
- . 1990. National contingency plan. *Federal Register*, March 8, 1990, 55:8666.
- . 1992a. *Sediment classification methods compendium*. EPA 823-R-92-006. U.S. Environmental Protection Agency, Office of Water, Washington, DC.
- . 1992b. *National study of chemical residues in fish*. 2 vols. EPA 823-R-92-008a,b. U.S. Environmental Protection Agency, Office of Science and Technology, Washington, DC.
- . 1993a. *Technical basis for establishing sediment quality criteria for nonionic organic contaminants for the protection of benthic organisms by using equilibrium partitioning*. Draft. EPA 822-R-93-011. U.S. Environmental Protection Agency, Office of Science and Technology, Health and Ecological Criteria Division, Washington, DC.

- . 1993b. *Proposed sediment quality criteria for the protection of benthic organisms: Acenaphthene*. EPA 822/R93-013. U.S. Environmental Protection Agency, Office of Science and Technology, Health and Ecological Criteria Division, Washington, DC.
- . 1993c. *Proposed sediment quality criteria for the protection of benthic organisms: Dieldrin*. EPA 822/R93-015. U.S. Environmental Protection Agency, Office of Science and Technology, Health and Ecological Criteria Division, Washington, DC.
- . 1993d. *Proposed sediment quality criteria for the protection of benthic organisms: Endrin*. EPA 822/R93-016. U.S. Environmental Protection Agency, Office of Science and Technology, Health and Ecological Criteria Division, Washington, DC.
- . 1993e. *Proposed sediment quality criteria for the protection of benthic organisms: Fluoranthene*. EPA 822/R93-012. U.S. Environmental Protection Agency, Office of Science and Technology, Health and Ecological Criteria Division, Washington, DC.
- . 1993f. *Proposed sediment quality criteria for the protection of benthic organisms: Phenanthrene*. EPA 822/R93-015. U.S. Environmental Protection Agency, Office of Science and Technology, Health and Ecological Criteria Division, Washington, DC.
- . 1994a. *Guidance for assessing chemical contamination data for use in fish advisories, Volume II: Development of Risk - Based Intake Limits*. U.S. Environmental Protection Agency, Office of Science and Technology, Washington, DC.
- . 1994b. *Methods for measuring the toxicity and bioaccumulation of sediment-associated contaminants with estuarine and marine amphipods*. EPA 600/R-94/025. U.S. Environmental Protection Agency, Office of Research and Development, Washington, DC.
- . 1994c. *Methods for measuring the toxicity and bioaccumulation of sediment-associated contaminants with freshwater invertebrates*. EPA 600/R-94/024. U.S. Environmental Protection Agency, Office of Research and Development, Duluth, MN.
- . 1995a. *Great Lakes Water Quality Initiative criteria documents for the protection of wildlife*. EPA-820-B-95-008. U.S. Environmental Protection Agency, Office of Science and Technology, Washington, DC.
- . 1995b. *Great Lakes Water Quality Initiative technical support document for the procedure to determine bioaccumulation factors*. EPA-820-B-95-005. U.S. Environmental Protection Agency, Office of Water, Washington, DC.
- . 1995c. *Water quality guidance for the Great Lakes System: Supplementary information document (SID)*. EPA-820-B-95-001. U.S. Environmental Protection Agency, Office of Water, Washington, DC.
- USEPA and USACOE. 1994. *Evaluation of dredged material proposed for discharge in waters of the U.S.—Testing manual (draft)*. EPA-823-B-94-002. U.S. Environmental Protection Agency, Office of Water, and U.S. Army Corps of Engineers, Washington, DC.
- Zhuang, Y., H.E. Allen, and G. Fu. 1994. Effect of aeration of sediment on cadmium binding. *Environ. Toxicol. Chem.* 13(5):717-724.

Appendix C

Method for Selecting Biota-Sediment Accumulation Factors and Percent Lipids in Fish Tissue Used for Deriving Theoretical Bioaccumulation Potentials

Theoretical bioaccumulation potentials (TBPs) are empirically derived potential concentrations that might occur in the tissues of fish exposed to contaminated sediments. TBPs are computed for nonpolar organic chemicals as a function of sediment concentrations, fish tissue lipid contents, and sediment organic carbon contents. Four separate pieces of information are required to compute the TBP for nonpolar organic chemicals:

1. Concentration of nonpolar organic compound in sediment.
2. Organic carbon content of the sediment.
3. Biota-sediment accumulation factor (BSAF).
4. Lipid content in fish tissue.

The details of the TBP calculations and related assumptions are found in Appendix B of this report to Congress. This appendix describes the approach used to develop the BSAFs used in the NSI TBP evaluation and to evaluate fish tissue lipid content data from selected information sources for comparison to the values used in the NSI TBP evaluation. The BSAF values used for each chemical evaluated are presented in Appendix D.

Chemicals considered for fish tissue residue evaluation as part of the NSI data evaluation have at least one screening value available, and the sum of positive sediment results and positive tissue results is greater than 20 observations. BSAF values were assigned to all nonpolar organic chemicals in the NSI having available screening values. These screening values are risk-based concentrations (RBCs) developed either from carcinogenic potency slopes or from oral reference doses. Carcinogenic potency slopes and reference doses were obtained from IRIS (USEPA, 1995) and HEAST (USEPA, 1994b). Other screening values used for comparison to TBP values and tissue data are U.S. Food and Drug Administration (FDA) tolerance/action/guidance levels and EPA wildlife criteria. The BSAF values used in the analysis are presented in Appendix D along with the screening values discussed above.

Method for Selecting BSAFs

Biota-sediment accumulation factors (BSAFs) are transfer coefficients that relate concentrations in biota to concentrations in sediment. They are calculated as the ratio of the concentration of nonpolar organic chemical in fish tissue (normalized by lipid content) to the concentration of nonpolar organic chemical in sediment (normalized by organic carbon content). At equilibrium, BSAFs are in theory approximately 1.0. In practice, BSAFs can be greater than or less than 1.0 depending on the disequilibrium between fish and water, and that between water and sediment. Although based on partitioning theory, field measured BSAFs empirically account for factors such as metabolism and

food chain biomagnification. BSAFs can vary depending on the biota, dynamics of chemical loadings to the water body, food chain effects, and rate of sediment-water exchange. Thus, measured BSAF values will depend on many site-specific variables including hydraulic, biological, chemical, and ecological factors that affect bioavailability. The accuracy of a BSAF, measured at one location at a point in time, when applied to another location at another point in time depends on two factors: (1) the degree to which variation from a theoretical BSAF of 1.0 is controlled by inherent properties of the chemical as opposed to environmental conditions of the locale, and (2) the degree of similarity between environmental conditions at the place of measurement and place of application.

BSAF values were assigned only to nonpolar chemicals in the NSI. This section describes how the BSAF values used for the TBP assessment were selected from recommended values for specific chemicals.

Sources of Recommended BSAFs

BSAFs used in the NSI TBP evaluation were obtained from the EPA Office of Research and Development (EPA/ORD) Environmental Research Laboratories at Duluth, Minnesota (Cook, 1995) and Narragansett, Rhode Island (Hansen, 1995). In some cases (i.e., EPA/ORD-Duluth), BSAFs were provided for specific chemicals; in other cases (i.e., EPA/ORD-Narragansett), BSAFs were provided by chemical class. Recommended BSAFs from each laboratory are described below.

EPA Environmental Research Laboratory, Duluth

BSAF recommendations obtained from EPA/ORD-Duluth included mainly chemical-specific values for:

- PCB congeners
- Pesticides
- Dioxins/Furans
- Chlorinated benzenes

The recommended values from EPA/ORD-Duluth were based on BSAF data compiled from various sites and studies. Data were selected based on the following criteria (Cook, 1995):

- The primary source of chemical exposure to food webs was through release of chemicals in sediments.
- The BSAF was derived for pelagic organisms (i.e., fish).
- Chemicals in sediments and biota were at roughly steady state with respect to environmental loadings of the chemical.

Pelagic BSAF data which predict relative bioaccumulation potentials of different chemicals are available for ecosystems in which sediments are a primary source of the chemicals to pelagic food webs through release of chemicals to the water. Little or no BSAF data exist for sites in which water and sediments are at steady-state with respect to external chemical loadings. The best BSAF data for fish are those measured for Lake Ontario and used to estimate BSAFs in the Technical Support Document (TSD) for the Great Lakes Water Quality Initiative (GLWQI) (Cook, 1995; Cook et al., 1994; USEPA, 1994a). The lake Ontario BSAFs are based on a large set of sediment and fish samples collected in 1987 (USEPA, 1990). The BSAFs for PCDDs, PCDFs and co-planar PCB congeners are available from ORD-Duluth data. Additional BSAFs for PCBs and pesticides are available from the data of Oliver and Niimi (1988). These contemporary BSAFs are estimated to be approximately 20 to 25 percent of BSAFs when Lake Ontario surface sediments and water are at steady-state with chemical loading to the ecosystem; a condition which probably existed in the 1960s. EPA has measured BSAFs in the Fox River and Green Bay in Wisconsin and find similar values despite much different species and exposure conditions (Cook, 1995).

EPA Environmental Research Laboratory, Narragansett

EPA/ORD-Narragansett provided a second source of information for selecting BSAF values. Probability distribution curves for selecting BSAFs were presented by EPA/ORD-Narragansett for three chemical classes:

- PAHs
- PCBs
- Pesticides

EPA/ORD-Narragansett researchers developed cumulative probability curves for each chemical class from their database of BSAFs (Hansen, 1995). The database from which general BSAF recommendations were summarized included data from laboratory and field studies conducted with both freshwater and marine sediments. Data must be from species that directly contact sediments or feed on organisms that live in sediments, i.e., benthic invertebrates and benthically coupled fishes.

Overall the database contained more than 4,000 BSAF observations. Cumulative probability curves summarizing the BSAF data in the database were provided by Hansen (1995) for PAHs, PCBs, and pesticides. BSAF values were tabulated for several probability percentiles. These findings have been published in Tracey and Hansen, 1996.

Approach for Selecting BSAFs from Recommended Values

The general approach for selecting a BSAF for a chemical follows:

- Use a chemical-specific value for the BSAF, if available.
- If no chemical-specific value is available, use a BSAF derived for a chemical category.
- For chemicals having no specific information on the BSAF, use a default value of 1.

The EPA/ORD-Narragansett values for the BSAF were selected as the 50th percentile of the distribution of BSAFs by chemical class (Table C-1). The BSAF values from EPA/ORD-Duluth were averages of individual data points for specific chemicals. The preference for central tendency measures reflects risk management that implies an approximate 50 percent chance of bioaccumulation to a predicted level. Other components of the EPA risk levels for fish tissue chemical residues and FDA action/tolerance/guidance, such as toxic potency (cancer potency factor and oral reference doses) and exposure frequency, reflect more precautionary and protective risk management.

Because there was some overlap between the categories of chemicals for which BSAF values were recommended, the following approach was used to assign BSAFs to specific chemicals in the NSI (Table C-2). For dioxins and furans, chemical-specific values recommended by EPA/ORD-Duluth were applied; for PCBs, the value for total PCBs recommended by EPA/ORD-Duluth was used. When using BSAFs from USEPA (1994a), values from the study by Cook et al. (1994) were preferred over values reported by Oliver and Niimi (1988).

Pesticides received recommendations from both laboratories. The BSAFs developed by EPA/ORD-Narragansett were for benthic organisms and demersal (bottom-dwelling) fishes. The BSAFs developed by EPA/ORD-Duluth, on

Table C-1. EPA/ORD-Narragansett Data BSAF Distributions (kg sediment organic carbon/kg lipid)

Probability Percentile	Chemical Class		
	PAHs	PCBs	Pesticides
50	0.29	1.11	1.80
70	0.55	2.26	3.34
80	0.94	3.66	4.61
90	1.71	5.83	7.31
95	2.84	9.15	10.61
100	4.19	16.46	22.63

Table C-2. Conventions for Assigning BSAFs to Nonpolar Organic Compounds in NSI

Category of Chemical	Source of BSAF	BSAF Value Used in Evaluation
Dioxins	EPA/ORD-Duluth ^a "pelagic" chemical-specific BSAF	0.059
PCBs	EPA/ORD-Duluth ^a "pelagic" BSAF for total PCBs	1.85
Pesticides	log $K_{ow} < 5.5$ EPA/ORD-Narragansett ^b "benthic" class-specific BSAF for 50th percentile protection level	1.80
	log $K_{ow} \geq 5.5$ EPA/ORD-Duluth ^a "pelagic" chemical-specific BSAF if available; otherwise, use EPA/ORD-Narragansett ^b value	See chemical-specific BSAF given in Appendix D
PAHs	EPA/ORD-Narragansett ^b "benthic" class-specific BSAF for 50th percentile protection level	0.29
Halogenated and other compounds	Default value of 1 unless chemical-specific value available from EPA/ORD-Duluth ^a	1.0

^aCook, 1995.^bHansen, 1995.

the other hand, were for benthically coupled pelagic (open-water) fishes. BSAFs from EPA/ORD-Narragansett were used for pesticides having log K_{ow} values less than 5.5. For pesticides having log K_{ow} values greater than or equal to 5.5, the BSAF values from EPA/ORD-Duluth were used. BSAF values selected by this approach are more appropriate because food web transfer to pelagic fishes is considered to be a more important process for chemicals having high log K_{ow} values. Exposure through environmental media, as in direct contact with sediments by benthic organisms, is a more important process for chemicals having low log K_{ow} values. Chemicals having no recommended BSAF values available were assigned a default BSAF of 1.

Evaluation of Tissue Lipid Content

Fish tissue lipid content enters the risk screening assessment as the normalizing factor in the numerator of the TBP equation. Normalizing by organic carbon content removes much of the site-to-site variation in the sorption of nonpolar organic chemicals by sediments (Karickhoff et al., 1979). In a similar manner, normalizing by lipid content can eliminate much site and species variation in the tendency of organisms to bioaccumulate nonpolar organic compounds (Esser, 1986). Lipid contents can vary naturally with species, site, season, age and size of fish, and trophic level. In addition, reported lipid contents can vary significantly depending on the analytical method (Randall et al., 1991).

The purpose of this section is to evaluate the percent fish lipid content data from various sources and compare these values to those selected for use in the NSI evaluation (i.e., 3.0 percent for filets for human health TBP evaluations and 10.31 for whole body wildlife TBP evaluations).

The remainder of this section describes the lipid data sources evaluated and analysis of the lipid content data.

Sources of Lipid Data

Lipid data used for comparison with the percent lipid values selected for the NSI evaluation were obtained from three major sources:

- EPA's water monitoring database, STORET.
- *National Study of Chemical Residues in Fish*, or NSCRF (USEPA, 1992).
- U.S. Department of Agriculture's (USDA's) *Composition of Foods* (Dickey, 1990).

Additional sources included examples of whole fish and fillet lipid contents taken from the recent literature.

Each of the three major sources is described in the following paragraphs.

STORET

The STORET database was the single largest source of reported data on fish tissue lipid contents. Data stored under various parameter codes for lipid content in STORET were converted into units of percentage. Some screening of the data was performed as follows:

- Records were retrieved from January 1990 to March 1995.
- Reported lipid contents greater than 35 percent were eliminated because they were significantly greater than the 90th percentile.
- Only records having an anatomy code of "whole organism" or "fillet" were included. Records with a code of "fillet/skin" or "edible portion" were excluded.
- Data that appeared to be reversed (i.e., fillet percent lipid was greater than whole organism lipid) were also not considered.
- Also not considered were records in which the minimum and maximum were equal, or very nearly equal, when the number of observations was large.

There is less consistency in the data obtained from STORET relative to the NSCRF data because the analyses in STORET were conducted by numerous laboratories around the Nation. Data reported under different parameter codes (i.e., different methods for lipids) were grouped for the analysis. Moreover, the quality of the data in STORET is unknown. STORET data are compiled by species in Table C-3. The fishes are divided by trophic level and habitat into four subtables (Tables C-3a through C-3d) for the combinations of trophic levels 3 and 4 and epibenthic (bottom-dwelling) and pelagic (water column-dwelling) habitat.

National Study of Chemical Residues in Fish

The second largest database on fish tissue lipid content was available from the NSCRF (USEPA, 1992) (Table C-3). This set of lipid analysis data was taken in conjunction with analyses for dioxins/furans. An advantage of this database is that all of the lipid measurements were performed by the same laboratory using the same method. The data were screened to exclude data for fish species for which two or fewer observations were made.

USDA Report on Composition of Foods

A summary of a relatively small database on the composition of fish and shellfish foods and food products was available from USDA (Dickey, 1990). The section on fish and shellfish in the report coordinated by Dickey (1990) came from an earlier USDA report by Exler (1987). Data presented by Exler (1987) for various fish species were summarized from the USDA's Nutrient Data Bank (NDB). Records in the NDB are based primarily on published scientific reports and technical journal articles. To a lesser extent, the NDB contains unpublished data from industrial, government, and academic institutions under contract with the Human Nutrition Information Service. Lipids data are given in percentage of edible portion, where "edible portion" is the part of food customarily considered edible in the United States. Records were available for 32 fishes.

Table C-3a. Lipid Contents of Trophic Level 3, Epibenthic Fishes

Species Name	Common Name	Whole Fish Lipid Content, Percent (size)	Fillet Lipid Content, Percent (size)	Reference, Comments
<i>Aplodinotus grunniens</i>	freshwater drum		mean = 1.9 (1.3 to 2.5, 3 obs)	EPA (1992)
<i>Aplodinotus grunniens</i>	freshwater drum		mean = 4.93, standard (error = 0.103, 905 obs)	Exler (1987)
<i>Carpoides carpio</i>	river carpsucker	mean = 5.8 (0.5 to 15.0, 3865 obs)	mean = 4.4 (1.8 to 9.2, 184 obs)	STORET
<i>Carpoides cyprinus</i>	quillback	mean = 5.1 (0.3 to 13.0, 780 obs)	mean = 3.2 (0.4 to 4.89, 78 obs)	STORET
<i>Catostomus ardens</i>	Utah sucker	mean = 3.5 (1.1 to 8.2, 356 obs)	mean = 1.6 (0.1 to 6.7, 695 obs)	STORET
<i>Catostomus catostomus</i>	longnose sucker (FW)		0.8 to 3.8 (not given)	Owens et al. (1994)
<i>Catostomus catostomus</i>	longnose sucker	mean = 3.9 (2.5 to 7.2, 298 obs)	mean = 7.05 (6.4 to 7.7, 32 obs)	STORET
<i>Catostomus columbianus</i>	bridgelip sucker	mean = 4.6 (0.7 to 10.4, 309 obs)		STORET
<i>Catostomus commersoni</i>	white sucker		5.41 ± 1.18 1.07 ± 0.23 1.36 ± 0.17 0.99 ± 0.22 2.25 ± 0.65 (not given)	Servos et al. (1994)
<i>Catostomus commersoni</i>	white sucker	mean = 6.1 (1.4 to 21.8, 39 obs)		USEPA (1992)
<i>Catostomus commersoni</i>	white sucker	mean = 4.3 (0.2 to 12.0, 4102 obs)	mean = 1.7 (0.2 to 9.1, 586 obs)	STORET
<i>Catostomus commersoni</i>	white sucker		mean = 2.32 (standard error = 0.069, 157 obs)	Exler (1987)
<i>Catostomus macrocheilus</i>	largescale sucker	mean = 6.7 (0.3 to 13.0, 752 obs)	mean = 1.6 (0.1 to 5.26, 482 obs)	STORET
<i>Catostomus occidentalis</i>	Sacramento sucker	mean = 9.8 (1.7 to 18.5, 3 obs)		USEPA (1992)
<i>Cottus cognatus</i>	sculpin (FW)	8 (5.4 g)		USEPA (1994a)
<i>Cyprinus carpio</i>	carp	9 (15 g)		Cook et al. (1991)
<i>Cyprinus carpio</i>	carp	18.7 (69.5 g) 15.7 (56.0 g) 13.0 (37.5 g) 16.6 (36.5 g) 17.5 (29.0 g)		Kuehl et al. (1987)

Table C-3a. (Continued)

Species Name	Common Name	Whole Fish Lipid Content, Percent (size)	Fillet Lipid Content, Percent (size)	Reference, Comments
<i>Cyprinus carpio</i>	carp	18.7 (69.5 g) 15.7 (56.0 g) 13.0 (37.5 g) 16.6 (36.5 g) 17.5 (29.0 g)		Kuehl et al. (1987)
<i>Cyprinus carpio</i>	carp	mean = 9.3 (0.5 to 25.1, 145 obs)	mean = 9.0 (2.0 to 19.6, 6 obs)	USEPA (1992)
<i>Cyprinus carpio</i>	carp	mean = 6.5 (0.3 to 17.0, 70002 obs)	mean = 4.3 (0.02 to 21.6, 16139 obs)	STORET
<i>Cyprinus carpio</i>	carp		mean = 5.60 (standard error = 0.207, 163 obs)	Exler (1987)
<i>Ctenopharyngodon idella</i>	grass carp		mean = 5.2 (3 obs)	USEPA (1992)
<i>Erimyzon oblongus</i>	creek chubsucker	mean = 3.9 (3.9 to 4.0, 3 obs)		USEPA (1992)
<i>Hypentelium nigricans</i>	northern hogsucker	mean = 4.4 (0.8 to 8.98, 637 obs)	mean = 0.7 (0.5 to 0.99, 70 obs)	STORET
<i>Ictalurus furcatus</i>	blue catfish	mean = 7.3 (5.3 to 10.4, 5 obs)	mean = 2.7 (2.0 to 3.0, 4 obs)	USEPA (1992)
<i>Ictalurus furcatus</i>	blue catfish		mean = 6.0 (1.5 to 12.0, 56 obs)	STORET
<i>Ictalurus melas</i> (<i>Ameiurus melas</i>)	black bullhead	mean = 2.9 (0.9 to 6.2, 911 obs)	mean = 1.4 (0.15 to 5.1, 573 obs)	STORET
<i>Ictalurus natalis</i> (<i>Ameiurus natalis</i>)	yellow bullhead	mean = 2.8 (0.5 to 7.5, 235 obs)	mean = 0.96 (0.1 to 3.2, 294 obs)	STORET
<i>Ictalurus nebulosus</i> (<i>Ameiurus nebulosus</i>)	brown bullhead	mean = 2.2 (1.3 to 4.1, 133 obs)	mean = 1.5 (0.4 to 3.3, 107 obs)	STORET
<i>Ictalurus punctatus</i>	channel catfish	mean = 9.8 (3.4 to 23.0, 22 obs)	mean = 5.1 (1.1 to 11.5, 17 obs)	USEPA (1992)
<i>Ictalurus punctatus</i>	channel catfish	mean = 7.1 (0.3 to 15.0, 7512 obs)	mean = 5.1 (0.2 to 17.3, 20655 obs)	STORET
<i>Ictalurus punctatus</i>	channel catfish		mean = 4.26 (standard error = 0.417, 59 obs)	Exler (1987)
<i>Ictiobus bubalus</i>	smallmouth buffalo	mean = 5.7 (2.2 to 11.9, 6 obs)		USEPA (1992)

Table C-3a. (Continued)

Species Name	Common Name	Whole Fish Lipid Content, Percent (size)	Fillet Lipid Content, Percent (size)	Reference, Comments
<i>Ictiobus bubalus</i>	smallmouth buffalo	mean = 9.7 (2.8 to 17.3, 886 obs)	mean = 4.8 (0.2 to 14.5, 595 obs)	STORET
<i>Ictiobus cyprinellus</i>	bigmouth buffalo	mean = 15.1 (5.7 to 22.6, 3 obs)		USEPA (1992)
<i>Ictiobus cyprinellus</i>	bigmouth buffalo	mean = 5.8 (0.4 to 16.2, 675 obs)	mean = 4.1 (0.3 to 15, 1678 obs)	STORET
<i>Ictiobus niger</i>	black buffalo		mean = 3.5 (1.2 to 7.1, 42 obs)	STORET
<i>Minytrema melanops</i>	spotted sucker	mean = 4.5 (0.9 to 7.4, 9 obs)		USEPA (1992)
<i>Minytrema melanops</i>	spotted sucker	mean = 3.7 (0.7 to 5.9, 188 obs)	mean = 1.5 (0.9 to 3.2, 197 obs)	STORET
<i>Moxostoma anisurum</i>	silver redbhorse	mean = 8.2 (6.2 to 8.5, 180 obs)	mean = 2.1 (1.3 to 2.7, 7 obs)	STORET
<i>Moxostoma carinatum</i>	river redbhorse	mean = 5.1 (1.9 to 5.9, 193 obs)	mean = 1.3 (0.5 to 2.4, 170 obs)	STORET
<i>Moxostoma duquesnei</i>	black redbhorse	mean = 5.0 (0.3 to 9.7, 1774 obs)	mean = 0.97 (0.7 to 1.8, 58 obs)	STORET
<i>Moxostoma erythrum</i>	golden redbhorse	mean = 6.0 (0.8 to 16.1, 2018 obs)	mean = 1.8 (0.6 to 2.8, 154 obs)	STORET
<i>Moxostoma macrolepidotum</i>	shorthead redbhorse	mean = 19.8 (10.8 to 31.9, 4 obs)		USEPA (1992)
<i>Moxostoma macrolepidotum</i>	shorthead redbhorse	mean = 6.5 (0.4 to 10.9, 683 obs)	mean = 3.0 (1.4 to 13.5, 342 obs)	STORET
<i>Mugil cephalus</i>	striped mullet		mean = 3.79 (standard error = 0.357, 43 obs)	Exler (1987)
<i>Mylocheilus caurinus</i>	peamouth	mean = 11.0 (9.36 to 12.91, 162 obs)		STORET
<i>Ptychocheilus oregoni</i>	northern squawfish	mean = 5.6 (0.8 to 12.0, 812 obs)	mean = 1.3 (0.7 to 3.0, 117 obs)	STORET
<i>Ptychocheilus</i>	squawfish		mean = 2.2 (0.5 to 3.0, 7 obs)	USEPA (1992)
<i>Scaphirhynchus platyrhynchus</i>	shovelnose sturgeon		mean = 7.4 (1.1 to 20.3, 392 obs)	STORET

Table C-3b. Lipid Contents of Trophic Level 3, Pelagic Fishes

Species Name	Common Name	Whole Fish Lipid Content, Percent (size)	Fillet Lipid Content, Percent (size)	Reference, Comments
<i>Acipenser</i> sp.	sturgeon (unknown)		mean = 4.04 (7 obs)	Exler (1987)
<i>Acrocheilus alutaceus</i>	chiselmouth	mean = 5.0 (3.2 to 6.8, 47 obs)	mean = 0.55 (0.19 to 1.00, 91 obs)	STORET
<i>Alosa pseudoharengus</i>	alewife	7 (32 g)		USEPA (1994a)
<i>Alosa pseudoharengus</i>	alewife	mean = 8.9 (3.7 to 15.2, 128 obs)		STORET
<i>Alosa sapidissima</i>	American shad	mean = 6.55 (5.9 to 7.6, 270 obs)		STORET
<i>Alosa sapidissima</i>	American shad		mean = 13.77 (standard error = 1.00, 11 obs)	Exler (1987)
<i>Anguilla rostrata</i>	American eel		mean = 11.66 (standard error = 0.885, 14 obs)	Exler (1987)
<i>Aplodinotus grunniens</i>	freshwater drum	mean = 5.5 (1.0 to 19.7, 574 obs)	mean = 4.8 (0.3 to 21.2, 459 obs)	STORET
<i>Archosargus probatocephalus</i>	sheepshead		mean = 2.41 (standard error = 0.040, 5 obs)	Exler (1987)
<i>Coregonus artedii</i>	cisco (lake herring)		mean = 1.91 (standard error = 0.149, 69 obs)	Exler (1987)
<i>Coregonus clupeaform</i>	lake whitefish		mean = 5.86 (standard error = 0.451, 68 obs)	Exler (1987)
<i>Coregonus hoyi</i>	bloater	mean = 21.1 (16 to 25.5, 52 obs)	mean = 8.3 (3.2 to 17.0, 98 obs)	STORET
<i>Dorosoma cepedianum</i>	gizzard shad	mean = 7.4 (1.3 to 18.0, 189 obs)		STORET
<i>Dorosoma petenense</i>	threadfin shad	mean = 3.0 (0.5 to 18.0, 9 obs)		STORET
<i>Gadus macrocephalus</i>	true or Pacific cod		mean = 0.63 (standard error = 0.031, 18 obs)	Exler (1987)
<i>Hiodon alosoides</i>	goldeye	mean = 3.2 (3.5 to 2.8, 74 obs)		STORET

Table C-3b. (Continued)

Species Name	Common Name	Whole Fish Lipid Content, Percent (size)	Fillet Lipid Content, Percent (size)	Reference, Comments
<i>Platygobia</i> (<i>Hybopsis</i> in database) <i>gracilis</i>	flathead chub		mean = 3.3 (0.68 to 8.14, 75 obs)	STORET
<i>Lepomis auritus</i>	redbreast sunfish	mean = 3.6 (1.3 to 8.1, 550 obs)		STORET
<i>Lepomis cyanellus</i>	green sunfish	mean = 3.2 (2.2 to 7.8, 376 obs)		STORET
<i>Lepomis gibbosus</i>	pumpkinseed	mean = 3.9 (2.2 to 7.7, 126 obs)		STORET
<i>Lepomis gibbosus</i>	pumpkinseed		mean = 0.70 (standard error = 0.071, 8 obs)	Exler (1987)
<i>Lepomis megalotis</i>	longear sunfish	mean = 2.8 (1.0 to 7.2, 536 obs)		STORET
<i>Osmerus mordax</i>	rainbow smelt	4 (16 g)		USEPA (1994)
<i>Osmerus mordax</i>	rainbow smelt		mean = 2.42 (standard error = 0.107, 52 obs)	Exler (1987)
<i>Pimephales promelas</i>	fathead minnow	19 (1 g)		Cook et al. (1991)
<i>Lepomis macrochirus</i>	bluegill sunfish	mean = 3.5 (2.4 to 4.6, 4 obs)		USEPA (1992)
<i>Lepomis macrochirus</i>	bluegill sunfish	mean = 4.4 (0.1 to 8.7, 1034 obs)		STORET
<i>Lota lota</i>	burbot		0.35 to 0.7	Owens et al. (1994)
<i>Lota lota</i>	burbot		mean = 0.2 (0.1 to 0.3, 18 obs)	STORET
<i>Lota lota</i>	burbot		mean = 0.81 (standard error = 0.059, 13 obs)	Exler (1987)
<i>Oryzias latipes</i>	medaka	8 (0.175 g)		Schmieder et al. (1992)
<i>Phoxinus erythrogaster</i>	southern redbelly dace	mean = 5.6 (2.2 to 10.0, 762 obs)		STORET

Table C-3b. (Continued)

Species Name	Common Name	Whole Fish Lipid Content, Percent (size)	Fillet Lipid Content, Percent (size)	Reference, Comments
<i>Pomoxis annularis</i>	white crappie		mean = 1.0 (0.5 to 2.0, 7 obs)	USEPA (1992)
<i>Pomoxis annularis</i>	white crappie	mean = 2.1 (0.4 to 5.8, 622 obs)	mean = 0.4 (0.08 to 2.6, 936 obs)	STORET
<i>Pomoxis nigromaculatus</i>	black crappie		mean = 1.1 (0.5 to 1.5, 3 obs)	USEPA (1992)
<i>Pomoxis nigromaculatus</i>	black crappie	mean = 2.7 (0.7 to 8.4, 457 obs)	mean = 1.4 (0.13 to 5.3, 118 obs)	STORET
<i>Prosopium williamsoni</i>	mountain whitefish	mean = 8.5 (0.5 to 13.8, 327 obs)	mean = 1.6, (0.2 to 4.1, 532 obs)	STORET
<i>Prosopium williamsoni</i>	mountain whitefish		3.4 to 11.8 (not given)	Owens et al (1994)
<i>Richardsonius balteatus</i>	reidside shiner		mean = 0.9 (0.85 to 0.96, 50 obs)	STORET
<i>Sebastes auriculatus</i>	brown rockfish		mean = 1.57 (81 obs)	Exler (1987)
<i>Sebastes marinus</i>	redfish		mean = 1.63 (standard error = 0.092, 208 obs)	Exler (1987)
<i>Semotilus atromacula</i>	creek chub	mean = 3.9 (1.0 to 5.0, 815 obs)		STORET
<i>Semotilus corporalis</i>	fallfish	mean = 1.9 (0.25 to 3.9, 100 obs)		STORET

Table C-3c. Lipid Contents of Trophic Level 4, Epibenthic Fishes

Species Name	Common Name	Whole Fish Lipid Content, Percent (size)	Fillet Lipid Content, Percent	Reference, Comments
<i>Pylodictis olivaris</i>	flathead catfish	mean = 3.1 (0.5 to 8.1, 829 obs)	mean = 3.0 (0.2 to 21.1, 1315 obs)	STORET
<i>Pylodictis olivaris</i>	flathead catfish	mean = 6.0 (1.6 to 8.7, 3 obs)	mean = 1.9 (0.6 to 3.1, 4 obs)	USEPA (1992)

Table C-3d. Lipid Contents of Trophic Level 4, Pelagic Fishes

Species Name	Common Name	Whole Fish Lipid Content, Percent (size)	Fillet Lipid Content, Percent (size)	Reference, Comments
<i>Ambloplites rupestris</i>	rock bass		mean = 1.0 (0.8 to 1.2, 3 obs)	USEPA (1992)
<i>Ambloplites rupestris</i>	rock bass	mean = 2.3 (0.6 to 4.4, 759 obs)	mean = 0.7 (0.4 to 0.98, 129 obs)	STORET
<i>Amia calva</i>	bowfin		mean = 0.5 (0.04 to 1.4, 230 obs)	STORET
<i>Centropristis striata</i>	black sea bass		mean = 2.00 (standard error = 0.221, 40 obs)	Exler (1987)
<i>Esox lucius</i>	northern pike		mean = 1.4 (0.6 to 2.6, 5 obs)	USEPA (1992)
<i>Esox lucius</i>	northern pike	mean = 1.9 (0.1 to 9.8, 810 obs)		STORET
<i>Esox lucius</i>	northern pike		mean = 0.69 (standard error = 0.005, 224 obs)	Exler (1987)
<i>Esox niger</i>	chain pickerel		mean = 1.3 (0.6 to 2.0, 5 obs)	USEPA (1992)
<i>Leiostomus xanthurus</i>	spot	mean = 5.2 (3.3 to 7.9, 300 obs)		STORET
<i>Leiostomus xanthurus</i>	spot		mean = 4.90 (standard error = 2.93, 10 obs)	Exler (1987)
<i>Lutjanus campechanus</i>	red snapper		1.34 (55 obs)	Exler (1987)
<i>Micropogonias undulatus</i>	Atlantic croaker		3.17 (standard error = 0.529, 8 obs)	Exler (1987)
<i>Micropterus dolomieu</i>	smallmouth bass		mean = 1.6 (0.8 to 4.4, 19 obs)	USEPA (1992)
<i>Micropterus dolomieu</i>	smallmouth bass	mean = 3.4 (0.3 to 8.8, 1166 obs)	mean = 0.6 (0.01 to 2.3, 848 obs)	STORET
<i>Micropterus punctulatus</i>	spotted bass		mean = 2.8 (0.9 to 4.5, 4 obs)	USEPA (1992)
<i>Micropterus punctulatus</i>	spotted bass	mean = 2.4 (0.6 to 4.9, 322 obs)	mean = 0.7 (0.1 to 1.8, 353 obs)	STORET

Table C-3d. (Continued)

Species Name	Common Name	Whole Fish Lipid Content, Percent (size)	Fillet Lipid Content, Percent (size)	Reference, Comments
<i>Micropterus salmoides</i>	largemouth bass		mean = 1.6 (0.4 to 7.6, 54 obs)	USEPA (1992)
<i>Micropterus salmoides</i>	largemouth bass	mean = 4.1 (0.3 to 10.6, 2924 obs)	mean = 0.7 (0.04 to 9.2, 4548 obs)	STORET
<i>Morone americana</i>	white perch	mean = 4.5 (2.6 to 7.1, 249 obs)		STORET
<i>Morone chrysops</i>	white bass		mean = 2.7 (0.7 to 4.8, 11 obs)	USEPA (1992)
<i>Morone chrysops</i>	white bass	mean = 4.6 (0.3 to 15.4, 615 obs)	mean = 3.9 (0.01 to 8.1, 847 obs)	STORET
<i>Morone saxatilis</i>	striped bass		mean = 2.33 (standard error = 0.381, 14 obs)	Exler (1987)
<i>Oncorhynchus gorbuscha</i>	pink salmon		mean = 3.45 (standard error = 0.141, 144 obs)	Exler (1987)
<i>Oncorhynchus kisutch</i>	coho salmon		mean = 2.7 (0.4 to 10.7, 383 obs)	STORET
<i>Oncorhynchus kisutch</i>	coho salmon		mean = 5.92 (standard error = 0.162, 217 obs)	Exler (1987)
<i>Oncorhynchus mykiss</i>	rainbow trout	11 (35 g)		Branson et al. (1985)
<i>Oncorhynchus mykiss</i>	rainbow trout		mean = 5.0 (4.1 to 5.6, 3 obs)	USEPA (1992)
<i>Oncorhynchus nerka</i>	sockeye salmon		mean = 8.56 (standard error = 0.392, 48 obs)	Exler (1987)
<i>Oncorhynchus tshawytscha</i>	chinook salmon	mean = 3.7 (2.4 to 5.1, 52 obs)	mean = 2.2 (0.04 to 17.7, 1957 obs)	STORET
<i>Oncorhynchus tshawytscha</i>	chinook salmon		mean = 10.44 (standard error = 1.692, 10 obs)	Exler (1987)
<i>Perca flavescens</i>	yellow perch	mean = 3.6 (1.2 to 9.1, 112 obs)	mean = 0.5 (0.1 to 4.6, 280 obs)	STORET
<i>Pomatomus saltatrix</i>	bluefish		mean = 4.27 (3 obs)	Exler (1987)

Table C-3d. (Continued)

Species Name	Common Name	Whole Fish Lipid Content, Percent (size)	Fillet Lipid Content, Percent (size)	Reference, Comments
<i>Salmo clarki</i> (<i>Onchorhynchus clarki</i>)	cutthroat trout		mean = 1.0 (0.2 to 1.7, 378 obs)	STORET
<i>Salmo gairdneri</i> (<i>Onchorhynchus mykiss</i>)	rainbow trout		mean = 3.36 (standard error = 0.256, 24 obs)	Exler (1987)
<i>Salmo salar</i>	Atlantic salmon		mean = 6.34 (standard error = 1.72, 7 obs)	Exler (1987)
<i>Salmo trutta</i>	brown trout		mean = 4.0 (1.6 to 8.1, 6 obs)	USEPA (1992)
<i>Salmo trutta</i>	brown trout	mean = 6.0 (1.5 to 8.9, 112 obs)	mean = 5.0 (0.14 to 14.8, 741 obs)	STORET
<i>Salvelinus namaycush</i> , <i>Oncorhynchus mykiss</i> , <i>Oncorhynchus</i> spp.	salmonids	11 (2410 g)		USEPA (1994a)
<i>Salvelinus malma</i>	Dolly Varden	mean = 7.1 (2.1 to 9.9, 3 obs)		USEPA (1992)
<i>Salvelinus namaycush</i>	lake trout	mean = 15.9 (12.6 to 18.3, 42 obs)	mean = 7.8 (2.5 to 20.0, 1883 obs)	STORET
<i>Scomberomorus cavall</i>	king mackerel		mean = 2.00 (standard error = 0.188, 6 obs)	Exler (1987)
<i>Scomberomorus macula</i>	Spanish mackerel		mean = 6.30 (standard error=3.810, 3 obs)	Exler (1987)
<i>Stizostedion canadense</i>	sauger	mean = 6.0 (0.8 to 16.3, 139 obs)	mean = 1.7 (0.3 to 10.0, 195 obs)	STORET
<i>Stizostedion vitreum</i>	walleye		0.6 to 0.7	Owens et al. (1994)
<i>Stizostedion vitreum</i>	walleye	mean = 6.2 (0.3 to 15, 1089 obs)	mean = 1.3 (0.3 to 6.0, 440 obs)	STORET
<i>Stizostedion vitreum</i>	walleye		mean = 1.22 (standard error = 0.162, 14 obs)	Exler (1987)
<i>Stizostedion vitreum</i>	walleye		mean = 1.6 (0.7 to 2.6, 13 obs)	USEPA (1992)

Analysis of Lipids Data

Lipids data were analyzed for comparison with the screening value selected for the NSI evaluation by computing averages. Eight averages of data for fishes of the following categories for data in STORET (Table C-4a) and the NSCRF (Table C-4b) were computed (and labeled A-H):

- A. Trophic levels 3 and 4, whole body
- B. Trophic levels 3 and 4, whole body, excluding migratory and saltwater fishes
- C. Trophic level 4, pelagic, fillet
- D. Trophic level 4, pelagic, fillet, excluding migratory and saltwater fishes
- E. Resident, freshwater, demersal fishes, whole body
- F. Resident, freshwater, pelagic fishes, whole body
- G. Resident, freshwater, demersal fishes, fillet
- H. Resident, freshwater, pelagic fishes, fillet.

Data for fillets and whole fish were evaluated separately. All analyses except "A" were of fishes in the NSI exclusively. Summary statistics reported include the mean, standard error, range, and number of observations. The matrices in Tables C-4a and C-4b indicate the categories of fishes averaged. The average of edible portions from USDA data was 4.1 percent lipid.

The mean fillet percent lipid content for various groups of fish species in the STORET database ranged from 0.753 to 4.49 percent; in the NSCRF, mean fillet values ranged from 1.6 to 4.9 percent. The mean whole-body percent lipid content for various groups of fish species in the STORET database ranged from 3.757 to 6.33 percent; in the NSCRF, mean whole-body values ranged from 4.6 to 8.8 percent.

Table C-4a. Lipid Analysis - STORET

Analysis	Matrix of Fishes Included in Average										Lipid Content, %			
	Trophic Level		Position in Water Column			Mobility		Habitat		Tissue/Organ	Mean	Standard Error	Number of Observations	Range
	3	4	Demersal	Pelagic	Resident	Migratory	Freshwater	Saltwater						
A	•	•	•	•	•	•	•	•	•	5.97		113,978	0.1-26.7	
B	•	•	•	•	•	•	•	•	•	5.97	0.010	110,998	0.1-26.7	
C	•	•	•	•	•	•	•	•	•	2.5		13,293	0.01-20	
D	•	•	•	•	•	•	•	•	•	0.753	0.010	6793	0.01-10	
E	•	•	•	•	•	•	•	•	•	6.33	0.011	91867	0.22-26.7	
F	•	•	•	•	•	•	•	•	•	3.757	0.020	13025	0.10-16.3	
G	•	•	•	•	•	•	•	•	•	4.49	0.018	42687	0.02-24	
H	•	•	•	•	•	•	•	•	•	1.06	0.021	9378	0.01-21.07	

Table C-4b. Lipid Analysis - NSCRF

Analysis	Matrix of Fishes Included in Average										Lipid Content, %				
	Trophic Level		Position in Water Column			Mobility			Habitat		Tissue/Organ	Mean	Standard Error	Number of Observations	Range
	3	4	Demersal	Pelagic	Resident	Migratory	Freshwater	Saltwater							
A	•	•	•	•	•	•	•	•	•	•	8.5		249	0.5-31.9	
B	•	•	•	•	•	•	•	•	•	•	8.6	0.328	246	0.5-31.9	
C	•	•	•	•	•	•	•	•	•	•	1.9		122	0.4-8.1	
D	•	•	•	•	•	•	•	•	•	•	1.6	0.116	103	0.4-7.6	
E	•	•	•	•	•	•	•	•	•	•	8.8	0.338	233	0.5-31.9	
F	•	•	•	•	•	•	•	•	•	•	4.6	1.02	7	1.6-8.7	
G	•	•	•	•	•	•	•	•	•	•	4.9	0.697	34	0.5-19.6	
H	•	•	•	•	•	•	•	•	•	•	1.6	0.106	117	0.4-7.6	

Data for filets and whole fish were evaluated separately. All analyses except "A" were of fishes in the NSF exclusively. Summary statistics reported include the mean, standard error, range, and number of observations. The matrices in Tables C-4a and C-4b indicate the categories of fishes averaged. The average of edible portions from USDA data was 4.1 percent lipid.

The mean filet percent lipid content for various groups of fish species in the STORET database ranged from 0.733 to 4.49 percent; in the NSCRF, mean filet values ranged from 1.6 to 4.9 percent. The mean whole-body percent lipid content for various groups of fish species in the STORET database ranged from 3.757 to 6.33 percent; in the NSCRF, mean whole-body values ranged from 4.6 to 8.8 percent.

References

- Branson, D.R., I.T. Takahashi, W.M. Parker, and G.E. Blau. 1985. Bioconcentration of 2, 3, 7, 8-tetrachlorodibenzo-p-dioxin in rainbow trout. *Environ. Toxicol. Chem.* 4:799-788.
- Cook, P.M. 1995. Pelagic BSAFs for NSI methodology. Memorandum from P.M. Cook, ERL, Duluth, to C. Fox, USEPA Office of Water, March 29, 1995.
- Cook, P.M., G.T. Ankley, R.J. Erickson, B.C. Butterworth, S.W. Kohlbry, P. Marquis, and H. Corcoran. 1994. *The biota-sediment accumulation factor (BSAF): Evaluation and application to assessment of organic chemical bioaccumulation in the Great Lakes*. In preparation. (cited in: USEPA, 1994a)
- Dickey, L.E. 1990. *Composition of foods, raw, processed, prepared—1990 supplement*. Agriculture Handbook 8, 1990 Supplement. U.S. Department of Agriculture, Human Nutrition Information Service, Washington, DC.
- Esser, H.O. 1986. A review of the correlation between physicochemical properties and bioaccumulation. *Pestic. Sci.* 17:265-276. (as cited by Randall et al., 1991).
- Exler, J. 1987. *Composition of foods: Finfish and shellfish products*. Agriculture Handbook No. 8-15. U.S. Department of Agriculture, Human Nutrition and Information Service, Washington, DC.
- Flint, R.W. 1986. Hypothesized carbon flow through the deep water Lake Ontario food web. *J. Great Lakes Res.* 12:344-354.
- Hansen. 1995. Assessment tools that can be used for the National Sediment Inventory. Memorandum from D.J. Hansen, ERL, Narragansett, to C. Fox, USEPA Office of Water, February 28, 1995.
- Karickhoff, S.W., D.S. Brown, and T.A. Scott. 1979. Sorption of hydrophobic pollutants on natural sediments. *Water Res.* 13: 241-248.
- Kuehl, D.W., P.M. Cook, A.R. Batterman, D.B. Lothenbach, and B.C. Butterworth. 1987. Bioavailability of polychlorinated dibenzo-p-dioxins and dibenzofurans from contaminated Wisconsin River sediment to carp. *Chemosphere* 18:1997-2014.
- Oliver, B.G., and A.J. Niimi. 1988. Trophodynamic analysis of polychlorinated biphenyl congeners and other chlorinated hydrocarbons in the Lake Ontario ecosystem. *Environ. Sci. Technol.* 22:388-397.
- Owens, J.W., S.M. Swanson, and D.A. Birkholz. 1994. Bioaccumulation of 2, 3, 7, 8-tetrachlorodibenzo-p-dioxin, 2, 3, 7, 8-tetrachlorodibenzofuran and extractable organic chlorine at a bleached kraft mill site in a northern Canadian river system. *Environ. Toxicol. Chem.* 13:343-354
- Randall, R.C., H. Lee II, R.J. Ozretich, J.L. Lake, and R.J. Pruell. 1991. Evaluation of selected lipid methods for normalizing pollutant bioaccumulation. *Environ. Toxicol. Chem.* 10:1431-1436.
- Tracey, G.A. and D.J. Hansen. 1996. Use of biota-sediment accumulation factors to assess similarity of nonionic organic chemical exposure to benthically-coupled organisms of differing trophic mode. *Arch, Environ. Contam. Toxicol.* 30:467-475.
- Schneider, P., D. Lothenbach, R. Johnson, R. Erickson, and J. Tietge. 1992. Uptake and elimination kinetics of ³H-TCDD in medaka. *Toxicologist* 12:138.
- Servos, M.R., S.Y. Huestis, D.M. Whittle, G. J. Van Der Kraak, and K.R. Munkittrick. 1994. Survey of receiving-water environmental impacts associated with discharges from pulp mills. 3. Polychlorinated dioxins and furans in muscle and liver of white sucker (*Catostomus commersoni*). *Environ. Toxicol. Chem.* 13:1103-1115.

USEPA. 1990. *Lake Ontario TCDD bioaccumulation study—Final report*. U.S. Environmental Protection Agency, Region 2, New York, NY.

USEPA. 1992. *National study of chemical residues in fish*. 2 vols. EPA 823-R-92-008a,b. U.S. Environmental Protection Agency, Office of Science and Technology, Washington, DC.

USEPA. 1994a. *Great Lakes Water Quality Initiative technical support document for the procedure to determine bioaccumulation factors—July 1994*. EPA-822-R-94-002. U.S. Environmental Protection Agency, Office of Water, Office of Science and Technology, Washington, DC.

USEPA, 1994b. *Health effects assessment summary tables FY 1994. Supplement number 2*. EPA/540/R-94/114, NTIS PB94-921102. U.S. Environmental Protection Agency, Office of Solid Waste and Emergency Response, Washington, DC. November.

USEPA, 1995. *Integrated Risk Information System (IRIS)*. Online. U.S. Environmental Protection Agency, Office of Health and Environmental Assessment, Environmental Criteria and Assessment Office, Cincinnati, OH.

Appendix D

Screening Values for Chemicals Evaluated

Sediment Concentrations

Table D-1 presents the screening values used in the evaluation of NSI sediment chemistry data. Values listed in this table are in parts per million (ppm) except for the values for EPA draft sediment quality criteria (SQC_{oc}) and sediment quality advisory levels ($SQAL_{oc}$), which are in micrograms per gram ($\mu\text{g/g}$) organic carbon. These values were multiplied by the organic carbon content (f_{oc}) of the sediment sample, when known, or the default value if unknown ($f_{oc} = 0.01$). SQALs used in this analysis were calculated specifically for use in the screening analysis of NSI data. Effects range-low (ERL) and effects range-median (ERM) values were taken from Long et al. (1995). Apparent effects threshold-low (AET-L) and apparent effects threshold-high (AET-H) values listed are values that have been normalized to dry weight. AET-Ls and AET-Hs were taken from Barrick et al. (1988). Threshold effects levels (TELs) and probable effects levels (PELs) were taken from FDEP (1994).

Fish Tissue Concentrations

Fish tissue concentrations are presented in the right columns of Table D-1. EPA risk levels were calculated for both a human health cancer risk of 10^{-5} and a noncancer hazard quotient of 1 (USEPA, 1995a, b). Other available EPA sources were consulted as necessary for risk-based concentrations to be used in a screening analysis, including the Environmental Criteria and Assessment Office (as cited in USEPA, 1995c). FDA guidance/action/tolerance levels were obtained from the FDA Office of Seafood (DHHS, 1994; 40 CFR 180.213a and 180.142; USFDA, 1993a, b, c, d, e).

Biota-Sediment Accumulation Factors

The final column in Table D-1 presents the biota-sediment accumulation factors (BSAFs) used in the analysis. The BSAFs were adopted for use in the theoretical bioaccumulation potential (TBP) calculations that represent potential concentrations that might occur in tissues of fish exposed to contaminated sediments. The methodology used in deriving BSAFs and other parameters used in the TBP calculations are described in Appendix C of this document.

Methodology for Combining Chemical Data Using a Risk-Based Approach

Several screening values, as provided in the original source documents, refer to groups of chemicals. The majority of the data included in the NSI exist as specific chemicals. To perform a screening analysis that accommodates the way the data exist in the NSI and provides a reasonably conservative risk-based approach, chemical data were combined in particular cases.

Two of the chemical groups affected by this approach are polychlorinated biphenyls (PCBs) and dioxin compounds. The data for PCBs in the NSI occur in three ways: (1) total PCBs, (2) PCB congeners, and (3) PCB aroclors. The data for the PCB congeners were summarized (excluding as appropriate the lower chlorinated homologs that may be present as laboratory artifacts) to provide a total PCB value where one was not provided by the original database. This summarization enabled comparisons to the screening values available for total PCBs. Aroclor-spe-

Table D-1. Screening Values for Chemicals Evaluated

GUIDELINE VALUES INTENDED ONLY FOR SCREENING-LEVEL HAZARD COMPARISON AMONG CHEMICALS
May Be Over- or Under-protective of Exposure at a Given Location Depending on Site-Specific Conditions

CAS Number	Chemical Name	Code	Sediment Concentration							Fish Tissue Concentration (ppm)				BSAF (unitless)
			SOC ₁₀ (µg/g _w)	ER-L (ppm)	ER-M (ppm)	AET-L (ppm)	AET-H (ppm)	SOAL ₁₀ (µg/g _w)	TEL (ppm)	PZL (ppm)	Concn. = EPA Risk 10 ⁻⁴	EPA Noncancer Hazard Quotient = 1	FDA Guidance/Action/Tolerance Level	
83329	Acenaphthene	1	130	.016	.5	.5 ^a	2 ^a	130	0.00571	0.0889	650			0.29 ^b
208968	Acenaphthylene	1		.044	.64	1.3 ^{ab}	1.3 ^{ab}		0.00387	0.128				
67641	Acetone	1									1100			1.0
98862	Acetophenone	1									1100			
107028	Acrobin	1									220			
107131	Acrylonitrile	1									11	0.2		1.0
15972608	Alcohol/Laso	1										1.3		110
116063	Alkylatyl/tenk											11		
309002	Altrin	1,3									0.0663	0.32	0.3	1.80 ^b
62533	Aniline										19			
120127	Antracene	1		.0853	1.1	.96 ^c	13 ^a		0.0469	0.245	3200			0.29 ^b
99999933	Anthracene & Phenanthrene	1	180	.0853	1.1	.96 ^c	6.9 ^a	180	0.0469	0.245	3200			0.29 ^b
7440360	Antimony						150 ^b	200 ^a			4.3			
7440382	Arsenic	2		8.2	70	57 ^b	700 ^a		7.24	41.6	0.062	3.2	68	
1912249	Atrazine										0.49	380		
7440393	Barium											750		
92875	Benzidine										0.00047	32		
71432	Benzene	1,6						5.7			3.7			1.0
56553	Benzo(a)anthracene	1		.261	1.6	1.6 ^c	5.1 ^{ab}		0.0748	0.693	0.15			0.29 ^b
99999955	Benzo(b)anthracene/Chrysene	1		.261	1.6	1.6 ^c	5.1 ^{ab}		0.0748	0.693	0.15			0.29 ^b
50228	Benzo(b)pyrene	1		.43	1.6	1.6 ^c	3.6 ^c		0.0888	0.763	0.015			0.29 ^b
205992	Benzo(k)fluoranthene	1				3.6 ^c	9.9 ^b				0.15			0.29 ^b
191242	Benzo(ghi)perylene	1					.72 ^a	2.6 ^c						
207089	Benzo(k)fluoranthene	1					3.6 ^c	9.9 ^b			1.5			0.29 ^b
65850	Benzoic acid						.65 ^{ab}	.76 ^c				43000		
98077	Benzotrichloride	1									0.0683			

Table D-1. (Continued)

CAS Number	Chemical Name	Code	Sediment Concentration										Fish Tissue Concentration (ppm)				
			SQC _{sc} (µg/g _w)	ER-L (ppm)	ER-M (ppm)	AET-L (ppm)	AET-H (ppm)	SQAL _{sc} (µg/g _w)	TEL (ppm)	FEL (ppm)	Concen- = EPA Risk 10 ⁶	EPA Noncarci- nogenic Hazard Quotient = 1	FDA Guidance/ Action/ Tolerance Level	BSAF (unitless)			
100516	Benzyl alcohol					.073 ^b	.87 ^{ab}								3200		
100447	Benzyl chloride	1												0.63			
7440417	Beryllium													.025	54		
319846	BHC, alpha-	1,3											0.00032	0.00099		0.3	1.80 ^b
319837	BHC, beta-	1,3											0.00032	0.00099		0.3	1.80 ^b
319868	BHC, delta-	1,3,6								13			0.00032	0.00099		0.3	1.80 ^b
58899	BHC, gamma- (Lindane)	1,3,6								0.37			0.00032	0.00099		0.3	1.80 ^b
608731	BHC, technical grade	1,3								0.37			0.00032	0.00099		0.3	1.80 ^b
92524	Biphenyl	1,6								110					540		0.29 ^b
111444	Bi(2-chloroethyl)ether	1												0.098			
108601	Bi(2-chloroisopropyl)ether	1												1.5	430		
117817	Bi(2-ethylhexyl)phthalate	1,6				1.3 ^b	1.9 ^c						0.182	2.65	220		1.0
542881	Bi(chloromethyl)ether													0.00049			
7440428	Boron														970		
75274	Bromochloromethane	1												1.7	220		
74839	Bromomethane	1													15		
101553	Bromophenyl phenyl ether, 4-	1,6								130					620		1.0
1689845	Bromoxynil														220		
85687	Butyl benzyl phthalate	1,6				.9 ^b	.9 ^{ab}			1100					2200		1.0
7440439	Cadmium	2		1.2	9.6	5.1 ^b	9.6 ^c					0.676	4.21		5.4	3	
6252	Carbaryl/Sevin														1100		
1563662	Carbofuran/finradan														54		
75150	Carbon disulfide														1100		
133904	Chloramben														160		
57749	Chlordane	1,3										0.00226	0.00479		0.65	0.3	4.77 ^c
5103719	Chlordane, alpha(cis)-	1,3										0.00226	0.00479		0.65	0.3	4.77 ^c

Table D-1. (Continued)

GUIDELINE VALUES INTENDED ONLY FOR SCREENING-LEVEL HAZARD COMPARISON AMONG CHEMICALS May Be Over- or Under-protective of Sediment at a Given Location Depending on Site-Specific Conditions																
CAS Number	Chemical Name	Code	Sediment Concentration						Fish Tissue Concentration (ppm)							
			SQC _{sc} (µg/g _{sc})	ER-L (ppm)	ER-M (ppm)	AET-L (ppm)	AET-H (ppm)	SOAL _{sc} (µg/g _{sc})	TEL (ppm)	FEL (ppm)	Concen- = EPA Risk 10 ⁻⁶	EPA Noncancer- Hazard Quotient = 1	FDA Guidance/ Action/ Tolerance Level	BSAF (unitless)		
5103742	Chlordane, beta(trans)-	1,3									0.00226	0.00479	0.083	0.65	0.3	2 ^a
556347	Chlordane, gamma(trans)-	1,3									0.00226	0.00479	0.083	0.65	0.3	2,22 ^a
99999247	Chlordane-Nonachlor(cis)-	1,3									0.00226	0.00479	0.083	0.65	0.3	4,77 ^a
99999248	Chlordane-Nonachlor(trans)-	1,3									0.00226	0.00479	0.083	0.65	0.3	4,77 ^a
108907	Chlorobenzene	1,6								82				220		1.0
510156	Chlorobenzilate												0.40	220		
75003	Chloroethane	1												4300		
75014	Chloroethane	1											0.057			
110758	Chloroethylmethyl ether, 2-	1														
74873	Chloroethane	1											8.3			
91587	Chloronaphthalene, 2-	1													860	
95578	Chlorophenol, 2-														54	
2921882	Chlorpyrifos/Diisobun	1													32	1,80 ^b
7440473	Chromium	2	81	370	260 ^b	270 ^a	270 ^a	270 ^a	270 ^a	52.3	160	15	54	11		
218019	Chrysene	1	.384	2.8	2.8 ^a	9.2 ^{ab}	9.2 ^{ab}	9.2 ^{ab}	9.2 ^{ab}	0.108	0.846	15	400			0,29 ^b
7440508	Copper		34	270	390 ^a	1300 ^a	1300 ^a	1300 ^a	1300 ^a	18.7	108		540			
108394	Cresol, m-				.63 ^{ac}	.72 ^b	.72 ^b	.72 ^b	.72 ^b				540			
95487	Cresol, o-				.63 ^{ac}	.72 ^b	.72 ^b	.72 ^b	.72 ^b				540			
106445	Cresol, p-				.67 ^{ac}	3.6 ^a	3.6 ^a	3.6 ^a	3.6 ^a				54			
131973	Cresols				.63 ^{ac}	.72 ^b	.72 ^b	.72 ^b	.72 ^b				54			
98828	Cumene	1											430			
21725462	Cyanazine											0.13	22			
57125	Cyanide												220			
1861321	DCPA/Dacthal	1											110			1,80 ^b
53190	DDE, o,p'-	1,3	.00158	.027	.016 ^c	.043 ^a	.043 ^a	.043 ^a	.043 ^a		0.00122	0.00781	0.45	5		0,28 ^a
72548	DDD, p, p'-	1,3	.00158	.027	.016 ^c	.043 ^a	.043 ^a	.043 ^a	.043 ^a		0.00122	0.00781	0.45	5		0,28 ^a

Table D-1. (Continued)

CAS Number	Chemical Name	Code	Sediment Concentration										Fish Tissue Concentration (ppm)				
			SOC ₅₀ (µg/g _c)	ER-L (ppm)	ER-M (ppm)	AET-L (ppm)	AET-H (ppm)	SQAL ₅₀ (µg/g _c)	TEL (ppm)	FEL (ppm)	Concn. = EPA Risk 10 ⁻⁵	EPA Noncancer- Hazard Quotient = 1	FDA Guidance/ Action/ Tolerance Level	BSAF (unitless)			
3424826	DDE, o,p'	1,3		.0022	.027	.009 ^b	.015 ^a		0.00207	0.374	0.32	5	7.7 ^a				
72559	DDT, p, p'	1,3		.0022	.027	.009 ^b	.015 ^a		0.00207	0.374	0.32	5	7.7 ^a				
789026	DDT, o,p'	1,3		.00158	.027	.034 ^b	.034 ^b		0.00119	0.00477	0.32	5.4	1.67 ^a				
50293	DDT, p, p'	1,3		.00158	.027	.034 ^b	.034 ^b		0.00119	0.00477	0.32	5.4	1.67 ^a				
999993000	DDT (Total)	1,3		.00158	.0461	.009 ^b	.015 ^a		0.00389	0.0517	0.32	5.4	7.7 ^a				
1163195	Decachlorobiphenyl oxide	1									110						
84742	Di-n-butyl phthalate	1,6				1.4 ^{ac}	1.4 ^{ac}	1100			1100		1.0				
117840	Di-n-octyl phthalate	1				6.2 ^b	6.2 ^b				220		1.0				
333415	Diazinon/Spectracide	1,6						.019			9.7		1.80 ^b				
53703	Dibenz(a,h)anthracene	1		.0634	.26	.23 ^b	.97 ^b		0.00622	0.135	0.015		0.29 ^b				
132649	Dibenzofuran	1,6				.54 ^e	1.7 ^a	200			43		1.0				
96128	Dibromo-3-chloropropane,	1									0.077						
124481	Dibromochloromethane	1									1.3	220	1.0				
1918009	Dicamba										320						
95501	Dichlorobenzene, 1,2-	1,6				0.05 ^{ab}	0.05 ^{ab}	34			970		1.0				
541731	Dichlorobenzene, 1,3-	1,6						170			960		1.0				
106467	Dichlorobenzene, 1,4-	1,6				.11 ^b	.12 ^{ac}	35			4.5		1.0				
25321226	Dichlorobenzene	1				0.05 ^{ab}	0.05 ^{ab}	34			4.5	960	1.0				
91941	Dichlorobenzidine, 3,3'										0.24						
75718	Dichlorodifluoromethane	1									2200						
75343	Dichloroethane 1,1-	1									1100		1.0				
107062	Dichloroethane 1,2-	1									1.2		1.0				
75354	Dichloroethene, 1,1-	1									0.18	97					
156605	Dichloroethene, trans-1,2-	1									220		1.0				
156592	Dichloroethylene, cis-1,2-	1									110						
75092	Dichloromethane	1									14	650	1.0				

Table D-1. (Continued)

GUIDELINE VALUES INTENDED ONLY FOR SCREENING-LEVEL HAZARD COMPARISON AMONG CHEMICALS May Be Over- or Underprotective of Sediment at a Given Location Depending on Site-Specific Conditions															
CAS Number	Chemical Name	Code	Sediment Concentration						Fish Tissue Concentration (ppm)						
			SQC ₁₀ (µg/g _w)	ER-L (ppm)	ER-M (ppm)	AET-L (ppm)	AET-H (ppm)	SQAL ₁₀ (µg/g _w)	TEL (ppm)	FEL (ppm)	Concn. = EPA Risk 10 ⁻⁶	EPA Noncarci- genic Hazard Quotient = 1	FDA Guidance/ Action/ Tolerance Level	BSAF (unitless)	
120832	Dichlorophenol, 2,4-												32		
94757	Dichlorophenoxyacetic acid, 2,4-	5											110		1
94826	Dichlorophenoxybutanolic acid, 2,4-														
78875	Dichloropropane, 1,2-	1										1.6			1.0
542756	Dichloropropane, 1,3-	1										0.62			
62737	Dichlorvos	1										0.37		5.4	
115322	Dicobaltchloride											0.24			
60571	Dextrin	1,5,6	11							11	7.15E-4	0.0043	.54	.3	1.80 ^b
84662	Diethyl phthalate	1,6				0.2 ^b							8600		1.0
119904	Dimethylbenzidine, 3,3'-												7.7		
131113	Dimethyl phthalate	1				0.16 ^c							110000		1.0
105679	Dimethylphenoxy, 2,4-					.029 ^c							220		
528290	Dinitrobenzene, 1,2-												4.3		
99630	Dinitrobenzene, 1,3-												1.1		
100254	Dinitrobenzene, 1,4												4.3		
51285	Dinitrophenol, 2,4-												22		
121142	Dinitrotoluene, 2,4-												22		
606202	Dinitrotoluene, 2,6-												11		
88857	Dioxobenzene, 1,2												11		
122667	Diphenylhydrazine, 1,2-											0.13			
298044	Disulfoton	1											0.43		
959988	Endosulfan, alpha-	1,6								.29			65		1.80 ^b
33213639	Endosulfan, beta-	1,6								1.4			65		1.80 ^b
115297	Endosulfan mixed isomers	1,6								.54			65		1.80 ^b
72208	Endrin	1,6	4.2							4.2			3.2		1.80 ^b
563122	Ethionchloride	1											5.4		1.80 ^b

Table D-1. (Continued)

CAS Number	Chemical Name	Code	Sediment Concentration								Fish Tissue Concentration (ppm)				BSAF (unitless)	
			SOC _{oc} (µg/g _{oc})	ER-L (ppm)	ER-M (ppm)	AET-L (ppm)	AET-H (ppm)	SQA _{oc} (µg/g _{oc})	TEL (ppm)	PEL (ppm)	Concen- = EPA Risk 10 ⁻⁵	EPA Noncancer- Hazard Quotient = 1	FDA Guidance/ Action/ Tolerance Level			
141786	Ethyl acetate	1												9700		
100414	Ethylbenzene	1,6				.01 ^b	.037 ^b			480				1100		1.0
106934	Ethylene dibromide	1											.0013			
206440	Fluoranthene	1	620	.6	5.1	2.5 ^a	30 ^a			620	0.113	1.494		430		0.29 ^b
86737	Fluorene	1,6		.019	.54	.54 ^a	3.6 ^a			54	0.0212	0.144		430		0.29 ^b
944229	Fonofos	1												22		
76448	Hepachlor	1,3											0.024	5.4	.3	1.80 ^b
1024573	Heptachlor epoxide	1,3											0.012	0.14	.3	1.80 ^b
118741	Hexachlorobenzene	1				.022 ^b	.23 ^b						0.067	8.6		0.09 ^a
87683	Hexachlorobutadiene	1				.011 ^b	.27 ^b						1.4	2.2		1.0
77474	Hexachlorocyclopentadiene	1												75		
67721	Hexachlorocyclohexane	1,6								100			7.7	11		1.0
51235042	Hexachloro	1												360		
123319	Hydroquinone													430		
193395	Indene(1,2,3-cd)pyrene	1				.69 ^a	2.6 ^a						0.15			0.29 ^b
78591	Isophorone	1											110	2200		1.0
33820530	Isopropalin													160		
7439921	Lead	2		46.7	218	450 ^b	660 ^{oo}				30.2	112			1.3	
121755	Mahabon	1,6								.067				220		1.80 ^b
108316	Maleic anhydride													1100		
7439965	Manganese													54		
7439976	Mercury			.15	.71	.59 ^a	2.1 ^{ab}				0.13	0.696		1.1	1	
72435	Methoxyethyl	1,6												54		1.80 ^b
78933	Methyl ethyl ketone	1												6500		1.0
108101	Methyl isobutyl ketone	1												860		
22967926	Methyl mercapt	3												1.1	1	

Table D-1. (Continued)

CAS Number	Chemical Name	Code	Sediment Concentration										Fish Tissue Concentration (ppm)				
			SOCL _w (µg/kg)	ER-L (ppm)	ER-M (ppm)	AET-L (ppm)	AET-H (ppm)	SOAL _w (µg/kg)	TEL (ppm)	FEL (ppm)	Concen. = EPA Risk 10 ⁻⁴	EPA Noncancer Hazard Quotient = 1	FDA Guidance/ Action/ Tolerance Level	BSAF (unitless)			
91576	Methylphthalates, 2-	1		.07	.67	.67 ^a	1.9 ^a					0.0202	0.201				
21087649	Merbutzin													270			
2385855	Mirex/Decchlorane	1,3											0.060	2.2	0.1	1.31 ^a	
7439987	Molybdenum													54			
91203	Naphthalene	1,6	.16	2.1	2.1	2.1 ^a	2.7 ^b			47	0.0346	0.391		430			0.29 ^b
91598	Naphthalene, 2-																
7440020	Nickel	2	20.9	51.6							15.9	42.8		220	70		
98953	Nitrobenzene													5.4			
100027	Nitrophenol, 4													670			
924163	Nitrosodi-n-butylamine, N-												0.020				
621647	Nitrosodi-n-propylamine, N-												0.015				
55185	Nitrosodimethylamine, N-												0.0021				
86306	Nitrosodiphenylamine, N-						.028 ^b	.13 ^c					22				
999999484	PAHs (high molecular weight)		1.7	9.6	17 ^{abc}	17 ^{abc}	69 ^{abc}				0.655	6.676					
999999502	PAHs (low molecular weight)		.552	3.16	5.2 ^{ab}	5.2 ^{ab}	24 ^{ab}				0.312	1.442					
56382	Parathion ethyl													65			
12674112	PCB (Aroclor-1016)	1,4	.0227	.180	1.0 ^b	1.0 ^b	3.1 ^a				0.0216	0.189	0.014	0.75	2	1.85 ^a	
11104282	PCB (Aroclor-1221)	1,4	.0227	.180	1.0 ^b	1.0 ^b	3.1 ^a				0.0216	0.189	0.014	0.22	2	1.85 ^a	
11141165	PCB (Aroclor-1232)	1,4	.0227	.180	1.0 ^b	1.0 ^b	3.1 ^a				0.0216	0.189	0.014	0.22	2	1.85 ^a	
53469219	PCB (Aroclor-1242)	1,4	.0227	.180	1.0 ^b	1.0 ^b	3.1 ^a				0.0216	0.189	0.014	0.22	2	1.85 ^a	
12672296	PCB (Aroclor-1248)	1,4	.0227	.180	1.0 ^b	1.0 ^b	3.1 ^a				0.0216	0.189	0.014	0.22	2	1.85 ^a	
11097691	PCB (Aroclor-1254)	1,4	.0227	.180	1.0 ^b	1.0 ^b	3.1 ^a				0.0216	0.189	0.014	0.22	2	1.85 ^a	
11096823	PCB (Aroclor-1260)	1,4	.0227	.180	1.0 ^b	1.0 ^b	3.1 ^a				0.0216	0.189	0.014	0.22	2	1.85 ^a	
608935	Pentachlorobenzene	1,6								69				8.6			0.04 ^a
82688	Pentachloronitrobenzene/Quinizar- e												0.41	32			
87865	Pentachlorophenol						.36 ^c	.69 ^b						0.90	320		

Table D-1. (Continued)

CAS Number	Chemical Name	Code	Sediment Concentration								Fish Tissue Concentration (ppm)				
			SQC _c (µg/g _w)	ER-L (ppm)	ER-M (ppm)	AET-L (ppm)	AET-H (ppm)	SOAL _w (µg/g _w)	TEL (ppm)	FEL (ppm)	Concn. = EPA Risk 10 ⁻⁶	EPA Noncancer- Hazard Quotient = 1	FDA Guidance/ Action/ Tolerance Level	BSAF (unitless)	
85018	Picnathrene	1	180	0.240	1.5	1.5 ^a	6.9 ^a	180	0.0867	0.544					
108952	Phenol					.42 ^b	1.2 ^{ab}				6500				
298022	Phorate/PhosphorThimet	1									2.2				
85449	Phtalic anhydride										22000				
1336363	Polychlorinated biphenyls	1,4		0.0227	0.180	1.0 ^b	3.1 ^a		0.0216	0.189	0.014	0.22	2	1.85 ^a	
1610180	Prometon/Frankol										160				
7287196	Prometryn/Caparol										43				
2395085	Promazine										810				
1918167	Propachlor										140				
129000	Pyrene	1		.665	2.6	3.3 ^a	16 ^{ab}		0.153	1.398	320			0.29 ^a	
91225	Quinoline	1									0.009				
7782492	Sekunitim										54				
7440224	Silver			1	3.7	6.1 ^a	6.1 ^a		0.733	1.77	54				
122349	Sinazine	5									54	12			
7440246	Strontium										6500				
100425	Styrene	1									2200				
13071799	Terbufof/Courier	1									0.27				
886500	Terbutyn										11				
95943	Tetrachlorobenzene, 1,2,4,5-	1									3.2			1.0	
1746016	Tetrachlorodibenzo-p-dioxin, 2,3,7,8-	1									6.9E-7			0.039 ^a	
79345	Tetrachloroethane, 1,1,2,2-	1,6						160			0.54			1.0	
127184	Tetrachloroethene	1,6				.057 ^b	.14 ^a	53			2.1	110		1.0	
56235	Tetrachloroethane	1,6						120			0.83	7.5		1.0	
58902	Tetrachlorophenol, 2,3,4,6-										320				
961115	Tetrachlorophospho/Gardona/Strof	1									4.5	320			
7440315	Tin										6500				

Table D-1. (Continued)

CAS Number	Chemical Name	Code	Sediment Concentration								Fish Tissue Concentration (ppm)				BSAP (unitless)	
			SQC _w (µg/g _w)	ER-L (ppm)	ER-M (ppm)	AET-L (ppm)	AET-II (ppm)	SOAL _w (µg/g _w)	TEL (ppm)	FEL (ppm)	Concn. = EPA Risk 10 ⁴	EPA Noncancer Hazard Quotient = 1	FDA Guidance/Action/Tolerance Level			
108883	Toluene	1,6								89				2200		1.0
8001352	Toluene	1,6								10			.098			1.80*
75252	Tribromomethane (Bromoform)	1,6								65			14	220		1.0
120821	Tribromobenzene, 1,2,4-	1,6				.051*		.064*		920				110		1.0
71556	Tribromoethane, 1,1,1-	1,6								17				970		1.0
79005	Tribromoethane, 1,1,2-	1											1.9	43		1.0
79016	Tribromobenzene	1,6								210			9.8	65		1.0
75694	Tribromofluoromethane	1												3200		1.0
67663	Tribromomethane (Chloroform)	1											18	110		1.0
95954	Tribromophenol, 2,4,5-													1100		
88062	Tribromophenol, 2,4,6-															
93765	Tribromophenoxyacetic acid, 2,4,5-															
93721	Tribromophenoxypropionic acid, 2,4,5-															
1582098	Tribromophenol													14	81	
95636	Trimethylbenzene, 1,2,4-	1												5.4		
118967	Trirotobenzene												3.6	5.4		
7440622	Vanadium													75		
108054	Vinyl acetate	1												11000		
108383	Xylene, m-	1,6				.04*		.12*		2.5				22000		1.0
95476	Xylene, o-	1				.04*		.12*		2.5				22000		1.0
106423	Xylene, p-	1				.04*		.12*		2.5				22000		1.0
1330207	Xylenes	1				.04*		.12*		2.5				22000		1.0
7440666	Zinc		150	410		410*		1600*				124	271	3200		
88888881	Dioxin-toxic equivalents	1											6.9E-7			0.005*

Table D-1. (Continued)

Codes:

1. Chemical is a nonpolar organic.
2. FDA criterion is a guideline.
3. FDA criterion is an action level.
4. FDA criterion is a tolerance level, with the force of law.
5. Fish tissue action level set by USEPA, 40 CFR Part 180.
6. Preliminary SQAL_{oc} developed for this chemical is under technical review.

AET Criteria:

- ^a Sediment concentration based on amphipods.
- ^b Sediment concentration based on benthic organisms.
- ^c Sediment concentration based on oysters.

BSAF Sources:

- ^a Cook, 1995.
- ^b Hansen, 1995.

cific data were analyzed separately. In addition, the dioxin congeners were evaluated using the toxicity equivalence factor (TEF) approach (USEPA, 1989). This approach involves summarizing specific dioxin congeners based on their toxicity as compared to 2,3,7,8-tetrachlorodibenzo-p-dioxin, for which screening values are available. PCBs and dioxin represent the only cases where chemical data were actually combined for the NSI evaluation.

Because EPA typically performs risk-based screening by analyzing closely related chemicals with the same risk-based concentrations, this methodology was applied to the NSI evaluation. If no screening values were available for a certain chemical, but were available for a closely related chemical or group of chemicals, the lower or more conservative screening values of the closely related chemicals were used in analyzing the chemicals without screening values. This methodology was applied only for chemicals or chemical groups with more than 20 positive results. The following chemicals and chemical groups were affected by this methodology: BHCs, chlordanes, cresols, DDT and metabolites, dichlorobenzenes, endosulfans, methylmercury, anthracene and phenanthrene, benzo(a)anthracene/chrysene, xylenes, and PCBs (in applying screening values to aroclors with no available screening values).

Frequency of Detection

The frequency at which a given chemical or chemical group is responsible for sites in the NSI being categorized as Tier 1 or Tier 2 is often a reflection of the number of times that chemical is measured and detected in sediment samples. Thus, chemicals that are measured and detected less frequently might not often be identified as posing a potential risk to aquatic life or human health, even though the chemical is highly toxic. Table D-2 lists the number of times each chemical included in the NSI evaluation was measured and detected (i.e., a positive result) in sediment and fish tissue and the number of times each chemical was responsible for Tier 1 or Tier 2 sampling stations being classified.

Table D-2. Frequency of Detection of Chemicals in Sediment and Fish Tissue and Number of Detections Resulting in Risk (Tier 1 or Tier 2)^{a, b}

CAS Number	Chemical Name	Number of Times Measured in Sediment	Number of Positive Sediment Results	Number of Times Measured in Tissue ^c	Number of Positive Tissue Results ^c	Tier 1 Level Results	Tier 2 Level Results
83329	Acenaphthene	6126	1567	777	41	144	359
208968	Acenaphthylene	5774	1286	-	-	74	958
67641	Acetone	547	48	22	16	-	-
107028	Acrolein	-	-	464	-	-	-
107131	Acrylonitrile	1034	9	464	-	-	7
15972608	Alachlor/Lasso	-	-	976	1	-	-
309002	Aldrin	14311	658	8029	612	2	712
62533	Aniline	-	-	10	-	-	-
120127	Anthracene	5211	1798	748	63	168	728
999999933	Anthracene & Phenanthrene	260	199	4	-	82	95
7440360	Antimony	5923	2980	1275	99	-	56
7440382	Arsenic	22281	18791	5528	2113	189	8613
1912249	Atrazine	-	-	880	-	-	-
7440393	Barium	-	-	986	837	-	-
71432	Benzene	2248	136	976	90	-	16
92875	Benzidine	-	-	537	-	-	-
56553	Benzo(a)anthracene	6718	3236	820	153	241	1540
999999955	Benzo(a)anthracene/Chrysene	272	243	-	-	146	76
50328	Benzo(a)pyrene	7011	3263	831	58	317	2292
205992	Benzo(b)fluoranthene	4179	1249	717	26	-	441
191242	Benzo(ghi)perylene	6034	2016	-	-	-	259
207089	Benzo(k)fluoranthene	4192	1093	651	21	-	113
65850	Benzoic acid	1724	247	121	5	-	41
100516	Benzyl alcohol	1910	90	120	-	-	13
7440417	Beryllium	-	-	1301	81	-	39
92524	Biphenyl	1215	873	564	138	-	2
542881	Bis(chloromethyl)ether	-	-	76	-	-	-
111444	Bis(2-chloroethyl)ether	-	-	636	3	-	3
108601	Bis(2-chloroisopropyl)ether	-	-	34	1	-	-
117817	Bis(2-ethylhexyl)phthalate	4606	1998	647	91	401	1109
7440428	Boron	-	-	44	21	-	-
75274	Bromodichloromethane	-	-	560	4	-	-
74839	Bromomethane	-	-	491	3	-	-
101553	Bromophenyl phenyl ether, 4-	2698	20	656	1	-	7
85687	Butyl benzyl phthalate	4069	333	634	4	1	51
319846	BHC, alpha-	9109	219	8148	1670	11	461
319857	BHC, beta-	6761	241	3060	209	-	257
319868	BHC, deka-	4891	99	2156	65	1	94

Table D-2. (Continued)

CAS Number	Chemical Name	Number of Times Measured in Sediment	Number of Positive Sediment Results	Number of Times Measured in Tissue ^a	Number of Positive Tissue Results ^c	Tier 1 Level Results	Tier 2 Level Results
58899	BHC, gamma-Lindane	14442	999	8750	1391	101	527
608731	BHC, technical grade	169	166	115	31	3	66
7440439	Cadmium	27919	15176	6743	3321	-	7206
75150	Carbon disulfide	-	-	24	21	-	-
57749	Chlordane	12432	2170	7316	4568	116	4228
99999247	Chlordane-Nonachlor(cis)-	1476	9	4468	2101	-	268
99999248	Chlordane-Nonachlor(trans)-	1992	31	4569	2764	-	556
5103719	Chlordane, alpha(cis)-	4416	1516	6092	3659	3	1157
5103742	Chlordane, beta(trans)-	2833	443	5841	3045	3	847
5566347	Chlordane, gamma(trans)-	967	334	85	19	-	207
108907	Chlorobenzene	2111	58	819	18	-	4
510156	Chlorobenzilate	-	-	22	-	-	-
75003	Chloroethane	-	-	557	1	-	-
75014	Chloroethene	-	-	706	2	-	2
110758	Chloroethylvinyl ether, 2-	-	-	534	-	-	-
74873	Chloromethane	-	-	744	12	-	-
91587	Chloronaphthalene, 2-	-	-	655	1	-	-
95578	Chlorophenol, 2-	-	-	629	1	-	-
2921882	Chlorpyrifos/Dursban	305	5	793	143	-	-
7440473	Chromium	27504	25216	5508	3283	426	4126
218019	Chrysene	6975	3580	893	149	185	1618
7440508	Copper	27956	25452	6284	5533	-	11213
108394	Cresol, m-	988	780	-	-	-	41
95487	Cresol, o	1993	745	51	-	-	22
106445	Cresol, p-	985	84	49	3	-	31
1319773	Cresols	18	1	-	-	-	1
21725462	Cyanazine	-	-	326	-	-	-
57125	Cyanide	-	-	14	3	-	-
84742	Di-n-butyl phthalate	4651	986	637	55	9	112
117840	Di-n-octyl phthalate	4179	435	650	6	-	23
333415	Diazinon/Spectracide	3712	249	172	-	-	188
53703	Dibenzo(a,h)anthracene	7564	2431	824	16	419	1732
132649	Dibenzofuran	2564	416	126	-	25	51
124481	Dibromochloromethane	2033	18	562	1	-	-
95501	Dichlorobenzene, 1,2-	4402	107	892	2	38	23
541731	Dichlorobenzene, 1,3-	4315	132	797	2	-	22
106467	Dichlorobenzene, 1,4-	4352	268	887	3	53	41
25321226	Dichlorobenzenes	27	12	-	-	6	3
91941	Dichlorobenzidine, 3,3'-	-	-	639	1	-	-

Table D-2. (Continued)

CAS Number	Chemical Name	Number of Times Measured in Sediment	Number of Positive Sediment Results	Number of Times Measured in Tissue ^c	Number of Positive Tissue Results ^c	Tier 1 Level Results	Tier 2 Level Results
75718	Dichlorodifluoromethane	-	-	174	-	-	-
75343	Dichloroethane 1,1-	1918	19	561	-	-	-
107062	Dichloroethane 1,2-	1981	20	972	8	-	-
156605	Dichloroethene, trans-1,2-	1393	33	793	2	-	-
75354	Dichloroethene, 1,1-	-	-	973	2	-	-
75092	Dichloromethane	2177	576	532	112	-	11
120832	Dichlorophenol, 2,4-	-	-	642	1	-	-
94757	Dichlorophenoxyacetic acid, 2,4-	-	-	39	-	-	-
78875	Dichloropropane, 1,2-	2015	15	563	2	-	-
542756	Dichloropropene, 1,3-	-	-	107	-	-	-
115322	Dicofol/Kelthane	-	-	400	26	-	-
60571	Dieldrin	14702	3113	10243	5583	89	6709
84662	Diethyl phthalate	4188	367	654	2	34	48
131113	Dimethyl phthalate	4118	135	653	-	-	38
105679	Dimethylphenol, 2,4-	4541	80	640	1	-	54
51285	Dinitrophenol, 2,4-	-	-	631	-	-	-
121142	Dinitrotoluene, 2,4-	-	-	636	1	-	-
606202	Dinitrotoluene, 2,6-	-	-	636	1	-	-
122667	Diphenylhydrazine, 1,2-	-	-	509	-	-	-
298044	Disulfoton	-	-	23	-	-	-
1861321	DCPA/Dacthal	129	76	827	586	-	3
53190	DDD, o,p'-	6349	977	3397	428	73	502
72548	DDD, p, p'-	15311	4411	6252	2481	572	2574
3424826	DDE, o,p'-	5434	632	3427	401	118	222
72559	DDE, p, p'-	15961	5980	7656	5715	823	3501
999999300	DDT (Total)	3710	736	5750	4183	122	860
789026	DDT, o,p'-	6056	567	3479	368	25	268
50293	DDT, p, p'-	16028	3268	5843	1677	371	1839
115297	Endosulfan mixed isomers	2606	80	49	12	-	20
959988	Endosulfan, alpha-	5581	84	2832	53	-	45
33213659	Endosulfan, beta-	5886	260	2157	10	-	42
72208	Endrin	12694	289	8192	893	-	8
563122	Ethion/Bladen	2953	38	170	-	-	-
100414	Ethylbenzene	2543	118	807	50	1	42
206440	Fluoranthene	7562	4563	953	216	234	1074
86737	Fluorene	6652	2280	797	14	231	1141
944229	Fonofos	-	-	288	-	-	-
76448	Heptachlor	11952	673	7369	1006	-	210
1024573	Heptachlor epoxide	12829	986	7480	2896	-	1431

Table D-2. (Continued)

CAS Number	Chemical Name	Number of Times Measured in Sediment	Number of Positive Sediment Results	Number of Times Measured in Tissue ^a	Number of Positive Tissue Results ^a	Tier 1 Level Results	Tier 2 Level Results
118741	Hexachlorobenzene	10044	1445	6970	1519	-	224
87683	Hexachlorobutadiene	4198	128	1161	14	-	81
67721	Hexachloroethane	3801	4	636	-	-	1
193395	Indeno(1,2,3-cd)pyrene	5874	1913	756	20	-	559
78591	Isophorone	3400	40	635	4	-	8
33820530	Isopropain	-	-	392	15	-	-
7439921	Lead	29979	24971	6654	3008	-	8883
121755	Malathion	4041	38	500	1	-	26
108316	Maleic anhydride	-	-	2	-	-	-
7439965	Manganese	-	-	1000	971	-	5
7439976	Mercury	26142	16632	9752	8424	1951	5049
72435	Methoxychlor	9183	154	5912	63	-	33
78933	Methyl ethyl ketone	519	7	20	11	-	-
108101	Methyl isobutyl ketone	-	-	26	-	-	-
22967926	Methyl mercury	-	-	9	8	-	-
91576	Methylnaphthalene, 2-	2629	973	-	-	71	522
21087649	Metribuzin	-	-	289	-	-	-
2385855	Mirex/Decchlorane	5794	544	4800	915	-	40
7439987	Molybdenum	-	-	707	169	-	-
91203	Naphthalene	6823	2820	803	22	291	1247
7440020	Nickel	21519	18550	3120	974	-	9260
98953	Nitrobenzene	-	-	635	-	-	-
100027	Nitrophenol, 4	-	-	606	1	-	-
621647	Nitrosodi-n-propylamine, N-	-	-	645	1	-	1
86306	Nitrosodiphenylamine, N-	3730	66	661	3	-	45
999999484	PAHs (high molecular weight)	1566	885	-	-	93	383
999999502	PAHs (low molecular weight)	1604	895	-	-	112	382
56382	Parathion ethyl	-	-	499	4	-	-
608935	Pentachlorobenzene	114	54	404	30	-	4
82688	Pentachloronitrobenzene/Quintozone	-	-	390	2	-	-
87865	Pentachlorophenol	5622	195	1756	149	-	26
85018	Phenanthrene	7067	4078	-	-	335	694
108952	Phenol	4595	864	647	12	-	155
1336363	Polychlorinated biphenyls	11296	4183	10642	7379	8151	2620
1610180	Prometon/Pramitol	-	-	289	-	-	-
1918167	Propachlor	-	-	1	-	-	-
129000	Pyrene	7558	4555	952	187	482	1896
12674112	PCB (Aroclor-1016)	5098	46	3161	12	19	39
11104282	PCB (Aroclor-1221)	5627	7	3568	2	4	5

Table D-2. (Continued)

CAS Number	Chemical Name	Number of Times Measured in Sediment	Number of Positive Sediment Results	Number of Times Measured in Tissue ^c	Number of Positive Tissue Results ^c	Tier 1 Level Results	Tier 2 Level Results
11141165	PCB (Aroclor-1232)	5417	13	3195	1	4	10
53469219	PCB (Aroclor-1242)	6375	435	4446	220	355	270
12672296	PCB (Aroclor-1248)	6314	559	4464	688	916	280
11097691	PCB (Aroclor-1254)	7178	1305	5871	3343	3664	765
11096825	PCB (Aroclor-1260)	6885	890	6035	3611	3866	531
7782492	Selenium	-	-	2559	2079	-	4
7440224	Silver	11082	6256	1739	515	350	1083
122349	Simazine	-	-	289	-	-	-
7440246	Strontium	-	-	45	45	-	-
100425	Styrene	-	-	191	-	-	-
88888882	SEM est ([SEM]-[AVS])	335	335	-	-	8	161
95943	Tetrachlorobenzene, 1,2,4,5-	97	1	398	12	-	-
1746016	Tetrachlorodibenzo-p-dioxin, 2,3,7,8-	631	38	908	391	353	23
79345	Tetrachloroethane, 1,1,2,2-	1683	49	978	33	-	2
127184	Tetrachloroethene	2429	109	973	49	2	17
56235	Tetrachloromethane	2010	15	979	4	-	-
58902	Tetrachlorophenol, 2,3,4,6-	-	-	71	-	-	-
7440315	Tin	-	-	382	264	-	-
108883	Toluene	2338	325	814	116	-	28
8001352	Toxaphene	10912	75	6566	643	-	684
75252	Tribromomethane/Bromoform	2078	44	818	7	-	-
120821	Trichlorobenzene, 1,2,4-	4256	87	1082	46	6	49
71556	Trichloroethane, 1,1,1-	2083	63	815	23	-	10
79005	Trichloroethane, 1,1,2-	2035	14	879	7	-	-
79016	Trichloroethene	2494	75	975	19	-	1
75694	Trichlorofluoromethane	1096	9	288	15	-	-
67663	Trichloromethane/Chloroform	2277	76	972	37	-	-
95954	Trichlorophenol, 2,4,5-	-	-	73	-	-	-
88062	Trichlorophenol, 2,4,6-	-	-	658	-	-	-
93765	Trichlorophenoxyacetic acid, 2,4,5-	-	-	3	-	-	-
93721	Trichlorophenoxypropionic acid, 2,4,5-	-	-	36	-	-	-
1582098	Trifluralin/Triflan	-	-	925	193	-	-
7440622	Vanadium	-	-	768	465	-	-
108054	Vinyl acetate	-	-	21	-	-	-
108383	Xylene, m-	55	31	-	-	4	6
95476	Xylene, o-	61	1	-	-	-	1
106423	Xylene, p-	14	2	-	-	-	2
1330207	Xylenes	922	48	22	13	5	11
7440666	Zinc	27065	26473	4580	4553	-	5176

Table D-2. (Continued)

CAS Number	Chemical Name	Number of Times Measured in Sediment	Number of Positive Sediment Results	Number of Times Measured in Tissue ^a	Number of Positive Tissue Results ^a	Tier 1 Level Results	Tier 2 Level Results
88888881	Dioxin toxic equivalents	56	56	590	590	459	45

^aResults presented at observation level. Multiple observations may have occurred at a given station.

^bObservations recorded here correspond only to stations with available latitude/longitude coordinates.

^cFish tissue results are presented for demersal, resident, and edible species only.

References

- Barrick, R., S. Becker, L. Brown, H. Beller, and R. Pastorok. 1988. *Sediment quality values refinement: 1988 update and evaluation of Puget Sound AET. Vol. 1.* Prepared for the Puget Sound Estuary Program, Office of Puget Sound.
- Cook, P.M. 1995. Pelagic BSAFs for NSI methodology. Memorandum from P.M. Cook, ERL Duluth, to C. Fox, EPA, Office of Water, March 29, 1995.
- DHHS. 1994. *Action levels for poisonous or deleterious substances in human food and animal feed.* U.S. Food and Drug Administration, Department of Health and Human Services, Public Health Service, Washington, DC.
- FDEP. 1994. *Approach to the assessment of sediment quality in Florida coastal waters, Vol. 1. Development and evaluation of sediment quality assessment guidelines.* Prepared for Florida Department of Environmental Protection, Office of Water Policy, Tallahassee, FL, by MacDonald Environmental Sciences Ltd., Ladysmith, British Columbia.
- Hansen. 1995. Assessment tools that can be used for the National Sediment Inventory. Memorandum from D. J. Hansen, ERL, Narragansett, to C. Fox, Office of Water, February 28, 1995.
- Long, E.R., D.D. MacDonald, S.L. Smith, and F.D. Calder. 1995. Incidence of adverse biological effects within ranges of chemical concentrations in marine and estuarine sediments. *Environ. Manage.* 19(1):81-97.
- USEPA. 1989. *Interim procedures for estimating risks associated with exposures to mixtures of chlorinated dibenzo-p-dioxins and dibenzofurans (CDDs and CDFs) and 1989 update.* EPA/625/3-89/016 U.S. Environmental Protection Agency, Risk Assessment Forum, Washington, DC.
- . 1995a. *Integrated Risk Information System (IRIS).* Online. U.S. Environmental Protection Agency, Office of Health and Environmental Assessment, Environmental Criteria and Assessment Office, Cincinnati, OH.
- . 1995b. *Health effects assessment summary tables FY 1995.* EPA/540/R-95/036. U.S. Environmental Protection Agency, Office of Solid Waste and Emergency Response, Washington, DC.
- . 1995c. Risk-based concentration table, January-June 1995. USEPA Region 3.
- USFDA. 1993a. *Guidance document for arsenic in shellfish.* U.S. Food and Drug Administration, Center for Food Safety and Applied Nutrition, Washington, DC.
- . 1993b. *Guidance document for cadmium in shellfish.* U.S. Food and Drug Administration, Center for Food Safety and Applied Nutrition, Washington, DC.
- . 1993c. *Guidance document for chromium in shellfish.* U.S. Food and Drug Administration, Center for Food Safety and Applied Nutrition, Washington, DC.
- . 1993d. *Guidance document for lead in shellfish.* U. S. Food and Drug Administration, Center for Food Safety and Applied Nutrition, Washington, DC.
- . 1993e. *Guidance document for mercury in shellfish.* U.S. Food and Drug Administration, Center for Food Safety and Applied Nutrition, Washington, DC.

Appendix E

Cancer Slope Factors and Noncancer Reference Doses Used to Develop EPA Risk Levels

Table E-1 presents the cancer slope factors and noncancer reference doses that were used to calculate the EPA risk levels and hazard quotients used in the analysis. The calculations for the EPA risk levels and hazard quotients used in the analysis appear in Appendix B. The slope factors and reference doses were obtained from the following sources:

- *Health Effects Assessment Summary Tables FY 1995*. EPA/540/R-95/036. U.S. Environmental Protection Agency, Office of Solid Waste and Emergency Response, Washington, DC.
- *Integrated Risk Information System (IRIS)*. Online. U.S. Environmental Protection Agency, Office of Health and Environmental Assessment, Environmental Criteria and Assessment Office, Cincinnati, OH.
- *Risk-Based Concentration Table, January-June 1995*. U.S. Environmental Protection Agency, Region 3, Philadelphia, PA.

Table E-1. Cancer Slope Factors and Noncancer Reference Doses Used to Develop EPA Risk Levels

CAS Number	Chemical Names	Cancer Slope Factor (mg/kg/d) ⁻¹ (Followed by source; see footnotes)	Noncancer Reference Dose (mg/kg/d) (Followed by source; see footnotes)	Surrogate Chemical Used (if necessary)
83329	Acenaphthene		6.00E-2 ⁱ	
67641	Acetone		1.00E-1 ⁱ	
98862	Acetophenone		1.00E-1 ⁱ	
107028	Acrolein		2.00E-2 ^h	
107131	Acrylonitrile	5.40E-1 ⁱ	1.00E-3 ^h	
15972608	Alachlor/Lasso	8.00E-2 ^h	1.00E-2 ⁱ	
116063	Aldicarb/Temik		1.00E-3 ⁱ	
309002	Aldrin	1.70E+1 ⁱ	3.00E-5 ⁱ	
62533	Aniline	5.70E-3 ⁱ		
120127	Anthracene		3.00E-1 ⁱ	
99999933	Anthracene & Phenanthrene		3.00E-1	anthracene
7440360	Antimony		4.00E-4 ⁱ	
7440382	Arsenic	1.75E+0 ⁱ	3.00E-4 ⁱ	
1912249	Atrazine	2.22E-1 ^h	3.50E-2 ⁱ	
7440393	Barium		7.00E-2 ⁱ	
92875	Benzidine	2.30E+2 ⁱ	3.00E-3 ⁱ	
71432	Benzene	2.90E-2 ⁱ		
56553	Benzo(a)anthracene	7.30E-1 ^e		
99999955	Benzo(a)anthracene/Chrysene	7.30E-1		benzo(a)anthracene
50328	Benzo(a)pyrene	7.30E+0 ⁱ		
205992	Benzo(b)fluoranthene	7.30E-1 ^e		
207089	Benzo(k)fluoranthene	7.30E-2 ^e		
65850	Benzoic acid		4.00E+0 ⁱ	
98077	Benzotrichloride	1.30E+1 ⁱ		
100516	Benzyl alcohol		3.00E-1 ^h	
100447	Benzyl chloride	1.70E-1 ⁱ		
7440417	Beryllium	4.30E+0 ⁱ	5.00E-3 ⁱ	
319846	BHC, alpha-	6.30E+0 ⁱ		
319857	BHC, beta-	1.80E+0 ⁱ		
319868	BHC, delta-	1.80E+0		beta-BHC
58899	BHC, gamma- (Lindane)	1.30E+0 ⁱ	3.00E-4 ⁱ	
608731	BHC, technical grade	1.80E+0 ⁱ		

Table E-1. (Continued)

CAS Number	Chemical Name	Cancer Slope Factor (mg/kg/d^{-1}) (Followed by source; see footnotes)	Noncancer Reference Dose (mg/kg/d) (Followed by source; see footnotes)	Surrogate Chemical Used (if necessary)
608731	BHC, technical grade	1.80E+0 ^f		
92524	Biphenyl		5.00E-2 ⁱ	
111444	Bis(2-chloroethyl)ether	1.10E+0 ^f		
108601	Bis(2-chloroisopropyl)ether	7.00E-2 ^h	4.00E-2 ⁱ	
117817	Bis(2-ethylhexyl)phthalate	1.40E-2 ⁱ	2.00E-2 ⁱ	
542881	Bis(chloromethyl)ether	2.20E+2 ⁱ		
7440428	Boron		9.00E-2 ⁱ	
75274	Bromodichloromethane	6.20E-2 ⁱ	2.00E-2 ⁱ	
74839	Bromomethane		1.40E-3 ⁱ	
101553	Bromophenyl phenyl ether, 4-		5.80E-2 ^r	
1689845	Bromoxynil		2.00E-2 ⁱ	
85687	Butyl benzyl phthalate		2.00E-1 ⁱ	
7440439	Cadmium		5.00E-4 ⁱ	
63252	Carbaryl/Sevin		1.00E-1 ⁱ	
1563662	Carbofuran/furadan		5.00E-3 ⁱ	
75150	Carbon disulfide		1.00E-1 ⁱ	
133904	Chloramben		1.50E-2 ⁱ	
57749	Chlordane	1.30E+0 ⁱ	6.00E-5 ⁱ	
5103719	Chlordane, alpha(cis)-	1.30E+0	6.00E-5	chlordane
5103742	Chlordane, beta(trans)-	1.30E+0	6.00E-5	chlordane
5566347	Chlordane, gamma(trans)-	1.30E+0	6.00E-5	chlordane
999999247	Chlordane-nonachlor(cis)-	1.30E+0	6.00E-5	chlordane
999999248	Chlordane-nonachlor(trans)-	1.30E+0	6.00E-5	chlordane
108907	Chlorobenzene		2.00E-2 ⁱ	
510156	Chlorobenzilate	2.70E-1 ^h	2.00E-2 ⁱ	
75003	Chloroethane		4.00E-1 ^e	
75014	Chloroethene	1.90E+0 ^h		
110758	Chloroethylvinyl ether, 2-		2.50E-2 ^r	
74873	Chloromethane	1.30E-2 ^h		
91587	Chloronaphthalene, 2-		8.00E-2 ⁱ	
95578	Chlorophenol, 2-		5.00E-3 ⁱ	
2921882	Chlorpyrifos/Dursban		3.00E-3 ⁱ	

Table E-1. (Continued)

CAS Number	Chemical Name	Cancer Slope Factor (mg/kg/d^{-1}) (Followed by source; see footnotes)	Noncancer Reference Dose (mg/kg/d) (Followed by source; see footnotes)	Surrogate Chemical Used (if necessary)
7440473	Chromium		5.00E-3 ⁱ	
218019	Chrysene	7.30E-3 ^e		
7440508	Copper		3.71E-2 ^h	
108394	Cresol, m-		5.00E-2 ⁱ	
95487	Cresol, o-		5.00E-2 ⁱ	
106445	Cresol, p-		5.00E-3 ^h	
1319773	Cresols		5.00E-3	p-Cresol
98828	Cumene		4.00E-2 ⁱ	
21725462	Cyanazine	8.40E-1 ^h	2.00E-03 ^h	
57125	Cyanide		2.00E-2 ⁱ	
1861321	DCPA/Dacthal		1.00E-2 ⁱ	
53190	DDD, o,p'-	2.40E-1		p,p'-DDD
72548	DDD, p,p'-	2.40E-1 ⁱ		
3424826	DDE, o,p'-	3.40E-1		p,p'-DDE
72559	DDE, p,p'-	3.40E-1 ⁱ		
789026	DDT, o,p'-	3.40E-1	5.00E-4	p,p'-DDT
50293	DDT, p,p'-	3.40E-1 ⁱ	5.00E-4 ⁱ	
999999300	DDT (Total)	3.40E-1	5.00E-4	p,p'-DDT
1163195	Decabromodiphenyl oxide		1.00E-2 ⁱ	
84742	Di-n-butyl phthalate		1.00E-1 ⁱ	
117840	Di-n-octyl phthalate		2.00E-2 ^h	
3334515	Diazinon/Spectracide		9.00E-4 ^h	
53703	Dibenzo(a,h)anthracene	7.30E+0 ^e		
132649	Dibenzofuran		4.00E-3 ^e	
96128	Dibromo-3-chloropropane, 1,2-	1.40E+0 ^h		
124481	Dibromochloromethane	8.40E-2 ⁱ	2.00E-2 ⁱ	
1918009	Dicamba		3.00E-2 ⁱ	
95501	Dichlorobenzene, 1,2-		9.00E-2 ⁱ	
541731	Dichlorobenzene, 1,3-		8.90E-2 ⁱ	
106467	Dichlorobenzene, 1,4-	2.40E-2 ^h		
25321226	Dichlorobenzenes	2.40E-2	8.90E-2	1,3- and 1,4-dichlorobenzene
91941	Dichlorobenzidine, 3,3'-	4.50E-1 ⁱ		

Table E-1. (Continued)

CAS Number	Chemical Name	Cancer Slope Factor (mg/kg/d^{-1}) (Followed by source; see footnotes)	Noncancer Reference Dose (mg/kg/d) (Followed by source; see footnotes)	Surrogate Chemical Used (if necessary)
75718	Dichlorodifluoromethane		2.00E-1 ⁱ	
75343	Dichloroethane 1,1-		1.00E-1 ^h	
107062	Dichloroethane 1,2-	9.10E-2 ⁱ		
75354	Dichloroethene, 1,1-	6.00E-1 ⁱ	9.00E-3 ⁱ	
156605	Dichloroethene, trans-1,2-		2.00E-2 ⁱ	
156592	Dichloroethylene, cis-1,2-		1.00E-2 ^h	
75092	Dichloromethane	7.50E-3 ⁱ	6.00E-2 ⁱ	
120832	Dichlorophenol, 2,4-		3.00E-3 ⁱ	
94757	Dichlorophenoxyacetic acid, 2,4-		1.00E-2 ⁱ	
94826	Dichlorophenoxybutanoic acid, 2,4-		8.00E-3 ⁱ	
78875	Dichloropropane, 1,2-	6.80E-2 ^h		
542756	Dichloropropene, 1,3-	1.75E-1 ^h	3.00E-4 ⁱ	
62737	Dichlorvos	2.90E-1 ⁱ	5.00E-4 ⁱ	
115322	Dicofol/Kelthane	4.40E-1 ^w		
60571	Dieldrin	1.60E+1 ⁱ	5.00E-5 ⁱ	
84662	Diethyl phthalate		8.00E-1 ⁱ	
119904	Dimethoxybenzidine,3,3'-	1.40E-2 ^h		
131113	Dimethyl phthalate		1.00E+1 ^h	
105679	Dimethylphenol, 2,4-		2.00E-2 ⁱ	
528290	Dinitrobenzene, 1,2-		4.00E-4 ^h	
99650	Dinitrobenzene, 1,3-		1.00E-4 ⁱ	
100254	Dinitrobenzene, 1,4-		4.00E-4 ^h	
51285	Dinitrophenol, 2,4-		2.00E-3 ⁱ	
121142	Dinitrotoluene, 2,4-		2.00E-3 ⁱ	
606202	Dinitrotoluene, 2,6-		1.00E-3 ^h	
88857	Dinoseb/DNBP		1.00E-3 ⁱ	
122667	Diphenylhydrazine, 1,2-	8.00E-1 ⁱ		
298044	Disulfoton		4.00E-5 ⁱ	
959988	Endosulfan, alpha-		6.00E-3	endosulfan
33213659	Endosulfan, beta-		6.00E-3	endosulfan
115297	Endosulfan mixed isomers		6.00E-3 ⁱ	
72208	Endrin		3.00E-4 ⁱ	

Table E-1. (Continued)

CAS Number	Chemical Name	Cancer Slope Factor (mg/kg/d) ^a (Followed by source; see footnotes)	Noncancer Reference Dose (mg/kg/d) (Followed by source; see footnotes)	Surrogate Chemical Used (if necessary)
563122	Ethion/Bladen		5.00E-4 ⁱ	
141786	Ethyl acetate		9.00E-1 ⁱ	
100414	Ethylbenzene		1.00E-1 ⁱ	
106934	Ethylene dibromide	8.50E+1 ⁱ		
206440	Fluoranthene		4.00E-2 ⁱ	
86737	Fluorene		4.00E-2 ⁱ	
944229	Fonofos		2.00E-3 ⁱ	
76448	Heptachlor	4.50E+0 ⁱ	5.00E-4 ⁱ	
1024573	Heptachlor epoxide	9.10E+0 ⁱ	1.30E-5 ⁱ	
118741	Hexachlorobenzene	1.60+0 ⁱ	8.00E-4 ⁱ	
87683	Hexachlorobutadiene	7.80E-2 ⁱ	2.00E-4 ^h	
74474	Hexachlorocyclopentadiene		7.00E-3 ⁱ	
67721	Hexachloroethane	1.40E-2 ⁱ	1.00E-3 ⁱ	
51235042	Hexazinone		3.30E-2 ⁱ	
123319	Hydroquinone		4.00E-2 ^h	
193395	Indeno(1,2,3-cd)pyrene	7.30E-1 ^e		
78591	Isophorone	9.50E-4 ⁱ	2.00E-1 ⁱ	
33820530	Isopropalin		1.50E-2 ⁱ	
121755	Malathion		2.00E-2 ⁱ	
108316	Maleic anhydride		1.00E-1 ⁱ	
7439965	Manganese		5.00E-3 ⁱ	
7439976	Mercury		1.00E-4 ⁱ	methyl mercury
72435	Methoxychlor		5.00E-3 ⁱ	
78933	Methyl ethyl ketone		6.00E-1 ⁱ	
108101	Methyl isobutyl ketone		8.00E-2 ^h	
22967926	Methyl mercury		1.00E-4 ⁱ	
21087649	Metribuzin		2.50E-2 ⁱ	
2385855	Mirex/Decchlorane	1.80E+0 ^w	2.00E-4 ⁱ	
7439987	Molybdenum		5.00E-3 ⁱ	
91203	Napthalene		4.00E-2 ^w	
91598	Napthylamine, 2-	1.30E+2 ^e		
7440020	Nickel		2.00E-2 ⁱ	

Table E-1. (Continued)

CAS Number	Chemical Name	Cancer Slope Factor (mg/kg/d^{-1}) (Followed by source; see footnotes)	Noncancer Reference Dose (mg/kg/d) (Followed by source; see footnotes)	Surrogate Chemical Used (if necessary)
98953	Nitrobenzene		5.00E-4 ⁱ	
100027	Nitrophenol, 4		6.20E-2 ^o	
924163	Nitrosodi-n-butylamine, N-	5.40E+0 ^f		
621647	Nitrosodi-n-propylamine, N-	7.00E+0 ^f		
55185	Nitrosodiethylamine, N-	1.50E+2 ^f		
86306	Nitrosodiphenylamine, N-	4.90E-3 ^f		
56382	Parathion ethyl		6.00E-3 ^h	
12674112	PCB(Arochlor-1016)	7.70E+0	7.00E-5 ⁱ	
11104282	PCB(Arochlor-1221)	7.70E+0	2.00E-5 ⁱ	
11141165	PCB(Arochlor-1232)	7.70E+0	2.00E-5 ⁱ	
53469219	PCB(Arochlor-1242)	7.70E+0	2.00E-5 ⁱ	
12672296	PCB(Arochlor-1248)	7.70E+0	2.00E-5 ⁱ	
11097691	PCB(Arochlor-1254)	7.70E+0	2.00E-5 ⁱ	
11096825	PCB(Arochlor-1260)	7.70E+0	2.00E-5 ⁱ	
608935	Pentachlorobenzene		8.00E-4 ⁱ	
82688	Pentachloronitrobenzene/Quitoxe		2.60E-1 ^h	
87685	Pentachlorophenol	1.20E-1 ⁱ	3.00E-2 ^f	
108952	Phenol		6.00E-1 ⁱ	
298022	Phorate/Famophos/Thimet		2.00E-4 ^h	
85449	Phthalic anhydride		2.00E-0 ^f	
1336363	Polychlorinated biphenyls	7.70E+0 ^f	2.00E-5 ⁱ	
1610180	Prometon/Pramitol		1.50E-2 ^f	
7287196	Prometym/Caparol		4.00E-3 ^f	
23950585	Pronamide		7.50E-2 ^f	
1918167	Propachlor		1.30E-2 ^f	
129000	Pyrene		3.00E-2 ^f	
91225	Quinoline	1.20E+1 ^h		
7782492	Selenium		5.00E-3 ^f	
7440224	Silver		5.00E-3 ^f	
122349	Simazine	1.20E-1 ^h	5.00E-3 ^f	
122349	Strontium		6.00E-1 ⁱ	
100425	Styrene		2.00E-1 ⁱ	

Table E-1. (Continued)

CAS Number	Chemical Name	Cancer Slope Factor (mg/kg/d) ¹ (Followed by source; see footnotes)	Noncancer Reference Dose (mg/kg/d) (Followed by source; see footnotes)	Surrogate Chemical Used (if necessary)
13071799	Terbufos/Counter		2.50E-5 ^a	
886500	Terbutryn		1.00E-3 ⁱ	
95943	Tetrachlorobenzene, 1,2,4,5-		3.00E-4 ⁱ	
1746016	Tetrachlorodibenzo-p-dioxin, 2,3,7,8-	1.56E+5 ^b		
79345	Tetrachloroethane, 1,1,2,2-	2.00E-1 ⁱ		
127184	Tetrachloroethene	5.20E-2 ^e	1.00E-2 ⁱ	
56235	Tetrachloromethane	1.30E-1 ⁱ	7.00E-4 ⁱ	
58902	Tetrachlorophenol, 2,3,4,6-		3.00E-2 ⁱ	
961115	Tetrachlorvinphos/Gardona/Stirof	2.40E-2 ^b	3.00E-2 ⁱ	
7440315	Tin		6.00E-1 ^b	
108883	Toluene		2.00E-1 ⁱ	
8001352	Toxaphene	1.10E+0 ⁱ		
75252	Tribromomethane (Bromoform)	7.90E-3 ⁱ	2.00E-2 ⁱ	
120821	Trichlorobenzene, 1,2,4-		1.00E-2 ⁱ	
71556	Trichloroethane, 1,1,1-		9.00E-2 ^w	
79005	Trichloroethane, 1,1,2-	5.70E-2 ⁱ	4.00E-3 ⁱ	
79016	Trichloroethene	1.10E-2 ^w	6.00E-3 ^e	
75694	Trichlorofluoromethane		3.00E-1 ⁱ	
67663	Trichloromethane (Chloroform)	6.10E-3 ⁱ	1.00E-2 ⁱ	
95954	Trichlorophenol, 2,4,5-		1.00E-1 ⁱ	
88062	Trichlorophenol, 2,4,6-	1.10E-2 ⁱ		
93765	Trichlorophenoxyacetic acid, 2,4,5-		1.00E-2 ⁱ	
93721	Trichlorophenoxypropionic acid, 2,4,5-		8.00E-3 ⁱ	
1582098	Trifluralin/Treflan	7.70E-3 ⁱ	7.50E-3 ⁱ	
95636	Trimethylbenzene, 1,2,4-		5.00E-4 ^e	
118967	Trinitrotoluene	3.00E-2 ⁱ	5.00E-4 ⁱ	
7440622	Vanadium		7.00E-3 ^b	
108054	Vinyl acetate		1.00E+0 ^b	
108383	Xylene, m-		2.00E+0 ^b	
95476	Xylene, o-		2.00E+0 ^b	
1330207	Xylenes		2.00E+0 ⁱ	
7440666	Zinc		3.00E-1 ⁱ	

Codes:

¹Integrated Risk Information System (IRIS).

²Health Effects Assessment Summary Tables (HEAST).

³Environmental Criteria and Assessment Office (ECAO, as cited in Risk-Based Concentration Table).

⁴Other EPA documents, as cited in Risk-Based Concentration Table.

^{*}Withdrawn from HEAST, but use continued for screening assessments (USEPA, Risk-Based Concentration Table).

Appendix F

Species Characteristics Related to NSI Bioaccumulation Data

Table F-1 presents the species used in tissue residue analyses whose results are included in the NSI. For each species listed, Table F-1 identifies the species as resident or migratory (or either) and demersal or pelagic (or either) and specifies whether the species might be consumed by humans (i.e., recreational or subsistence anglers). A species is considered either resident or migratory if it stays predominately in one location as long as food and habitat are available but is capable of traveling long distances to find food and suitable habitat. A species is considered either demersal or pelagic if it spends much of its time in the water column but is likely to feed off the bottom. If a species is identified as either resident or migratory, it is considered resident for the purpose of this analysis. If a species is identified as either demersal or pelagic, it is considered demersal.

Table F-1. Species Characteristics Related to Tissue Residue Data

Species Code	Scientific Name	Common Name	Resident/Migratory ^a	Demersal/Pelagic ^b	Potentially Eatable
615301010400	<i>Acanthomysis macropsis</i>	Mysid shrimp	E	E	
611829010000	<i>Acartia</i> spp.	Copepod (unknown species)	M	P	
872901010000	<i>Acipenser</i> spp.	Sturgeon (unknown Species)	M	D	Y
872901010600	<i>Acipenser fulvescens</i>	Lake sturgeon	R	D	Y
872901010500	<i>Acipenser oxyrhynchus</i>	Atlantic sturgeon	M	D	Y
872901010300	<i>Acipenser transmontanus</i>	White sturgeon	M	D	Y
877601200100	<i>Acrocheilus alutaceus</i>	Chiselmouth	R	P	
875503060100	<i>Allosmerus elongatus</i>	Whitebaik smelt	M	P	Y
874701010200	<i>Alosa aestivalis</i>	Blueback herring	M	P	Y
874701010600	<i>Alosa chrysochloris</i>	Skipjack herring	M	P	Y
874701010300	<i>Alosa mediocris</i>	Hickory shad	M	P	Y
874701010500	<i>Alosa pseudoharengus</i>	Alewife	M	P	Y
874701010100	<i>Alosa sapidissima</i>	American shad	M	P	Y
883516020200	<i>Ambloplites cavifrons</i>	Roanoke bass	R	P	Y
883516020100	<i>Ambloplites rupestris</i>	Rock bass	R	P	Y
877702060100	<i>Ameiurus brunneus</i>	Snail bullhead	R	D	Y
877702060200	<i>Ameiurus catus</i>	White catfish	R	D	Y
877702060300	<i>Ameiurus melas</i>	Black bullhead	R	D	Y
877702060400	<i>Ameiurus natalis</i>	Yellow bullhead	R	D	Y
877702060500	<i>Ameiurus nebulosus</i>	Brown bullhead	R	D	Y
877702060600	<i>Ameiurus platycephalus</i>	Flat bullhead	R	D	Y
877702060700	<i>Ameiurus serracanthus</i>	Spotted bullhead	R	D	Y
873401010100	<i>Amia calva</i>	Bowfin	R	E	Y
884202010200	<i>Anarhichas denticulatus</i>	Northern wolffish	R	D	Y
874101010100	<i>Anguilla rostrata</i>	American eel	M	P	Y
883544260100	<i>Aplodinotus grunniens</i>	Freshwater drum	M	E	Y
883516090100	<i>Archoplites interruptus</i>	Sacramento perch	R	P	Y
883543030100	<i>Archosargus probatocephalus</i>	Sheepshead	M	P	Y
551539010100	<i>Arctica islandica</i>	Ocean quahog	R	D	Y
877718020200	<i>Arius felis</i>	Hardhead catfish	M	D	Y
883102040500	<i>Artedius notospilotus</i>	Bonehead sculpin	R	D	
618102000000	<i>Astacidae</i>	Crayfish (family)	R	D	Y

Table F-1. (Continued)

Species Code	Scientific Name	Common Name	Resident/Migratory ^a	Demersal/Pelagic ^b	Potentially Eatable
551519010000	<i>Astarte</i> spp.	Astarte clam (Unknown species)	R	D	
551519011300	<i>Astarte undata</i>	Waved astarte	R	D	
883561010100	<i>Astronotus ocellatus</i>	Oscar	R	P	Y
810601051100	<i>Astropecten verrilli</i>	Margined seastar	R	D	
877718010100	<i>Bagre marinus</i>	Gafftopsail catfish	M	E	Y
883544030100	<i>Bairdiella chrysoura</i>	Silver perch	M	P	Y
550000000000	<i>Bivalvia</i>	Class of molluscs	R	D	Y
550701160100	<i>Brachiodontes recurvus</i>	Hooked mussel	R	D	Y
874701040000	<i>Brevoortia</i> spp.	Menhaden (unknown species)	M	P	Y
874701040100	<i>Brevoortia tyrannus</i>	Atlantic menhaden	M	P	Y
618901030100	<i>Callinectes sapidus</i>	Blue crab	M	D	Y
618105010600	<i>Cambarus bartoni</i>	Crayfish	R	D	Y
877601140100	<i>Campostoma anomalum</i>	Central stoneroller	R	E	
618803010400	<i>Cancer magister</i>	Dungeness crab	M	D	Y
883528030300	<i>Caranx hippos</i>	Crevalle jack	M	P	Y
877601030100	<i>Carassius auratus</i>	Goldfish	R	E	
870802050100	<i>Carcharhinus obscurus</i>	Dusky shark	M	E	Y
870802050300	<i>Carcharhinus plumbeus</i>	Brown shark (sandbar)	M	E	Y
877604020000	<i>Carpiodes</i> spp.	Carp sucker (unknown species)	R	D	Y
877604020200	<i>Carpiodes carpio</i>	River carp sucker	R	D	Y
877604020100	<i>Carpiodes cyprinus</i>	Quillback	R	D	Y
877604020300	<i>Carpiodes velifer</i>	Highfin carp sucker	R	D	Y
877604010000	<i>Catostomus</i> spp.	Sucker (unknown sp)	R	D	Y
877604010500	<i>Catostomus ardens</i>	Utah sucker	R	D	Y
877604010100	<i>Catostomus catostomus</i>	Longnose sucker	R	D	Y
877604010400	<i>Catostomus columbianus</i>	Bridgelp sucker	R	D	Y
877604010200	<i>Catostomus commersoni</i>	White sucker	R	D	Y
877604011200	<i>Catostomus latipinnis</i>	Flannelmouth sucker	R	D	Y
877604010300	<i>Catostomus macrocheilus</i>	Largescale sucker	R	D	Y
877604011500	<i>Catostomus occidentalis</i>	Sacramento sucker	R	D	Y
877604011600	<i>Catostomus platyrhynchus</i>	Mountain sucker	R	D	Y
877604012000	<i>Catostomus snyderi</i>	Klamath largescale sucker	R	D	Y

Table F-1. (Continued)

Species Code	Scientific Name	Common Name	Resident/Migratory ^a	Demersal/Pelagic ^b	Potentially Eatable
877604012100	<i>Catostomus tahoensis</i>	Tahoe sucker	R	D	Y
883516000000	<i>Centrarchidae</i>	Sunfish family	R	P	Y
883516030100	<i>Centrarchus macropterus</i>	Flier	R	P	Y
883501010500	<i>Centropomus undecimalis</i>	Common snook	M	P	Y
883502030100	<i>Centropristis striata</i>	Black sea bass	M	P	Y
900201010100	<i>Chelydra serpentina</i>	Snapping turtle	R	E	Y
648933000000	<i>Chironomidae</i>	Midge family	R	D	
648960063300	<i>Chironomus riparius</i>	Midge	R	D	
883561090100	<i>Cichla ocellaris</i>	Peacock cichlid	R	P	Y
885703010100	<i>Citharichthys sordidus</i>	Pacific sanddab	E	D	
885703011100	<i>Citharichthys xanthostigma</i>	Longfin sanddab	E	D	
877712010200	<i>Cichla Clarias fuscus</i>	Whitespotted clarias	M	D	Y
877601070100	<i>Clinostomus funduloides</i>	Rosyside dace	R	P	
551545020100	<i>Corbicula manilensis</i>	Asiatic clam	R	D	Y
875501010800	<i>Coregonus artedii</i>	Cisco (lake herring)	M	P	Y
875501010600	<i>Coregonus clupeaformis</i>	Lake whitefish	M	P	Y
875501010900	<i>Coregonus hoyi</i>	Bbater	M	P	Y
883102000000	<i>Cottidae</i>	Sculpin family	R	D	Y
883102080000	<i>Cottus</i> spp.	Sculpin (unknown species)	R	D	
883102080100	<i>Cottus aleuticus</i>	Coastrange sculpin	R	D	
883102080700	<i>Cottus bairdi</i>	Mottled sculpin	R	D	
883102080900	<i>Cottus carolinae</i>	Banded sculpin	R	D	
883102080200	<i>Cottus cognatus</i>	Slimy sculpin	R	D	
551002010000	<i>Crassostrea</i> spp.	Oysters (unknown species)	R	D	Y
551002010100	<i>Crassostrea gigas</i>	Pacific oyster	R	D	Y
551002010200	<i>Crassostrea virginica</i>	Eastern oyster	R	D	Y
877601230100	<i>Ctenopharyngodon idella</i>	Grass carp	R	E	Y
877604060100	<i>Cycleptus elongatus</i>	Blue sucker	M	D	Y
883544010200	<i>Cynoscion nebulosus</i>	Spotted sea trout	R	P	Y
883544010300	<i>Cynoscion nothus</i>	Silver sea trout	M	P	Y
883544010400	<i>Cynoscion regalis</i>	Weakfish	M	P	Y
877601761400	<i>Cyprinella lutrensis</i>	Red shiner	R	P	

Table F-1. (Continued)

Species Code	Scientific Name	Common Name	Resident/Migratory ^a	Demersal/Pelagic ^b	Potentially Eatable
877601761900	<i>Cyprinella spiloptera</i>	Spotfin shiner	R	P	
877601000000	<i>Cyprinidae</i>	Carp/goldfish (hybrid)	R	E	Y
877601010100	<i>Cyprinus carpio</i>	Common carp	R	D	Y
871305010500	<i>Dasyatis sabina</i>	Atlantic stingray	M	D	Y
874701050100	<i>Dorosoma cepedianum</i>	Gizzard shad	M	P	
874701050200	<i>Dorosoma petenense</i>	Threadfin shad	M	P	
551202030100	<i>Elliptio complanata</i>	Freshwater clam	?	D	Y
885704040300	<i>Eopsetta exilis</i>	Slender sole	E	D	Y
883544120500	<i>Equetus punctatus</i>	Spotted drum	R	D	
877604030000	<i>Erimyzon</i> spp.	Chubsucker (unknown species)	R	E	
877604030200	<i>Erimyzon oblongus</i>	Creek chubsucker	R	E	
877604030100	<i>Erimyzon sucetta</i>	Lake chubsucker	R	E	
875801000000	<i>Esocidae</i>	Pike	R	P	Y
875801010201	<i>Esox americanus americanus</i>	Redfin pickerel	R	P	Y
875801010202	<i>Esox americanus vermiculatus</i>	Grass pickerel	R	P	Y
875801010100	<i>Esox lucius</i>	Northern pike	R	P	Y
875801010400	<i>Esox masquinongy</i>	Muskellunge	R	P	Y
875801010300	<i>Esox niger</i>	Chain pickerel	R	P	Y
883520016700	<i>Etheostoma radiosum</i>	Orangebelly darter	R	D	
883520010900	<i>Etheostoma spectabile</i>	Orangethroat darter	R	D	
883520017600	<i>Etheostoma stigmaeum</i>	Speckled darter	R	D	
883520018700	<i>Etheostoma whipplei</i>	Redfin darter	R	D	
883520018800	<i>Etheostoma zonale</i>	Banded darter	R	D	
880404021000	<i>Fundulus zebrinus</i>	Plains killifish	R	P	
880404021100	<i>Fundulus olivaceus</i>	Blackspotted topminnow	R	P	
879103040100	<i>Gadus macrocephalus</i>	Pacific cod	M	E	Y
870802020100	<i>Galeocerdo cuvier</i>	Tiger shark	M	E	Y
880408010100	<i>Gambusia affinis</i>	Western mosquitofish	R	P	
883544020100	<i>Genyonemus lineatus</i>	White croaker	M	E	Y
877601260000	<i>Gila</i> spp.	Chub (unknown species)	R	E	
877601261500	<i>Gila robusta</i>	Roundtail chub	R	E	
883551020100	<i>Girella nigricans</i>	Opaleye	M	P	

Table F-1. (Continued)

Species Code	Scientific Name	Common Name	Resident/Migratory ^a	Demersal/Pelagic ^b	Potentially Eatable
885704350100	<i>Glyptocephalus zachti</i>	Rex sole	E	D	
551202060100	<i>Gonidea angulata</i>	Freshwater mussel	R	D	Y
874701000000	<i>Glupeidae</i>	Herring family	M	P	Y
622003030000	<i>Hexagenia</i> spp.	Burrowing mayfly (unknown species)	R	D	
622003030700	<i>Hexagenia limbata</i>	Mayfly	R	D	
875101010100	<i>Hiodon alosoides</i>	Gokleye	M	P	Y
875101010200	<i>Hiodon tergisus</i>	Mooneye	M	P	Y
885703110200	<i>Hippoglossina stomata</i>	Bigmouth sole	M	D	Y
885704060100	<i>Hippoglossoides elas</i>	Flathead sole	M	D	Y
885704060300	<i>Hippoglossoides platessoides</i>	American plaice	M	D	Y
616923040100	<i>Hyalella azteca</i>	Freshwater amphipod	R	E	
877601050300	<i>Hybognathus placitus</i>	Plains minnow	R	P	
871602010100	<i>Hydrolagus colliei</i>	Spotted rat fish	M	D	
877604050100	<i>Hypentelium nigricans</i>	Northern hog sucker	R	D	Y
875503010100	<i>Hypomesus pretiosus</i>	Surf smelt	M	P	Y
885704220100	<i>Hypsopsetta guttulata</i>	Diamond turbot	?	D	Y
877702000000	<i>Ictaluridae</i>	Bullhead catfish family	R	D	Y
877702010000	<i>Ictalurus</i> spp.	Catfish (unknown species)	R	D	Y
877702010200	<i>Ictalurus furcatus</i>	Blue catfish	R	D	Y
877702010500	<i>Ictalurus punctatus</i>	Channel catfish	R	D	Y
877604070100	<i>Ictiobus bubalus</i>	Smallmouth buffalo	R	E	Y
877604070200	<i>Ictiobus cyprinellus</i>	Bigmouth buffalo	R	E	Y
877604070300	<i>Ictiobus niger</i>	Black buffalo	R	E	Y
883543020100	<i>Lagodon rhomboides</i>	Pinfish	E	P	
870600000000	<i>Lamniformes</i>	Shark	M	P	Y
877601300100	<i>Lavinia exilicauda</i>	Häich	R	P	
883544040100	<i>Leiostomus xanthurus</i>	Spot	M	P	Y
884701030100	<i>Lepidogobius lepidus</i>	Bay goby	R	P	
873201010000	<i>Lepisosteus</i> spp.	Gar (unknown species)	E	P	Y
873201010200	<i>Lepisosteus oculatus</i>	Spotted gar	E	P	Y
873201010100	<i>Lepisosteus osseus</i>	Longnose gar	E	P	Y
873201010300	<i>Lepisosteus platostomus</i>	Shortnose gar	E	P	Y

Table F-1. (Continued)

Species Code	Scientific Name	Common Name	Resident/Migratory ^a	Demersal/Pelagic ^b	Potentially Eatable
873201010400	<i>Lepisosteus spatula</i>	Alligator gar	E	P	Y
883516050000	<i>Lepomis</i> spp.	Sunfish (unknown species)	R	P	Y
883516050100	<i>Lepomis auritus</i>	Redbreast sunfish	R	P	Y
883516050200	<i>Lepomis cyanellus</i>	Green sunfish	R	P	Y
883516050500	<i>Lepomis gibbosus</i>	Pumpkinseed	R	P	Y
883516050300	<i>Lepomis gulosus</i>	Warmouth	R	P	Y
883516050600	<i>Lepomis humilis</i>	Orangespotted sunfish	R	P	Y
883516050400	<i>Lepomis macrochirus</i>	Bluegill	R	P	Y
883516050700	<i>Lepomis marginatus</i>	Dollar sunfish	R	P	Y
883516050800	<i>Lepomis megalotis</i>	Longear sunfish	R	P	Y
883516050900	<i>Lepomis microlophus</i>	Redear sunfish	R	P	Y
883516051000	<i>Lepomis punctatus</i>	Spotted sunfish	R	P	Y
879103080100	<i>Lota lota</i>	Burbot	M	E	Y
618701150200	<i>Loxorhynchus grandis</i>	Decorator crab	R	D	
500501010300	<i>Lumbriculus variegatus</i>	Aquatic worm	R	D	
883536010700	<i>Lutjanus campechanus</i>	Red snapper	M	D	Y
877601780400	<i>Luxilus chrysocephalus</i>	Striped shiner	R	P	
877601780600	<i>Luxilus cornutus</i>	Common shiner	R	P	
885704110100	<i>Lyopsetta exilis</i>	Slender sole	M	D	Y
814802010600	<i>Lytechinus anamesus</i>	Little gray sea urchin	R	D	
551531013600	<i>Macoma irus</i>	Clam (macoma)	R	D	Y
551531011400	<i>Macoma nasuta</i>	Bent-nosed macoma	R	D	
877601800200	<i>Macrhybopsis gelida</i>	Surgeon chub	R	E	
551202430300	<i>Megalonias gigantea</i>	Washboard mussel	R	D	Y
551547110100	<i>Mercenaria mercenaria</i>	Quahog	R	D	Y
883544070100	<i>Micropogonias undulatus</i>	Atlantic croaker	M	P	Y
883516060000	<i>Micropterus</i> spp.	Bass (unknown species)	R	P	Y
883516060500	<i>Micropterus coosae</i>	Redeye bass	R	P	Y
883516060100	<i>Micropterus dolomieu</i>	Smallmouth bass	R	P	Y
883516060600	<i>Micropterus notius</i>	Swanee bass	R	P	Y
883516060300	<i>Micropterus punctulatus</i>	Spotted bass	R	P	Y
883516060200	<i>Micropterus salmoides</i>	Largemouth Bass	R	P	Y

Table F-1. (Continued)

Species Code	Scientific Name	Common Name	Resident/Migratory ^a	Demersal/Pelagic ^b	Potentially Eatable
877604080100	<i>Minytrema melanops</i>	Spotted sucker	E	D	Y
883502010000	<i>Morone</i> spp.	Temperate bass (unknown species)	E	P	Y
883502010100	<i>Morone americana</i>	White perch	M	P	Y
883502010400	<i>Morone chrysops</i>	White bass	M	P	Y
883502010300	<i>Morone chrysops x saxatilis</i>	Hybrid striped bass (white/striped)	E	P	Y
883502010500	<i>Morone mississippiensis</i>	Yellow bass	M	P	Y
883502010200	<i>Morone saxatilis</i>	Striped bass	M	P	Y
877604040000	<i>Moxostoma</i> spp.	Redhorse (unknown species)	R	D	Y
877604040400	<i>Moxostoma anisurum</i>	Silver redhorse	R	D	Y
877604040700	<i>Moxostoma carinatum</i>	River redhorse	R	D	Y
877604040200	<i>Moxostoma congestum</i>	Gray redhorse	R	D	Y
877604040900	<i>Moxostoma duquesnei</i>	Black redhorse	R	D	Y
877604041000	<i>Moxostoma erythrurum</i>	Golden redhorse	R	D	Y
877604040100	<i>Moxostoma macrolepidotum</i>	Shorthead redhorse	R	D	Y
877604041400	<i>Moxostoma pappilosum</i>	V-lip redhorse	R	D	Y
877604040300	<i>Moxostoma poecilurum</i>	Blacktail redhorse	R	D	Y
877604041700	<i>Moxostoma rupiscartes</i>	Striped jumprock	R	D	Y
883601010100	<i>Mugil cephalus</i>	Striped mullet	M	E	Y
883601010200	<i>Mugil curema</i>	White mullet	M	E	Y
870802040100	<i>Mustelus canis</i>	Smooth dogfish	M	E	Y
551701020100	<i>Mya arenaria</i>	Soft clam	R	D	Y
877601170100	<i>Mylocheilus caurinus</i>	Peamouth	R	E	
877601350100	<i>Mylopharodon conocephalus</i>	Hardhead	R	E	
550701010000	<i>Mytilus</i> spp.	Mussel (unknown species)	R	D	Y
550701010200	<i>Mytilus californianus</i>	California mussel	R	D	Y
550701010100	<i>Mytilus edulis</i>	Blue mussel	R	D	Y
500124030500	<i>Neanthes arenaceodentata</i>	Sand worm	R	D	
500168040100	<i>Neoamphrite robusta</i>	Terrebellid worm	R	D	
500125011900	<i>Nephtys caecoides</i>	Sand worm	R	D	
500168040100	<i>Neoamphrite robusta</i>	Terrebellid worm	R	D	
500125011900	<i>Nephtys caecoides</i>	Sand worm	R	D	
500125011500	<i>Nephtys incisa</i>	Red-lined worm	R	D	

Table F-1. (Continued)

Species Code	Scientific Name	Common Name	Resident/Migratory ^a	Demersal/Pelagic ^b	Potentially Eatable
877601100300	<i>Nocomis asper</i>	Redspot chub	R	E	
877601100200	<i>Nocomis leptocephalus</i>	Bluehead chub	R	E	
877601100100	<i>Nocomis micropogon</i>	River chub	R	E	
877601060100	<i>Notemigonus crysoleucas</i>	Golden shiner	M	P	
877601501000	<i>Notropis amblops</i>	Bigeye chub	R	E	
877601114100	<i>Notropis boops</i>	Bigeye shiner	R	P	
877601111400	<i>Notropis buchmanii</i>	Ghost shiner	R	P	
877601110600	<i>Notropis hudsonius</i>	Spottail shiner	R	P	
877601118100	<i>Notropis nubilus</i>	Ozark minnow	R	E	
877601112300	<i>Notropis stramineus</i>	Sand shiner	R	P	
877702020200	<i>Noturus insignis</i>	Margined madtom	R	D	
877702021800	<i>Noturus miurus</i>	Brindled madtom	R	D	
877702022000	<i>Noturus phaeus</i>	Brown madtom	R	D	
870703010100	<i>Odontaspis taurus</i>	Sand tiger	M	E	Y
500300000000	<i>Oligochaetes</i>	Aquatic worms	R	D	
875501020800	<i>Oncorhynchus clarki</i>	Cutthroat trout	E	P	Y
875501020100	<i>Oncorhynchus gorbuscha</i>	Pink salmon	M	P	Y
875501021100	<i>Oncorhynchus mykiss</i>	Rainbow trout	E	P	Y
875501020300	<i>Oncorhynchus kisutch</i>	Coho salmon	M	P	Y
875501020500	<i>Oncorhynchus nerka</i>	Sockeye salmon	M	E	Y
875501020600	<i>Oncorhynchus tshawytscha</i>	Chinook salmon	M	E	Y
878301020000	<i>Opsanus</i> spp.	Toadfish (unknown species)	R	D	
618105030000	<i>Orconectes</i> spp.	Crayfish	R	D	Y
877601360100	<i>Orthodon microlepidotus</i>	Sacramento blackfish	R	P	
883540020100	<i>Orthopristis chrysoptera</i>	Pigfish	R	P	Y
875503000000	<i>Osmeridae</i>	Smelt (species unknown)	M	P	Y
875503030200	<i>Osmerus mordax</i>	Rainbow smelt	M	P	Y
618102020100	<i>Pacifastacus leniusculus</i>	Crayfish	R	D	Y
617918010100	<i>Pandalus borealis</i>	Maine shrimp	R	D	
883502160400	<i>Paralabrax nebulifer</i>	Barred sand bass	E	D	Y
885703030900	<i>Paralichthys californicus</i>	California halibut	M	D	Y
885703030100	<i>Paralichthys dentatus</i>	Summer flounder (fluke)	M	D	Y

Table F-1. (Continued)

Species Code	Scientific Name	Common Name	Resident/Migratory ^a	Demersal/Pelagic ^b	Potentially Eatable
885703030400	<i>Paralichthys lethostigma</i>	Southern flounder	M	D	Y
817502010100	<i>Parastichopus californicus</i>	California sea cucumber	R	D	
500166030400	<i>Pectinaria californiensis</i>	Sandworm	R	D	
617701010000	<i>Penaeus</i> spp.	Shrimp	R	D	Y
617701010100	<i>Penaeus aztecus</i>	Brown shrimp	R	E	Y
617701010300	<i>Penaeus setiferus</i>	White shrimp	R	E	Y
883520020100	<i>Perca flavescens</i>	Yellow perch	R	P	Y
883520030900	<i>Percina copelandi</i>	Channel darter	R	D	
883560050100	<i>Phanerodon furcatus</i>	White seaperch	R	P	Y
877601370300	<i>Phoxinus erythrogaster</i>	Southern redbelly dace	R	P	
877601160200	<i>Pimephales promelas</i>	Fathead minnow	R	P	
811703050100	<i>Pisaster brevispinus</i>	Starfish	R	D	
550905090100	<i>Placopecten magellanicus</i>	Atlantic deep-sea scallop	R	D	
885704140100	<i>Platichthys stellatus</i>	Starry flounder	M	D	Y
877601840100	<i>Platygobio gracilis</i>	Flathead chub	R	E	
885704151000	<i>Pleuronectes bilineatus</i>	Rock sole	E	D	Y
885704130100	<i>Pleuronectes vetulus</i>	English sole	M	D	Y
885704000000	<i>Pleuronectidae</i>	Righteye flounder family	M	D	Y
885704160200	<i>Pleuronichthys decurrens</i>	Curfin sole	M	D	Y
885704160400	<i>Pleuronichthys verticalis</i>	Hornyhead turbot	M	D	Y
880408110200	<i>Poecilia vittata</i>	Cuban limia	E	P	
883544080100	<i>Pogonias cromis</i>	Black drum	M	P	Y
872902010100	<i>Polyodon spathula</i>	Paddlefish	M	P	Y
883525010100	<i>Pomatomus saltatrix</i>	Bluefish	M	P	Y
883516070000	<i>Pomoxis</i> spp.	Crappie (unknown species)	R	P	Y
883516070100	<i>Pomoxis annularis</i>	White crappie	R	P	Y
883516070200	<i>Pomoxis nigromaculatus</i>	Black crappie	R	P	Y
882602010100	<i>Prionotus carolinus</i>	Northern searobin	R	D	Y
875501060100	<i>Prosopium cylindraceum</i>	Round whitefish	M	P	Y
875501060200	<i>Prosopium williamsoni</i>	Mountain whitefish	M	P	Y
551547070100	<i>Protothaca staminea</i>	Clam (Pacific littleneck)	R	D	Y
885704150400	<i>Pleuronectes americanus</i>	Winter flounder	M	D	Y

Table F-1. (Continued)

Species Code	Scientific Name	Common Name	Resident/Migratory ^a	Demersal/Pelagic ^b	Potentially Eatable
885704150400	<i>Pleuronectes americanus</i>	Winter flounder	M	D	Y
877601180000	<i>Ptychocheilus</i> spp.	Squawfish	R	E	Y
877601180100	<i>Ptychocheilus oregonensis</i>	Northern squawfish	R	E	Y
877702030100	<i>Pylodictis olivaris</i>	Flathead catfish	R	E	Y
871304010300	<i>Raja binoculata</i>	Winter skate	M	D	Y
890302010600	<i>Rana catesbeiana</i>	Bullfrog	?	P	Y
551525040100	<i>Rangia cuneata</i>	Brackish water clam	R	D	Y
877601090000	<i>Rhinichthys</i> spp.	Dace (unknown species)	R	D	
877601190100	<i>Richardsonius balteatus</i>	Redside shiner	R	P	
875501030000	<i>Salmo</i> spp.	Trout (unknown species)	E	P	Y
875501030500	<i>Salmo salar</i>	Atlantic salmon	M	P	Y
875501030600	<i>Salmo trutta</i>	Brown trout	E	P	Y
875501000000	<i>Salmonidae</i>	Trout (family)	E	P	Y
875501040000	<i>Salvelinus hybrid</i>	Splake (hybrid)	E	P	Y
875501040400	<i>Salvelinus fontinalis</i>	Brook trout	E	P	Y
875501040100	<i>Salvelinus malma</i>	Dolly varden	E	P	Y
875501040300	<i>Salvelinus namaycush</i>	Lake trout	E	P	Y
551547020100	<i>Saxidomus giganteus</i>	Clam (smooth washington)	R	D	Y
872901020200	<i>Scaphirhynchus platyrhynchus</i>	Shovelnose sturgeon	M	D	Y
883544000000	<i>Sciaenidae</i>	Drum family	M	E	Y
883544090100	<i>Sciaenops ocellatus</i>	Red drum	M	E	Y
885003030100	<i>Scomber japonicus</i>	Chub mackerel	M	P	Y
885003050100	<i>Scomberomorus cavalla</i>	King mackerel	M	P	Y
885003050200	<i>Scomberomorus maculatus</i>	Spanish mackerel	M	P	Y
885703040100	<i>Scophthalmus aquosus</i>	Windowpane	M	D	Y
882601061600	<i>Scorpaena guttata</i>	California scorpionfish	R	D	Y
883102310100	<i>Scorpaenichthys marmoratus</i>	Cabezon	R	D	
882601010300	<i>Sebastes auriculatus</i>	Brown rockfish	M	P	Y
882601012000	<i>Sebastes maliger</i>	Quillback rockfish	M	P	Y
882601012100	<i>Sebastes melanops</i>	Black rockfish	M	P	Y
882601013900	<i>Sebastes norvegicus</i>	Golden redfish	M	P	Y
882601012700	<i>Sebastes paucispinis</i>	Bocaccio	M	P	Y

Table F-1. (Continued)

Species Code	Scientific Name	Common Name	Resident/Migratory ^a	Demersal/Pelagic ^b	Potentially Eatable
882601012700	<i>Sebastes paucispinis</i>	Bocaccio	M	P	Y
882601013000	<i>Sebastes proriger</i>	Redstripe rockfish	M	P	Y
877601080200	<i>Semotilus atromaculatus</i>	Creek chub	R	E	
877601080100	<i>Semotilus corporalis</i>	Fallfish	R	E	
877601080300	<i>Semotilus lumbee</i>	Sandhills crab	R	E	
617704010900	<i>Sicyonia ingentis</i>	Rock shrimp	R	D	
551529020100	<i>Solen sicarius</i>	Razor clam	R	D	
871001020100	<i>Squalus acanthias</i>	Spiny dogfish	M	E	Y
883520040200	<i>Stizostedion canadense</i>	Sauger	R	P	Y
883520040100	<i>Stizostedion vitreum</i>	Walleye	R	P	Y
880302020100	<i>Strongylura marina</i>	Atlantic needlefish	M	P	
885703130300	<i>Syacium papillosum</i>	Dusky flounder	M	D	Y
885802011600	<i>Symphurus atricauda</i>	California tonguefish	M	D	
876202010100	<i>Synodus foetens</i>	Inshore lizardfish	R	D	
885003040400	<i>Thunnus atlanticus</i>	Blackfin tuna	M	P	Y
875501070100	<i>Thymallus arcticus</i>	Arctic grayling	E	P	Y
883561400100	<i>Tilapia mossambica</i>	Mozambique tilapia	R	E	Y
883561040500	<i>Tilapia zillii</i>	Redbelly tilapia	R	E	Y
551525020100	<i>Tresus capax</i>	Horse clam	R	D	Y
870802090200	<i>Triakis semifasciata</i>	Leopard shark	M	E	Y
884701300100	<i>Tridentiger trigonocephalus</i>	Chameleon goby	R	D	
885801010100	<i>Trinectes maculatus</i>	Hogchoker	M	D	
880302030200	<i>Tylosurus crocodilus</i>	Houndfish	M	E	Y
875802010200	<i>Umbra limi</i>	Central mudminnow	R	E	
050601010000	<i>Vaucheria</i>	Macroalgae	?	E	

^aFish species is considered: R = resident, M = migratory, E = either resident or migratory, ? = unknown.

^bFish species is considered: D = demersal, P = pelagic, E = either, ? = unknown.

Appendix G

Notes on the Methodology for Evaluating Sediment Toxicity Tests

Results of sediment toxicity tests conducted around the United States were submitted with several databases for evaluation in the NSI. Additional processing of records was required for most of the data. Because test results were reported differently in each database, appropriate interpretation of the test results was sometimes confusing. This section explains how the toxicity test data were handled for the NSI evaluation with respect to issues related to sampling date, type of test, sample location identification, and results of control or reference tests conducted during the toxicity tests.

Sampling Date

Only those tests in the databases for which the sediment samples were obtained between January 1, 1980, and December 31, 1993, were evaluated. Tests before and after that period were eliminated.

Sample Location

Records were examined to determine whether the sampling station from which the sediment sample was collected had been identified by latitude and longitude coordinates. Samples that were not referenced to a specific location were not considered in this study. Tests from the Great Lakes Sediment Inventory (GLSI) database were not considered because sample locations were not appropriately identified. Sediment samples in the EPA Region 10/U.S. Army Corps of Engineers Seattle District's Sediment Inventory (SEACOE) from sampling stations located in British Columbia were also not considered in the analysis.

Type of Test

Data from seven databases (Table G-1) were reviewed to determine whether they had reported the results of sediment (solid-phase) and elutriate nonmicrobial toxicity tests in which the endpoint was mortality. Records pertaining to chronic toxicity tests, microbial toxicity tests, tests that were not conducted with sediment or elutriate, and tests in which the endpoint was not percent mortality (or percent survival, which could be converted to percent mortality) were excluded from further consideration.

Only the DMATS and GOM databases clearly reported the phase (solid, elutriate, particulate) of sediment sample used in the bioassays conducted; ODES provided this information for some of the tests. If the phase was not indicated, this information was obtained or best professional judgment was used to identify the phase used in the tests. For some tests, comparison of species with those used in standard EPA test protocols or with species used in other sediment toxicity tests in the databases permitted assignment of phase with certainty. Other species might be used in sediment-, elutriate-, and particulate-phase tests, and the phase was assigned with uncertainty. Table G-2 presents a list of species used in toxicity tests whose results are included in the NSI. Table G-2 also presents the type of toxicity test for which each species is generally used (i.e., liquid-phase, elutriate-phase, suspended particulate-phase, sediment/solid-phase). The data presented in Table G-2 are the basis for determining whether the toxicity test of concern was conducted using the solid or elutriate phase. A "Y" entered in Table G-2 indicates that the phase was given with the test results; an "E" indicates that the phase was estimated using best professional judgment based on the species used in the toxicity test.

Table G-1. Toxicity Test Database Characteristics

Database	Sample Locations Identified by Lat/Long	Type of Test	Laboratory Control Tests	Reference Sediment Tests	Comments
U.S. Army Corps of Engineers, Dredged Material Tracking System (DMATS)	Yes, all 74	Solid and Elutriate (identified in database)	Replicate control test results provided	Replicate reference sediments tested with each batch of sediment samples	Used means of reference sediment replicates in the evaluation (contact: Alan Ota, EPA Region 9)
EPA's Environmental Monitoring and Assessment Program, Louisianian Province (EMAP-LA)	Yes, all 259	Solid Phase (not identified in database, provided)	Not provided in D3 database, provided on request	No	Sediment sample test results were calculated from the additional data provided (contact: Kevin Summers, EPA/ERL/GB)
EPA's Environmental Monitoring and Assessment Program, Virginian Province (EMAP-VA)	Yes, all 179	Solid and Elutriate (not identified in database, provided)	Not provided in D3 database, provided on request	No	Sediment sample test results were calculated from the additional data provided (contact: Daryl Keith, EPA/ERL/N)
Gulf of Mexico Program's Contaminated Sediment Inventory (GOM)	Yes, all 42	Solid Phase (identified in database)	ERL-N: Yes USACE: No GCRL: No, provided on request	ERL-N: Yes USACE: Yes GCRL: No	Long Island Sound reference sediment was used to generate control data for tests done by ERL-N (contacts: Phil Crocker, EPA; John Scott, SAIC) and control data obtained for GCRL (contact: Julia Lyle, GCRL); for USACE tests used mean of the reference test results as control
EPA's Great Lakes Sediment Inventory (GLSI)	No	Not identified in database	Not provided in database	No?	Sample location IDs and control test results were not provided; therefore, these data were not evaluated for the NSI (contact: Bob Hoke, SAIC)
EPA's Ocean Data Evaluation System (ODES)	Only 18 out of 68	Solid Phase (not identified in database)	Yes	No	Used controls (contact: Tad Deschler, Tetra Tech)
EPA's Region 10/U.S. Army Corps of Engineers Seattle District's Sediment Inventory (SEACOE)	Only 18 out of 68	Solid Phase (not identified in database)	Yes, some had to be provided on request	Yes	Used controls (contact: Roberts Feins, Environmental Information Consultants; John Armstrong, EPA Region 10; and Gary Braun, Tetra Tech, for Puget Sound Estuary Program Reports, 1988)

Table G-2. Test Species Used in Sediment Bioassay Test Results Included in the NSI

Species Code	Species Name	Type of Toxicity Test							
		Liquid (L)	Elutriate (E)	Particulate (P)	Solid (S)	C (L most Common) (L or E)	D (L, E, or P)	A (L, E, P, or S)	Unknown
80509070600									E
615301010900	<i>Acanthomyxis costata</i>		Y		Y				
615301010400	<i>Acanthomyxis macropsis</i>	Y	Y		Y				
615301010700	<i>Acanthomyxis sculpta</i>	Y				E			
611829010000	<i>Acartia spp. spp.</i>	Y	Y						
616902010800	<i>Ampelisca abdita</i>				Y,E				
616800000000	<i>Amphipods</i>				Y				
610401010100	<i>Artemia salina</i>	Y	Y						
616302070900	<i>Asellus intermedius</i>				E				
650508331700	<i>Chironomus riparius</i>				E				
650508330100	<i>Chironomus tentans</i>				E				
885703010200	<i>Citharichthys stigmaceus</i>	Y			Y				
616915021500	<i>Corophium spinicorne</i>				Y,E				
617922010000	<i>Crangon spp. spp.</i>	Y	Y		Y				
551002010100	<i>Crassostrea gigas</i>		Y		Y			E	
551002010200	<i>Crassostrea virginica</i>				Y				
880404010100	<i>Cyprinodon variegatus</i>	Y		Y					
610902010900	<i>Daphnia magna</i>					E			
610902010100	<i>Daphnia pulex</i>					E			
815501010100	<i>Dendroaster excentricus</i>					E			

Table G-2. (Continued)

Species Name	Species Name	Type of Toxicity Test							
		Liquid (L)	Elutriate (E)	Particulate (P)	Solid (S)	C (L most Common) (L or E)	D (L, E, or P)	A (L, E, P, or S)	Unknown
880404020700	<i>Fundulus grandis</i>	Y		Y					
881810101000	<i>Gasterosteus aculeatus</i>					E			
616915090200	<i>Grandidierella japonica</i>				Y				
622003030700	<i>Hexagenia limbata</i>				E				
615301010700	<i>Holmesimysis sculpta</i>	Y	Y		Y	E			
616923040100	<i>Hyalella azteca</i>				E				
500501010300	<i>Lambriculus variegatus</i>				E				
814802010200	<i>Lytechinus pictus</i>	Y	Y						
551531011600	<i>Macoma balthica</i>				E				
551531011400	<i>Macoma nasuta</i>		Y		Y,E				
551531010000	<i>Macoma</i> spp.				E				
615303140600	<i>Metamysidopsis elongata</i>	Y	Y		Y				
651530100000	<i>Mysid shrimp</i>	Y		Y	Y				
615301210200	<i>Mysidopsis bahia</i>			Y	Y				
550701010100	<i>Mytilus edulis</i>	Y	Y					E	
500124030500	<i>Neanthes arenaceodentata</i>				Y,E				
500124030000	<i>Neanthes</i> spp.				E				
500125011900	<i>Nephtys caecoides</i>				Y,E				
500124030200	<i>Nereis virens</i>				Y				
551706040100	<i>Panopea generosa</i>				E				

Table G-2. (Continued)

Species Code	Species Name	Type of Toxicity Test							
		Liquid (L)	Elutriate (E)	Particulate (P)	Solid (S)	C (L most Common) (L or E)	D (L, E, or P)	A (L, E, P, or S)	Unknown
	<i>Paratanytarsus parthogenetic</i>				E				
617701010200	<i>Panaeus duorarum</i>				Y				
MICROTOX	<i>Photobacterium phosphoreum</i>					E			
877601160200	<i>Pimephales promeles</i>	Y				E			
551547070100	<i>Protothaca staminea</i>				Y				
616942150400	<i>Rhepoxynius abronius</i>				Y, E				
080309070600	<i>Selenastrum capricornutum</i>								E
814903020400	<i>Strongylocentrotus purpuratus</i>	Y	Y			E			
611910030100	<i>Tigriopus californicus</i>								E

Only DMATS contained elutriate test results in addition to sediment test results; all other tests evaluated were sediment (solid-phase) test results.

Test Controls

Toxicity data were screened to determine whether control data were reported. Sediment toxicity test laboratory or performance controls are usually clean sand or sediment run under the same conditions in which the same test organisms are exposed at the same time as those exposed to the sediment samples tested. Controls are used to determine whether observed mortality might be the result of the quality of test organisms used or other factors, and not the result of exposure to possible toxics in the sediment samples.

The databases were screened to locate control test data for each sediment sample tested. The GLSI database did not contain any control test data; because of this, as well as the lack of station-identifying coordinates, the GLSI database was eliminated from evaluation for the NSI. For the other databases, control test results were matched to the sediment test results and were treated as follows:

- Multiple control and reference sample test results were reported for each sediment tested in the DMATS database. These were determined to be replicate test results. Because the sediment samples tested in DMATS were usually fine-grained and the laboratory performance controls were sand, the reference sediment samples were used as "controls" to evaluate toxicity of sediment samples. The percent mortality for the reference replicates were averaged for each reference site to obtain the mean percent mortality for the reference sediment for comparison with the sediment sample test result.
- The D3 version of both the EMAP-LA and EMAP-VA databases contained control-corrected results for the sediment samples tested. The control-corrected results were obtained using the following equation:

$$\frac{\text{percent survival of organisms in sediment sample test}}{\text{percent survival of organisms in control test}} = \text{control-corrected percent survival}$$

- EMAP-LA provided a revised database on request that contained the percent survival of the controls. The sediment sample test results were calculated according to this equation:

$$\text{percent survival of organisms in sediment sample test} = \frac{\text{control-corrected percent survival} \times \text{percent survival of organisms in control test}}{100}$$

- EMAP-VA provided a revised database on request that contained the mean percent mortality of controls and the mean percent mortality of the sediment sample tests for each station, as well as the control-corrected percent survival.
- The GOM database reported control test results for tests conducted by EPA's Environmental Research Laboratory in Narragansett. A low-salinity control test performed at the same time was not used in the evaluation. The single reference sediment sample was treated as a sediment toxicity test result. No control tests were available from the USACE data set within this database; the mean of reference sediment toxicity test results was used as the "control" for these test data. No control test results were found in the GOM database for the GCRL data set. Total percent mortality of pooled control test replicates were provided by Julia Lytle of GCRL and entered into the database for the NSI analysis.
- The ODES database reported single-value control results for the ARSR and OSE data sets. (Whether these were means of replicate tests is unknown.) One sediment test result in ARSR was matched to two different control test results; however, the one control test result that was not matched elsewhere in the data set was eliminated for the analysis.

- The SEACOE database contained single-value control test results for the ALCTRAZ data set and several series of control test results for other data sets (e.g., EVCHEM and EBCHEM). Information on the correct control series was obtained, and the proper control test results were evaluated in the computer program. Means were calculated for replicates in the series and used to evaluate the sediment sample test results.

Results of control tests reported as "percent survival" were converted to "percent mortality" by the following calculations:

$$\text{percent mortality} = 100 - \text{percent survival}$$

$$\text{percent mortality} = \text{number of surviving organisms} / \text{total number of organisms in test}$$

Sometimes entries in databases reversed "mortality" and "survival" (e.g., PSE data set in the ODES database). Any questions concerning the designation were checked and corrected if necessary. If replicate sediment toxicity test results were provided for a sampling site in the database, a mean was calculated and compared to the mean control mortality. (Some databases provided only the means, e.g., EMAP-LA, EMAP-VA.) For the purpose of the NSI evaluation, if the control had greater than 20 percent mortality (less than 80 percent survival), that test was excluded from further consideration.

Reference Sediment Stations

Some data sets included data for reference sediments that were run simultaneously with the control and sediment samples. Reference sediment is sediment collected from a field site that is appreciably free of toxic chemical contaminants and has grain size, total organic carbon, sulfide and ammonia levels, and other characteristics similar to the sediment samples to be tested for toxicity. Because reference sediments should match the characteristics of the sediment samples more closely than the sand or sediment used for the laboratory (performance) control, they should provide information on the appropriateness of using a particular test organism since the suitability and survival of different species can be affected by these other physical and chemical characteristics of the sediment.

- As noted previously, DMATS provided several reference sediment samples for each toxicity test, along with control test results. The number of such reference sediment samples varied for different test dates, and these sediment samples were determined to represent replicates. The average percent mortality was determined from each set of replicates and this was used as a "control" to evaluate the toxicity of sediment samples in this database. If percent mortality of the mean reference test result exceeded 20 percent, the sediment toxicity tests that were run with that reference sediment were not used in the evaluation.
- Reference sediment test results were not identified in the EMAP-LA, EMAP-VA, or ODES databases.
- In the GOM database, a reference sediment test was run in tests conducted by EPA's Environmental Research Laboratory in Narragansett. This single reference sediment sample was treated as a sediment toxicity test result. Reference sediment tests in the USACE data set were averaged and used as the control for analysis since other control test data were not provided in the data set.
- Reference sediment toxicity test results in the SEACOE database were treated as a sample site.

Because reference toxicity test results were not available for all of the sediment toxicity tests, reference sediment sample test results were not used as "controls" in the evaluation of sediment toxicity test data in the NSI, with the exception of the DMATS data and the USACE data in the GOM database. The remaining reference sediment test results were compared with the control results to determine whether significant toxicity was indicated at that field site; i.e., they were treated like a sediment toxicity test result (see below).

It should be noted, however, that careful examination of such reference test results could improve the interpretation of sediment toxicity tests; i.e., they might indicate that test organisms were adversely affected by sediment characteristics, not by toxic chemicals. Thus, the classification of some sites using the sediment toxicity tests might

be inappropriate because the control test result did not adequately explain the result, based on the test organism's health or sensitivity to test conditions.

Test Results

For the NSI evaluation protocol for sediment toxicity test data, significant toxicity was indicated if there was a difference of 20 percent survival from control survival (e.g., if control survival was 100 percent and 80 percent or less of the test organisms survived, or if control survival was 80 percent and 60 percent or less of the test organisms survived, significant toxicity was indicated). Although a number of different test species and protocols were used in the tests evaluated, this threshold provides a preliminary indication of sediment toxicity for classifying sampling stations for the NSI.

Appendix H

Additional Analyses for PCBs and Mercury

To perform the screening analysis for the National Sediment Quality Survey using NSI data, EPA selected reasonably conservative screening values, including theoretically and empirically derived risk-based screening levels. The limited number of sediment criteria available for use in this type of evaluation, however, contributed to the possibility of over- and underestimation of potential adverse effects associated with sediment contaminated for some chemicals. Two chemicals where this issue is particularly relevant are PCBs and mercury. EPA conducted further analyses on PCBs and mercury to determine the effect of using different assessment parameters on the number of sampling stations where these chemicals were identified as associated with a probability of adverse effects.

Because of the tendency for PCBs to bind to sediment and because of the relative toxicity of these chemicals to humans, EPA selected a precautionary approach for the analysis of PCBs in the NSI evaluation. The approach was precautionary because (1) it did not require matching sediment chemistry data and tissue residue data for Tier 1 classification and (2) it used the cancer risk level of 10^{-5} for all congener, aroclor, or total PCB measurements to evaluate human health effects related to PCB contamination. EPA applied the cancer slope factor for aroclor 1260, the most potent commercial mixture, to all measures. It should be noted that there were only 542 sampling stations where matching sediment chemistry data and tissue residue data were available for analysis. In the following evaluation, the amount of PCB sediment and fish tissue data exceeding screening values other than those used in the NSI analysis is compared to the number of sampling stations classified as Tier 1 or Tier 2.

Figure H-1 is a cumulative density function graph depicting the maximum PCB concentration at each sediment sampling station where PCBs were detected. The various screening values that could be used to indicate adverse effects levels

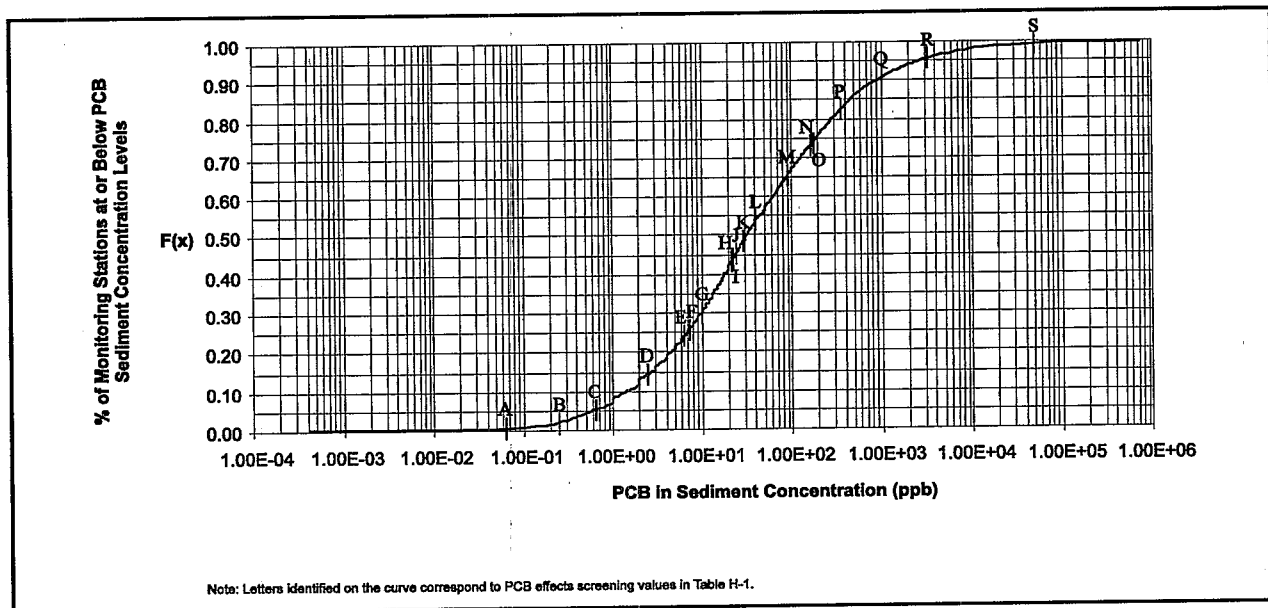

Figure H-1. Cumulative Frequency Distribution of PCB Sediment Concentration Data (All Aroclors and Total PCB).

of PCBs in sediment are plotted as A through S in the figure and described in Table H-1. The top two sections of Table H-1 present the screening values of PCBs in sediment that are protective of human or wildlife consumers. The levels shown were derived using the theoretical bioaccumulative potential (TBP) analysis with the default lipid content (3 percent), default organic carbon content (1 percent), and BSAFs with and without the safety factor of 4. (See Appendices B and C for further explanation.) Depending on the screening value, the number of sediment chemistry sampling stations with detectable PCBs exhibiting potential human health or aquatic life effects varies from under 1 percent to over 99 percent. The screening values selected for the NSI evaluation classify approximately 85 percent of sediment chemistry sampling stations in Tier 2 for human health effects (Point D). For aquatic life effects, the selected screening values classify 25 percent of sampling stations as Tier 1 (Point O) and 57 percent of sampling stations as Tier 2 (Point H).

Table H-1. Sediment Sampling Stations with Detectable Levels of PCBs That Exceed Various Screening Values^{a,b}

Type of Screening Value	Associated Level (ppb)	Level Plotted in Figure H-1 Corresponds to Letter	Number of Stations with Detected PCBs Exceeding Level	Percentage of Stations with Detected PCBs Exceeding Level
Protection of Consumers				
Cancer Risk Level				
10 ⁻⁶	0.25	B	3,772	98.2
10 ^{-5d}	2.5	D	3,290	85.6
10 ⁻⁴	25	J	2,076	54.0
Noncancer Hazard Quotient of 1	40	L	1,761	45.8
FDA Tolerance Level	360	P	652	17.0
Wildlife Criteria	29	K	1,977	51.5
Protection of Consumers Using BSAF with Safety Factor^c				
Cancer Risk Level				
10 ⁻⁶	0.063	A	3,828	99.6
10 ⁻⁵	0.63	C	3,648	95.0
10 ⁻⁴	6.3	E	2,921	76.0
Noncancer Hazard Quotient of 1	9.9	G	2,699	70.2
FDA Tolerance Level	90	M	1,330	34.6
Wildlife Criteria	7.2	F	2,849	74.2
Protection of Aquatic Life				
ER-L	22.7	I	2,150	56.0
ER-M	180	N	976	25.4
AET-L	1,000	Q	353	9.2
AET-H	3,100	R	165	4.3
TEL ^e	21.6	H	2,182	56.8
PEL ^f	189	O	962	25.0
Other Protection Levels				
TSCA ^g Level	50,000	S	21	0.55

^aMaximum total or arochlor-specific value at a given station was used.

^bPCBs were detected at 3,842 (41%) of the 9,401 stations where collected samples were analyzed for them.

^cFor this presentation, measured levels were compared to risk levels using a default organic carbon content (1%) and default organism lipid content (3%). Use of site-specific organic carbon would yield slightly different results.

^dLevels used in the current National Sediment Quality Survey evaluation for human health.

^eLevels used in the current National Sediment Quality Survey evaluation for aquatic life (Tier 2).

^fLevels used in the current National Sediment Quality Survey evaluation for aquatic life (Tier 1).

^gToxic Substances Control Act. 40 CFR Part 761, Subpart B, § 761.20.

Figure H-2 and Table H-2 present the comparison of different screening values and the corresponding number of fish tissue sampling stations with detected levels of PCBs exceeding the screening values. The 10^{-5} cancer risk level (Point B) was one of the most conservative thresholds: concentrations exceeded this level at approximately 95 percent of tissue residue sampling stations where PCBs were detected. These sampling stations were classified as Tier 1 for potential human health risk.

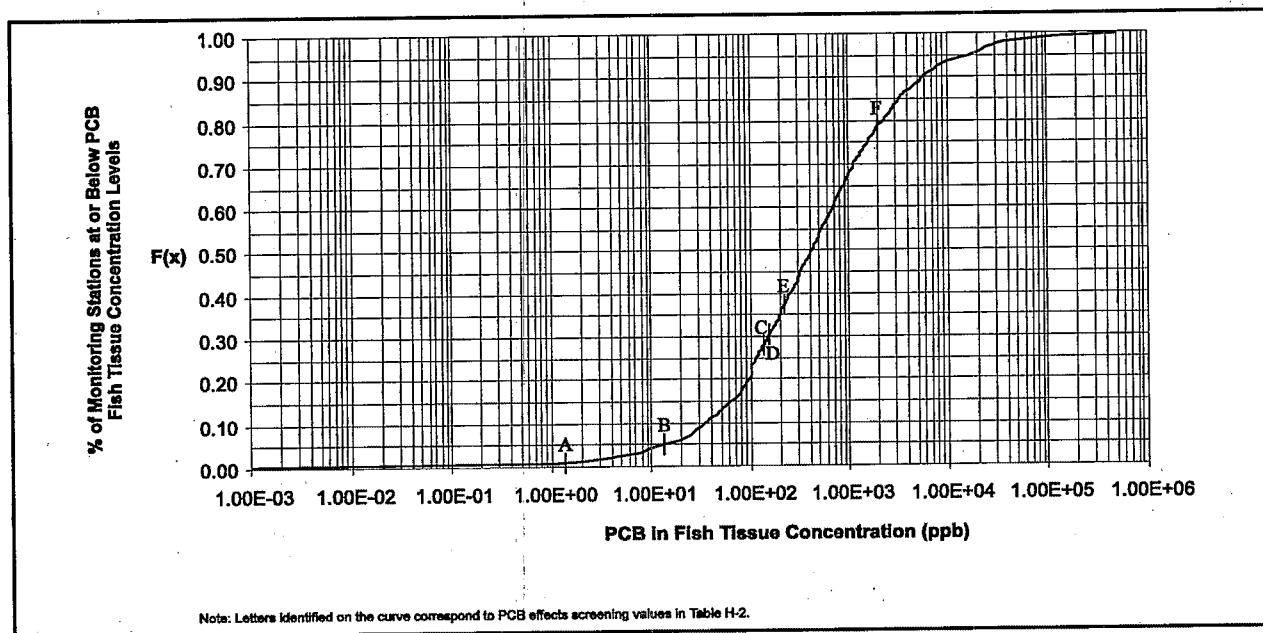

Figure H-2. Cumulative Frequency Distribution of PCB Fish Tissue Concentration Data (All Aroclors and Total PCB).

Table H-2. Fish Tissue Sampling Stations with Detectable Levels of PCBs in Demersal, Resident, Edible Fish That Exceed Various Screening Values^{a,b}.

Type of Screening Value	Associated Level (ppb)	Level Plotted in Figure H-2 Corresponds to Letter	Number of Stations with Detected PCBs Exceeding Level	Percentage of Stations with Detected PCBs Exceeding Level
Protection of Consumers				
Cancer Risk Level				
	10 ⁻⁶	A	2,354	99.3
	10 ⁻⁵ ^c	B	2,256	95.2
	10 ⁻⁴	C	1,686	71.1
Noncancer Hazard Quotient of 1	220	E	1,473	62.2
FDA Tolerance Level	2,000	F	489	20.6
Wildlife Criteria	160	D	1,620	68.4

^aMaximum total or aroclor-specific value at a given station was used.

^bPCBs were detected at 2,370 (73%) of the 3,234 stations where collected samples were analyzed for them.

^cLevels used in the current National Sediment Quality Survey evaluation for human health.

In contrast to the PCB evaluation, the evaluation of mercury detected in fish tissue residue in the NSI analysis was substantially less conservative than that which would result from use of different screening values. To determine the possible outcomes of different data evaluations, EPA performed additional analyses of mercury fish tissue data included in the NSI. Figure H-3 and Table H-3 present six screening values that could be applied for the protection of consumers ingesting mercury-contaminated fish. As shown in these displays, both EPA's current noncancer reference dose recommended for general use (Point E) and the FDA action level (Point D), the screening value used in the current NSI analysis, result in only about 4 percent of sampling stations with detectable levels classified as posing potential risk to human health.

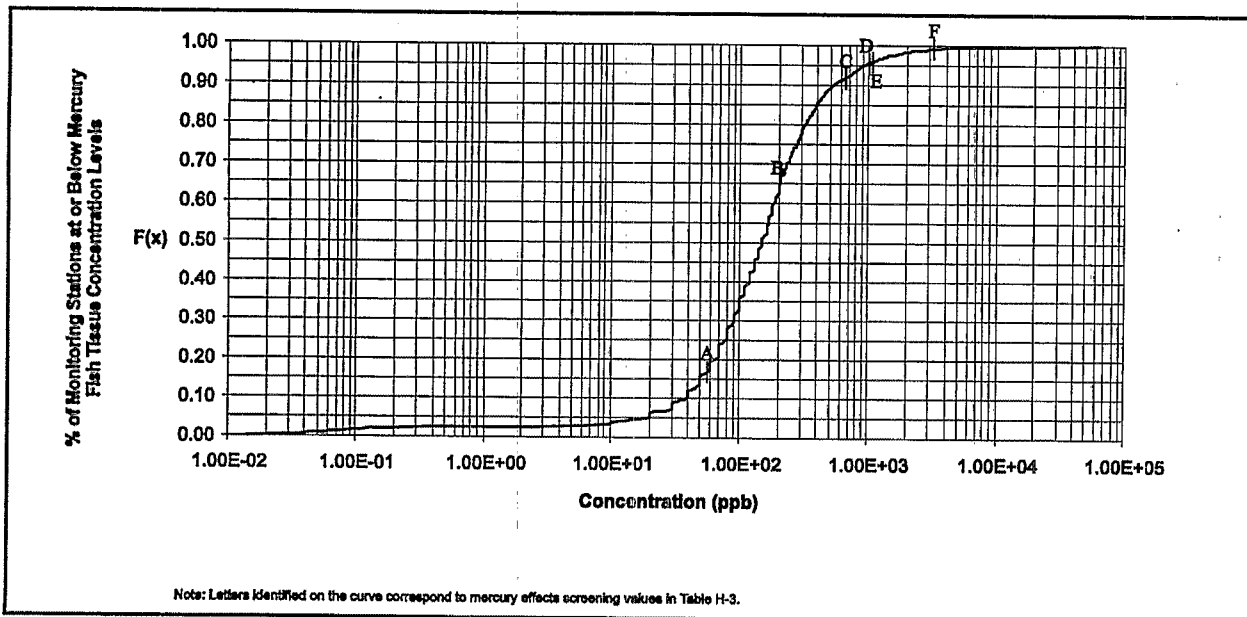

Figure H-3. Cumulative Frequency Distribution of Mercury Fish Tissue Data for Demersal, Resident, and Edible Species.

Table H-3. Fish Tissue Sampling Stations with Detectable Levels of Mercury in Demersal, Resident, Edible Fish Species That Exceed Various Screening Values^{a,b}

Type of Screening Value	Associated Level (ppb)	Level Plotted in Figure H-3 Corresponds to Letter	Number of Stations with Detected Mercury Exceeding Level	Percentage of Stations with Detected Mercury Exceeding Level
Protection of Consumers				
Canadian Guideline ^b	200	B	908	35.1
Noncancer Hazard Quotient of 1 (1995) ^c	1,100	E	91	3.5
Noncancer Hazard Quotient of 1 (pre-1995) ^d	3,231	F	15	0.6
Noncancer Hazard Quotient of 1 (pre-1995 for infants) ^e	646	C	204	7.9
FDA Action Level ^f	1,000	D	103	4.0
Wildlife Criteria ^g	57.3	A	2,150	83.0

^aMercury was detected at 2,589 (90%) of the 2,861 stations where collected samples were analyzed for mercury.

^bCanadian guideline limit for mercury in fish that are part of a subsistence diet (Health and Welfare Canada, 1979).

^cMethyl mercury reference dose that was available in IRIS in 1995 (1×10^{-4} mg/kg-day).

^dCorresponds to mercury reference dose available in IRIS prior to 1995 (3×10^{-4} mg/kg-day).

^eCorresponds to mercury reference dose available in IRIS prior to 1995 divided by a factor of 5 to protect against developmental effects among infants (6×10^{-5} mg/kg-day). This value was formerly used by the EPA Office of Water.

^fLevel used in the current National Sediment Quality Survey evaluation for human health.

^gThe results of the wildlife analysis shown in Table 3-5 are slightly different because the data set used for that analysis included demersal, resident species (could be considered edible or not).

The NSI evaluation restricted the data analyzed to demersal, resident, and edible species. Figure H-4 and Table H-4 present the same six mercury screening values with the data for all fish species considered edible by humans with detectable levels of mercury in the NSI. If all edible fish species were analyzed using selected screening values, 9 percent of sampling stations would be classified as Tier 2 because of mercury contamination (Point D). However, the proportion of sampling stations with detectable levels of mercury that exceed some other human health levels ranges from 20 percent to over 55 percent of sampling stations.

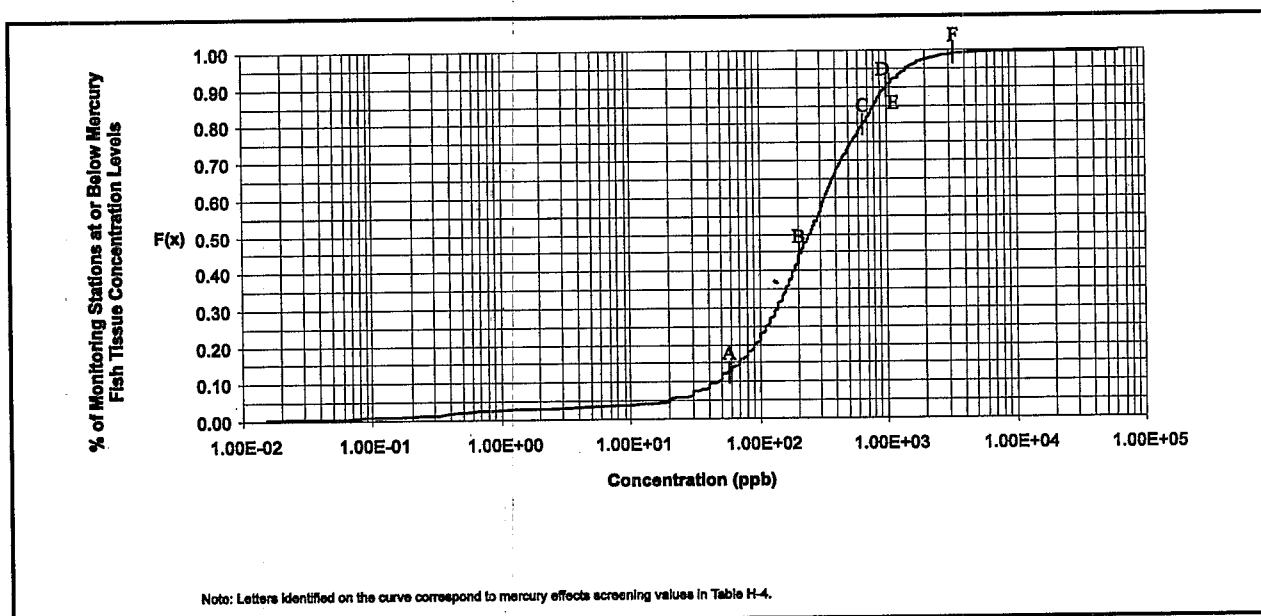

Figure H-4. Cumulative Frequency Distribution of Mercury Fish Tissue Data for All Edible Species.

Table H-4. Fish Tissue Sampling Stations with Detectable Levels of Mercury in Edible Fish Species That Exceed Various Screening Values^{a,b}

Type of Screening Value	Associated Level (ppb)	Level Plotted in Figure H-4 Corresponds to Letter	Number of Stations with Detected Mercury Exceeding Level	Percentage of Stations with Detected Mercury Exceeding Level
Protection of Consumers				
Canadian Guideline ^b	200	B	2,308	55.8
Noncancer Hazard Quotient of 1 (1995) ^c	1,100	E	353	7.8
Noncancer Hazard Quotient of 1 (pre-1995) ^d	3,231	F	37	0.9
Noncancer Hazard Quotient of 1 (pre-1995 for infants) ^e	646	C	821	19.9
FDA Action Level ^f	1,000	D	374	9.0
Wildlife Criteria ^g	57.3	A	3,623	87.6

^aMercury was detected at 4,135 (93%) of the 4,426 stations where collected samples were analyzed for mercury.

^bCanadian guideline limit for mercury in fish that are part of a subsistence diet (Health and Welfare Canada, 1979).

^cMethyl mercury reference dose that was available in IRIS in 1995 (1×10^{-4} mg/kg-day).

^dCorresponds to mercury reference dose available in IRIS prior to 1995 (3×10^{-4} mg/kg-day).

^eCorresponds to mercury reference dose available in IRIS prior to 1995 divided by a factor of 5 to protect against developmental effects among infants (6×10^{-5} mg/kg-day). This value was formerly used by the EPA Office of Water.

^fLevel used in the current National Sediment Quality Survey evaluation for human health.

^gThe results of the wildlife analysis shown in Table 3-5 are slightly different because the data set used for that analysis included demersal, resident species (could be considered edible or not).

Appendix I

NSI Data Evaluation Approach Recommended at the National Sediment Inventory Workshop, April 26-27, 1994

The original proposed approach for the integration and evaluation of NSI sediment chemistry and biological data was developed at the Second National Sediment Inventory Workshop held on April 26 and 27, 1994, in Washington, D.C. The proposed workshop approach was modified, however, to address inconsistencies found in trying to implement the approach and to address the concerns of the many experts in the field of sediment quality assessment who commented on the workshop approach. This appendix presents the NSI data evaluation approach developed by the April 1994 workshop participants. The actual approach that EPA used in the NSI data evaluation is presented in Chapter 2. A list of workshop participants is provided at the end of this appendix.

Using the approach recommended by workshop participants, sediment sampling stations could be placed into one of the following five categories based on an evaluation of data compiled for the NSI:

- High probability of adverse effects to aquatic life or human health
- Medium-high probability of adverse effects to aquatic life or human health
- Medium-low probability of adverse effects to aquatic life
- Low probability of adverse effects to aquatic life or human health
- Unknown probability of adverse effects to aquatic life or human health.

Using the workshop approach, contaminated sediment sampling stations could be placed into one of the five categories based on an evaluation of the following types and combinations of data:

- Sediment chemistry data alone
- Toxicity data alone
- Tissue residue data alone
- Sediment chemistry and tissue residue data
- Sediment chemistry and histopathological data
- Sediment chemistry, sediment toxicity, and tissue residue data.

The overall approach developed by workshop participants is summarized in Table I-1 and is described below.

High Probability of Adverse Effects to Aquatic Life or Human Health

Based on the evaluation approach proposed by the April 1994 workshop participants, a sampling station could be classified as having a high probability of adverse effects to aquatic organisms or human health based on sediment chemistry data alone, toxicity data alone, tissue residue data alone, or a combination of sediment chemistry and tissue residue or histopathological data.

Table I-1. Original Approach Recommended by NSI Workshop (April 1994)

Category of Sampling Station Classifications	Data Used to Determine Classifications				
	Sediment Chemistry (sampling station is identified by any one of the following characteristics)		Tissue Residue/Histopathology	Toxicity	
High Probability of Adverse Effects to Aquatic Life or Human Health	Sediment chemistry values exceed sediment draft quality criteria for any one of the five chemicals for which criteria have been developed by EPA (based on measured TOC)	OR	Human health thresholds for dioxin or PCBs are exceeded in resident species (not a consensus agreement—participants evenly divided on this issue)	OR	Toxicity demonstrated by two or more acute toxicity tests (one of which must be a solid-phase nonmicrobial test)
	OR				
	Sediment chemistry values exceed all relevant AETs (high), ERMs, PELs, and SQALs for any one chemical (can use default TOC)				
	OR	AND	Tissue levels in resident species exceed FDA action levels or EPA risk levels, or wildlife criteria	—	—
	Sediment chemistry values >50 ppm for PCBs				
OR	AND	Presence of fish tumors	—	—	
OR	AND	Tissue levels in resident species exceed FDA action levels or wildlife criteria	OR	Toxicity demonstrated by a single-species toxicity test (solid-phase, nonmicrobial)	
Medium-High Probability of Adverse Effects to Aquatic Life or Human Health	Sediment chemistry values exceed at least two of the sediment upper screening values (i.e., ERM, SQAL, PEL, high AET) (can use default TOC)	OR	Tissue levels in resident species are lower than FDA action levels or wildlife criteria	AND	No toxicity demonstrated in tests using at least two species and at least one solid-phase test using amphipods
	OR				
OR	Sediment chemistry TBP exceeds FDA action levels or wildlife criteria	OR	—	—	Toxicity demonstrated by a single species toxicity test (elutriate-phase, nonmicrobial)
Medium-Low Probability of Adverse Effects to Aquatic Life	Sediment chemistry values exceed one of the lower screening values (ERL, SQAL, TEL, lower AET) (can use default TOC and AVS)	OR	—	—	Toxicity demonstrated by a single species toxicity test (elutriate-phase, nonmicrobial)
Low Probability of Adverse Effects to Aquatic Life or Human Health	No exceedance of lower screening values	AND	Tissue levels in resident species are lower than FDA action levels or wildlife criteria	AND	No toxicity demonstrated in tests using at least two species and at least one solid-phase test using amphipods
	AND				
OR	No sediment chemistry TBP exceedances of FDA action levels or wildlife criteria	AND	—	—	—
Unknown	Not enough data to place a site in any of the other categories.				

For a sampling station to be classified as one with a high probability of adverse effects based on sediment chemistry data alone, at least one of three criteria must be met: (1) sediment chemistry values exceed the sediment quality criteria (SQC) developed by EPA for acenaphthene, dieldrin, endrin, fluoranthene, or phenanthrene; (2) sediment chemistry values exceed all appropriate screening values for a given chemical (i.e., high apparent effects thresholds (AETs), effects range-medians (ERMs), probable effects levels (PELs), and sediment quality advisory levels (SQALs)); and/or (3) sediment chemistry values exceed 50 ppm for polychlorinated biphenols (PCBs). When comparing sediment chemistry values to the SQCs, measured total organic carbon (TOC) must be used. Workshop participants suggested using default TOC values in the comparison of sediment chemistry values to SQALs if actual measured TOC values are not available. However, if default TOC values are used in a comparison of sediment chemistry measurements to SQCs, the highest that a sampling station could be classified would be medium-high potential for adverse effects.

For a sampling station to be classified as having a high probability of adverse effects based on a combination of sediment chemistry and tissue residue data, sediment chemistry theoretical bioaccumulation potential (TBP) and tissue levels in resident, nonmigratory species must exceed FDA tolerance/action/guidance levels, EPA risk levels, or EPA wildlife criteria. Workshop participants also recommended that a sampling station be classified as having a high probability of adverse effects if fish tumors are present in resident species and elevated sediment chemistry concentrations for polynuclear aromatic hydrocarbons (PAHs) are present.

The workshop participants were evenly divided on whether a sampling station could be classified as having a high probability of adverse effects based solely on the exceedance of human health screening values for dioxins or PCBs in resident fish species. Participants did agree that benthic community data in combination with sediment chemistry data could be used in the future, but not for the current evaluation, to classify sediment sampling station. Methods are currently not adequate to establish a direct causal relationship between benthic community changes and sediment contamination at specific sampling stations without additional data.

For a sampling station to be classified as having a high probability of adverse effects based on toxicity data alone, toxicity must be demonstrated by two or more acute toxicity tests, at least one of which must be a solid-phase, nonmicrobial test.

Medium-High Probability of Adverse Effects to Aquatic Life or Human Health

Workshop participants suggested that a sampling station could be classified as having a medium-high probability of adverse effects on aquatic life or human health based on sediment chemistry data alone, toxicity data alone, or tissue residue data alone.

For a sampling station to be classified as having a medium-high probability of adverse effects based on sediment chemistry data alone, the station must meet at least one of two criteria: (1) sediment chemistry values exceed at least two of the sediment chemistry upper screening values (i.e., appropriate ERMs, SQALs, PELs, or AET-highs) or (2) sediment chemistry TBP values exceed FDA tolerance/action/guidance levels or EPA wildlife criteria. In the comparison of sediment chemistry values to SQALs, default TOC values can be used.

A sampling station could also be classified as having a medium-high probability of adverse effects if toxicity is demonstrated by a single-species, nonmicrobial toxicity test using the solid phase as the testing medium or if actual fish tissue residue levels exceed FDA tolerance/action/guidance levels or EPA wildlife criteria.

Medium-Low Probability of Adverse Effects to Aquatic Life

Workshop participants suggested that a sampling station could be classified as having a medium-low probability of adverse effects to aquatic life based on either sediment chemistry data alone or toxicity data alone. A sampling station could be classified as having a medium-low probability of adverse effects if sediment chemistry values exceed at least one of the lower sediment chemistry screening values (i.e., ERL, TEL, SQAL, or AET-low). Workshop participants suggested that default TOC and AVS values could be used. To classify a sampling station as having a medium-low probability of adverse effects, toxicity would be demonstrated by a single-species, nonmicrobial toxicity

test using the elutriate phase as the test medium. Workshop participants did not propose any human-health-related criteria for placing a sampling station in the medium-low probability of adverse effects category.

Low Probability of Adverse Effects to Aquatic Life and Human Health

Using the workshop approach, for a sampling station to be classified as having a low probability of adverse effects on aquatic life and human health, all of the following criteria must be met: (1) there are no exceedances of the lower sediment chemistry screening values (i.e., ERL, TEL, SQAL, or AET-low); (2) there is no toxicity demonstrated in tests using at least two species and at least one solid-phase test using amphipods; (3) there are no TBP exceedances of FDA tolerance/action/guidance levels and EPA wildlife criteria; and (4) tissue levels of resident species are below FDA levels and EPA wildlife criteria.

Unknown Probability of Adverse Effects

Sampling station of unknown probability for causing adverse effects are those stations for which there are not enough data to place them in any of the other categories. Sediments at the sampling stations might or might not cause adverse impacts to aquatic life or human health.

Modifications to Workshop Approach

The approach for evaluating NSI data recommended by the April 1994 workshop participants provides the framework for the final evaluation approach actually used to evaluate the NSI data. Workshop participants had less than 4 hours to reach consensus on their recommendations for the approach following a day and a half of debate covering many challenging issues. As a result, some of the specific issues concerning how data were to be evaluated to place sampling stations into the five categories remained unresolved. For example, "elevated sediment chemistry concentrations of PAHs" together with the presence of fish tumors is one criterion for placing a sampling station in the high probability of adverse effects category. However, how "elevated" do sediment chemistry concentrations of PAHs have to be to meet this criterion? As another example, sediment chemistry values that exceed all relevant AETs, ERMs, PELs, and SQAL values for any one chemical are sufficient to place a sampling station in the high probability category, and exceedance of any two of these values is sufficient to place a sampling station in the medium-high probability category. But what if there are only two relevant screening values for comparison for a given contaminant? Does a sampling station at which both values are exceeded for a given chemical belong in the high or medium-high probability category?

A significant modification in the final approach used to evaluate the NSI data was the reduction in the number of categories from five to three, eventually combining the medium-high and medium-low categories and the low and unknown categories proposed in the workshop approach. In addition, the following evaluation parameters were dropped from the final approach:

- Sediment chemistry values > 50 ppm for PCBs
 - Expert reviewers of the methodology believed that this parameter was not necessary; i.e., a sampling station that was targeted as a higher probability for adverse effects by this parameter would already have been targeted at a much lower concentration using other parameters.
- Elevated sediment chemistry concentrations of PAHs and presence of fish tumors
 - Available fish liver histopathology data in the NSI are very limited; therefore, this evaluation parameter was not considered further.

In the final approach adopted for the evaluation of the NSI data, the EPA wildlife criteria were not included in the TBP and fish tissue residue parameters. Reviewers of the methodology felt that the wildlife criteria values were overly conservative for this screening assessment and thus could not be used to distinguish potentially highly contaminated sampling stations from only slightly contaminated station. A separate analysis of wildlife criteria was, however, conducted.

Workshop Participants

Sid Abel
 EPA/OPPT (7406)
 401 M Street, SW
 Washington, DC 20460
 (202) 260-3920; Fax (202) 260-0981

Jim Andreasen
 EPA ORD-EMAP (8205)
 401 M. Street, SW
 Washington, DC 20460
 (202) 260-5259; Fax (202) 260-4346

Gary Ankley
 EPA ERL-Duluth
 6201 Congdon Blvd.
 Duluth, MN 55804
 (218) 720-5603

Tom Armitage
 EPA/OST (4305)
 401 M Street, SW
 Washington, DC 20460
 (202) 260-5388

Bev Baker
 EPA/OST (4305)
 401 M Street, SW
 Washington, DC 20460
 (202) 260-7037

Rich Batiuk
 EPA Chesapeake Bay Program Office
 410 Severn Ave.
 Annapolis, MD 21403
 (410) 267-5731; Fax (410) 267-5777

Paul Baumann
 National Biological Survey
 Ohio State University
 2021 Coffey Rd.
 Columbus, OH 43210
 (614) 469-5701

Candy Brassard
 EPA/OPP
 7507C
 410 M Street, SW
 Washington, DC 20460
 (703) 305-5398

Barry Burgan
 EPA/OWOW (4503F)
 401 M Street, SW
 Washington, DC 20460
 (202) 260-7060

Allen Burton
 Biological Science Department F3301
 Wright State University
 Dayton, OH 45435
 (513) 873-2201

Scott Carr
 National Biological Survey
 NFCR Field Research Station
 TAMU-CC, Campus Box 315
 6300 Ocean Dr.
 Corpus Christi, TX 78412
 (512) 888-3366; Fax (512) 888-3443

Charlie Chandler
 USFWS/DEC
 4401 N. Fairfax Dr., Suite 330
 Arlington, VA 22203
 (703) 358-2148; Fax (703) 358-1800

Peter Chapman
 EVS Consultants
 195 Pemberton Ave.
 N. Vancouver, BC
 Canada V7P2R4
 (604) 986-4331

Tom Chase
 EPA/OWOW (4504F)
 401 M Street, SW
 Washington, DC 20460
 (202) 260-1909; Fax (202) 260-9960
 email: chase.tom@epamail.epa.gov

Greg Currey
 EPA/OWEC (4203)
 401 M Street, SW
 Washington, DC 20460
 (202) 260-1718

Kostas Daskalakis
 NOAA/ORCA 21
 1305 East Hwy.
 Silver Spring, MD 20910
 (301) 713-3028

Dom DiToro
 Manhattan College
 Environmental Engineering
 Bronx, NY 10471
 (718) 920-0276; Fax (718) 543-7914

Bob Engler
 COE-WES
 3909 Halls Ferry Road
 Vicksburg, MS 39180-6199
 (601) 634-3624

Jay Fields
 NOAA/HAZMAT
 7600 Sand Point Way, NE
 Seattle, WA 98115
 (206) 526-6404

Catherine Fox
 EPA/OST (4305)
 401 M Street, SW
 Washington, DC 20460
 (202) 260-1327; Fax (202) 260-9830

Tom Fredette
 COE New England District
 424 Trapels Rd.
 Waltham, MA 02254
 (617) 647-8291; Fax (617) 647-8303

Marilyn Gower
 EPA Region 3
 2530 Riva Rd., Suite 300
 Annapolis, MD 21401
 (410) 224-0942

Dave Hansen
 EPA ERL-Narragansett
 27 Tarzwell Dr.
 Narragansett, RI 02882
 (401) 782-3027; Fax (401) 782-3030

Jon Harcum
 Tetra Tech, Inc.
 10306 Eaton Pl., Ste. 340
 Fairfax, VA 22030
 (703) 385-6000; Fax (703) 385-6007

Rick Hoffmann
 EPA/OST (4305)
 401 M Street, SW
 Washington, DC 20460
 (202) 260-0642; Fax (202) 260-9830

Bob Hoke
 SAIC
 411 Hackensack Ave.
 Hackensack, NJ 07601
 (201) 489-5200; Fax (201) 489-1592

Chris Ingersoll
 NBS
 Midwest Science Center
 4200 New Haven Rd.
 Columbia, MO 65201
 (314) 875-5399

Doug Johnson
 EPA Region 4
 345 Courtland Street, NE
 Atlanta, GA 30365
 (404) 347-1740; Fax (404) 347-1797

Ken Klewin
 EPA Region 5 (WS-16J)
 77 W. Jackson Blvd.
 Chicago, IL 60604
 (312) 886-4679; Fax (312) 886-7804

Fred Kopfler
 Gulf of Mexico Program, Bldg. 1103
 Stennis Space Center, MS 39529
 (601) 688-3726; Fax (601) 688-2709

Paul Koska
 EPA Region 6
 1445 Ross Ave.
 Dallas, TX 75115
 (214) 655-8357

Mike Kravitz
 EPA/OST
 401 M Street, SW
 Washington, DC 20460
 (202) 260-8085

Peter Landrum
 Great Lakes ERL
 2205 Commonwealth Blvd.
 Ann Arbor, MI 48105
 (313) 741-2276

Matthew Liebman
 EPA Region 1
 JFK Federal Bldg., WQE
 Boston, MA 02203
 (617) 565-4866; Fax (617) 565-4940
 email: bays@epamail.epa.gov

Ed Long
 NOAA (N/OMA 34)
 7600 Sand Point Way, NE
 Seattle, WA 98115
 (206) 526-6338

Don MacDonald
 MacDonald Environmental Sciences Ltd.
 2376 Yellow Point Rd.
 Ladysmith, BC
 Canada VORZEO
 (604) 722-3631

John Malek
 EPA Region 10
 1200 Sixth Ave., WD-128
 Seattle, WA 98101
 (206) 553-1286; Fax (206) 553-1775

Audrey Massa
 EPA Region 2
 Marine and Wetlands Protection Branch
 26 Federal Plaza
 New York, NY 10278
 (212) 264-8118; Fax (212) 264-4690

Deirdre Murphy
 MD Dept. of Environment
 2500 Broening Hwy.
 Baltimore, MD 21224
 (410) 631-3906; Fax (410) 633-0456

Arthur Newell
 New York DEC
 Division of Marine Resources
 Bldg. 40, SUNY
 Stony Brook, NY 11790-2356
 (516) 444-0430; Fax (516) 444-0434

Tom O'Connor
 NOAA Status and Trends Program
 Bldg. SSMCY
 1305 East West Highway
 Silver Spring, MD 20901
 (301) 713-3028

Robert Paulson WR/2
 Wisconsin DNR
 P.O. Box 7921
 Madison, WI 53707-7921
 (608) 266-7790; Fax (608) 267-2800

Mary Reiley
 EPA/OST (4304)
 401 M Street, SW
 Washington, DC 20460
 (202) 260-9456; Fax (202) 260-1036

John Scott
 SAIC
 165 Dean Knauss Dr.
 Narragansett, RI 02882
 (401) 782-1900; Fax (401) 782-2330

Thomas Seal
 Florida DEP
 Mail Station 46
 3900 Commonwealth Blvd.
 Tallahassee, FL 32399-3000
 (904) 488-0784

Mohsin Siddique
 Water Quality Control Branch
 2100 MLK Jr. Ave., SE
 Ste. 203
 Washington, DC 20020
 (202) 404-1129

Gail Sloane
 Florida DEP
 Mail Station 46
 3900 Commonwealth Blvd.
 Tallahassee, FL 32399-3000
 (904) 488-0784

Sherri Smith
 Environment Canada
 351 Street, Joseph Blvd., 8th Floor
 Hull, Quebec, Canada
 KIAOH3
 (819) 953-3082; Fax (819) 953-0461

Betsy Southerland
 EPA/OST (4305)
 401 M Street, SW
 Washington, DC 20460
 (202) 260-3966

Mark Sprenger
 EPA ERT (MS101)
 2890 Woodbridge Ave.
 Edison, NJ 08837
 (908) 906-6826

Jerry Stober
ESD-Athens
College Station Rd.
Athens, GA 30113
(706) 546-2207; Fax (706) 546-2459

Rick Swartz
EPA ERL-Newport
Hatfield Marine Science Center
Marine Science Drive
Newport, OR 97365
(503) 867-4031

Nelson Thomas
EPA ERL-Duluth
6201 Congdon Blvd.
Duluth, MN 55804
(218) 720-5702

Rachel Friedman-Thomas
Washington Dept. of Ecology
Mail Slot 47703
Olympia, WA 98504-7703
(206) 407-6909; Fax (206) 407-6904

Burnell Vincent
EPA/ORD
401 M Street, SW
Washington, DC 20460
(202) 260-7891; Fax (202) 260-6932

Mark Wildhaber
NBS
Midwest Science Center
4200 New Haven Rd.
Columbia, MO 65201
(314) 876-1847

Craig Wilson
California SWRCB
901 P Street
Sacramento, CA 95814
(916) 657-1108

Drew Zacherle
Tetra Tech, Inc.
10306 Eaton Pl., Ste. 340
Fairfax, VA 22030
(703) 385-6000; Fax (703) 385-6007

Chris Zarba
EPA/OST (4304)
401 M Street, SW
Washington, DC 20460
(202) 260-1326

Xiaochun Zhang, WR/2
Wisconsin DNR
P.O. Box 7921
Madison, WI 53707
(608) 264-8888; Fax (608) 267-2800